

AUGUST, 1927

25 CENTS.

RADIO

(REG. U. S. PATENT OFF.)

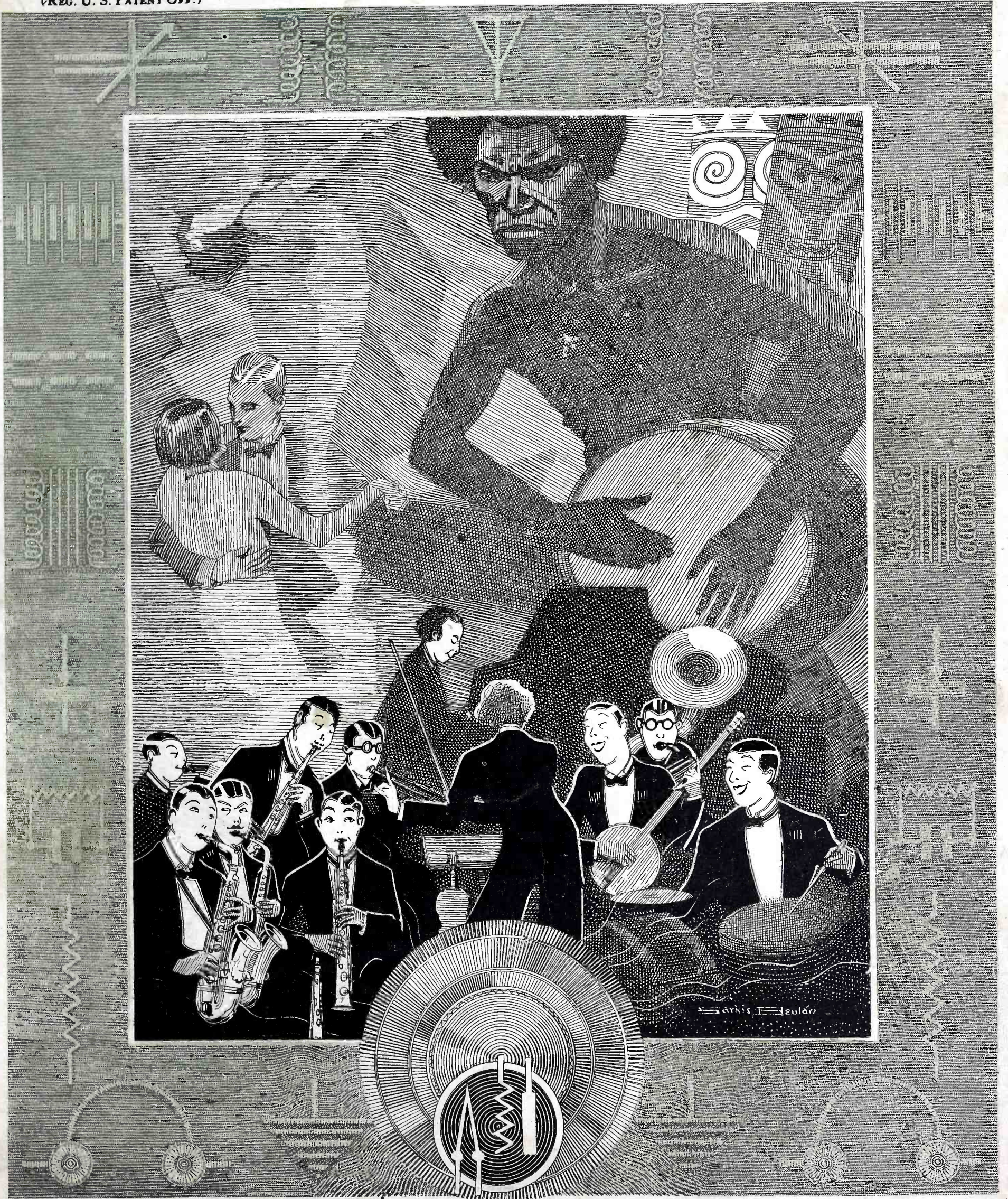

IN THIS ISSUE — The 1928 Infradyne — By E. M. SARGENT
Gerald Best's 5 Watt Power Amplifier

Cunningham RADIO TUBES

Round out the circle of vacation joys—

For real summer enjoyment you cannot do without Radio. To increase that pleasure, Cunningham Radio Tubes are most essential to your set.

No matter where you plan to be,—the mountains, the seashore or the back country—you can depend upon Cunningham Radio Tubes to bring you the world's best music with song, dance and laughter.

Your nearest Radio dealer will tell you the best combination of Cunningham Tubes for your particular set.

E. T. CUNNINGHAM, INC.

New York

Chicago

San Francisco



REMLER

Now You Can Build the

INFRA-DYNE

Easily & Quickly
Safely

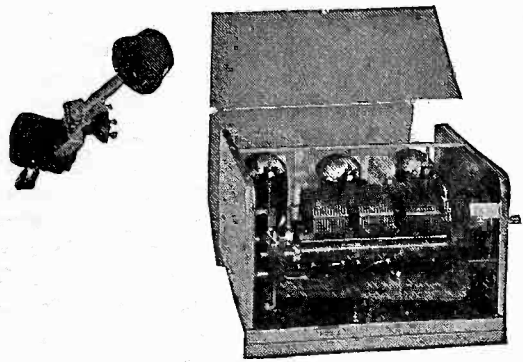

Remler R. F. Amplifier and Antenna Compensator

The No. 710 R. F. Amplifier incorporates two stages of R. F. Amplification and a detector. Entirely enclosed in a sheet copper case which gives complete electro-magnetic shielding. It is designed for single-dial control, either with Remler Drum Dial or the ordinary 360° vernier dial. An Antenna Compensator, supplied with the amplifier, nullifies the de-tuning effect of the antenna, which interferes with efficient operation in the usual single-control R. F. amplifier. A Switch is provided for selective or non-selective tuning.

Included in the Remler No. 710 Amplifier are special solenoid-type, small diameter coils, the Remler 3-in-Line Condenser, Remler No. 50 Sockets, and special resistances.

No. 710.....Price \$55.00

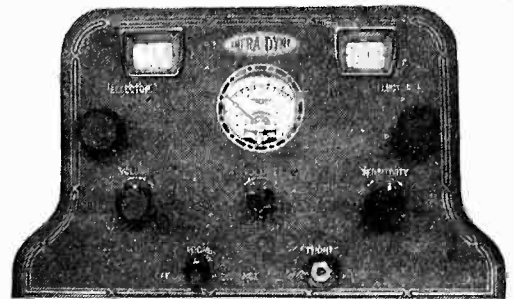

Control Panel of Infradyne Kit

The Remler Infradyne Kit, No. 750, includes the following apparatus: etched copper control panel (illustrated above); pressed steel instrument panel, two No. 110 Remler Drum Dials; one No. 659 Twin-Rotor Condenser; four No. 50 Remler Sockets, three No. 35 Remler Choke Coils; one special Coil; all necessary fixed condensers, rheostats, and fixed resistances; jacks; switches, binding posts; and wire and battery cable in colors to agree with wiring diagram.

The complete instructions include schematic wiring diagram; full-size cable harness template; schematic cable lay-out; diagram of parts and wiring under steel base; plan view of top of steel base.

No. 750—Infradyne Foundation Kit

.....Price \$52.00

USE THE REMLER Radio Frequency Amplifier and Associated Parts



REMLER INFRADYNE CABINET
This copper cabinet, embossed in two-tone brown crystalline enamel, together with a decorated wood base, supplies the highest standards of convenience and appearance for the new Infradyne. Size: 11x26 inches.
No. 760Price \$15.00

Two Hours Work —Then Perfect Reception

The new Remler R. F. Amplifier and Infradyne Foundation Kit are designed to meet the growing demand for complete, tested and trouble-free construction units for the Infradyne Circuit. Now, you can easily build the Infradyne in two hours with the simplest tools. Now, you can be sure of matched parts, scientifically correct design, and proper location of each piece of apparatus. Remler leadership and reputation in the manufacture of quality parts is your guarantee of satisfaction.

Write for special Infradyne folder and also a two-color catalog of Remler parts.

Remler Division of GRAY & DANIELSON MFG. CO.

260 First Street, San Francisco
Eastern Warehouse: Elkhart, Ind.
Chicago New York

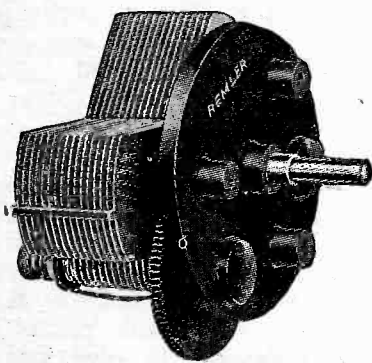

Twin-Rotor Condenser

Rotation of the dial through a full 360° gives greater separation of stations at all wave lengths than is possible with the usual 180° dial. A special adjustment which permits variation of the condenser capacity at zero dial setting allows a still further spreading of the stations in the Straight Line Frequency type.

Both sets of plates rotate. They are driven by Bakelite gears operated by a cam and lever in the Straight Line Frequency type and by a brass pinion in the Straight Line Wave-Length type. This construction results in complete insulation of the dial shaft from the plates, allowing the dial to be grounded and completely eliminating body capacity effects.

Price \$5.00

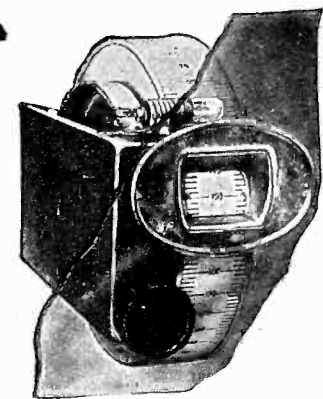

Drum Dial

The Remler Drum Dial gives a full 15 inches of dial space, divided into 200 divisions—2 for each broadcast channel. Calibration strips are rigidly mounted, yet easily removable and renewable. Call letters are readily written in.

Spiral gear drive gives quiet operation and no back-lash.

Socket and 6-volt lamp furnished for illumination. Easily mounted, round drilled hole required for panel plate. The Remler Drum Dial will drive all standard makes of condensers either single or in gangs of two or three condensers.

Mounting template is included in each carton. Calibration strips supplied for either clock-wise or counter clock-wise rotation of dial.

No. 110—Remler Drum

DialPrice \$4.50

Tell them that you saw it in RADIO

Built Like a Battleship, but with *The "Model DX" Infradyne*

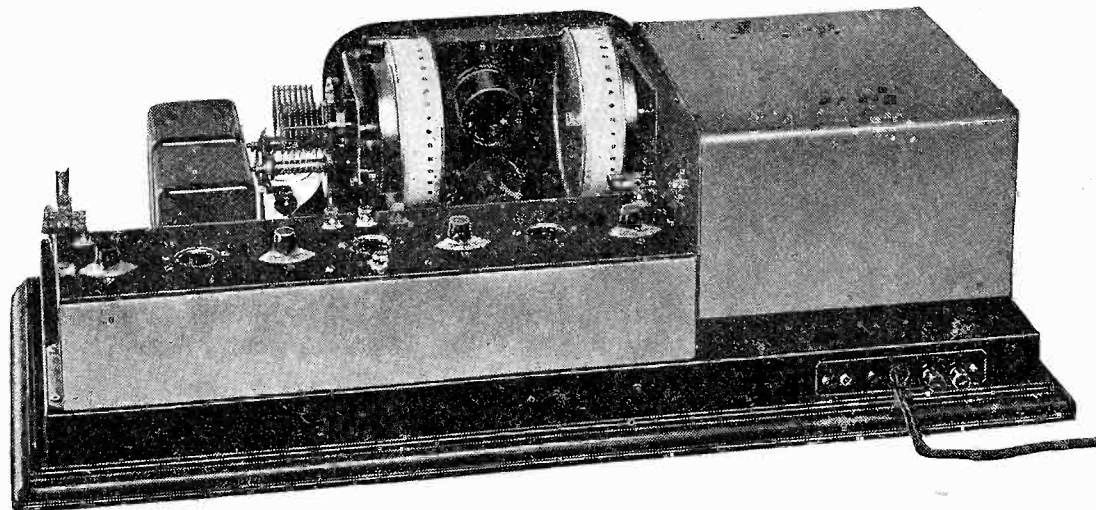

1930 Radio—

The times have changed. Home-built radio for the 1927-1928 season is three jumps ahead of a factory built set. All metal construction—illuminated drum controls—complete shielding—automatic coupling—concealed wiring—new unit construction system—hairsplitting selectivity and the finest tone quality obtainable are yours—NOW. Yet, the price for a real 1930 radio receiver is just about half what you would expect to pay for such construction and performance. The home set builder now buys his set completely assembled—with all

of the essential current supply wiring and audio amplifier wiring in place. He takes a screw driver—hooks on about a dozen short wires and his set is ready for operation. He can change the circuit easily—quickly. He has his choice of a dozen circuits. The illustration shows the new vogue in radio for 1928. The completely assembled Infradyne—the acknowledged leader—the most selective circuit known. It has an enviable reputation for tone quality. Eight thousand Infradyne owners have already been convinced.

EIGHT REASONS WHY THE MODEL "DX" INFRADYNE *Should Be Your Choice*

1. Acknowledged to be the best DX getter.
2. Razor-edged selectivity.
3. Easy to operate—No critical adjustments.
4. The five and ten tube switch is an exclusive Infradyne feature. Economical operation.
5. Tone quality unsurpassed.
6. Built with the strength of a battleship and the precision of a chronometer.
7. Beautiful in appearance. Will be in style for years.
8. A set that you will be proud to own.

the Precision of a Chronometer Immediate Deliveries Now!

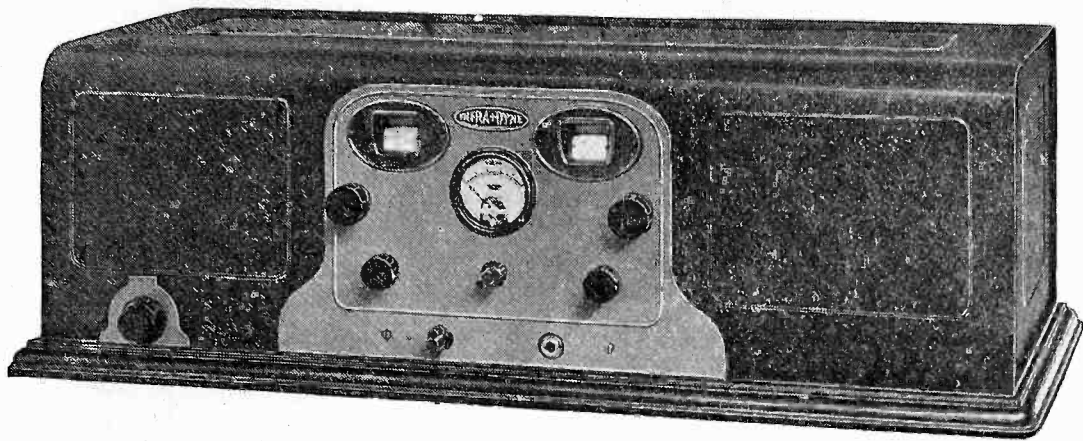

Copper Cabinet—

The cabinet problem solved. The 1928 Infradyne comes to you with a heavy copper cabinet, beautifully embossed and finished in baked crystalline of a neutral shade. The control panel is of bronze. A complete table model, with hand finished hardwood base. Can be easily inserted as a complete unit in a console table, highboy or writing desk. The entire receiver measures only 26 in. in length, a standard size adopted by radio cabinet and console manufacturers. On the control panel you see illustrated

the two tuning controls, switch for 5 or 10 tube operation, "on-off" switch, sensitivity and volume control and plug for headphone operation when desired. Loud speaker plugs into the rear of the set. With its copper cabinet this receiver makes a beautiful table model. Here you save from \$20.00 to \$30.00 for a cabinet. The added shielding afforded by means of the copper cabinet is of vital importance in present-day broadcast congestion.

\$179.50

WITH SHIELDED
CABINET

F. O. B. OAKLAND, CALIFORNIA

This price includes the completely assembled receiver with all current supply wiring in place. 90 per cent of the wiring is done for you in our laboratory. Two SM 220 Audios are included in the price. These transformers and the audio circuit are wired before the assembly is shipped to you. Deduct \$7.00 if no wiring of any kind is wanted.

See It Displayed by

Pioneer Radio Company
1200 Franklin Street
Oakland, California

Remloc Radio Company
206 Pacific Building
Fourth and Market Streets
San Francisco, Cal.

Free circulars on request.

Use This Coupon — NOW!

RADIO CONSTRUCTORS CORP.
357 Twelfth Street
Oakland, Calif.

Gentlemen—

I am interested in the "Model DX" Infradyne. Please send me further information about it.

Name.....

Address.....

City and State.....

NOTE—I am (not) a radio dealer.

RADIO CONSTRUCTORS CORPORATION
357 TWELFTH STREET **OAKLAND, CALIF.**

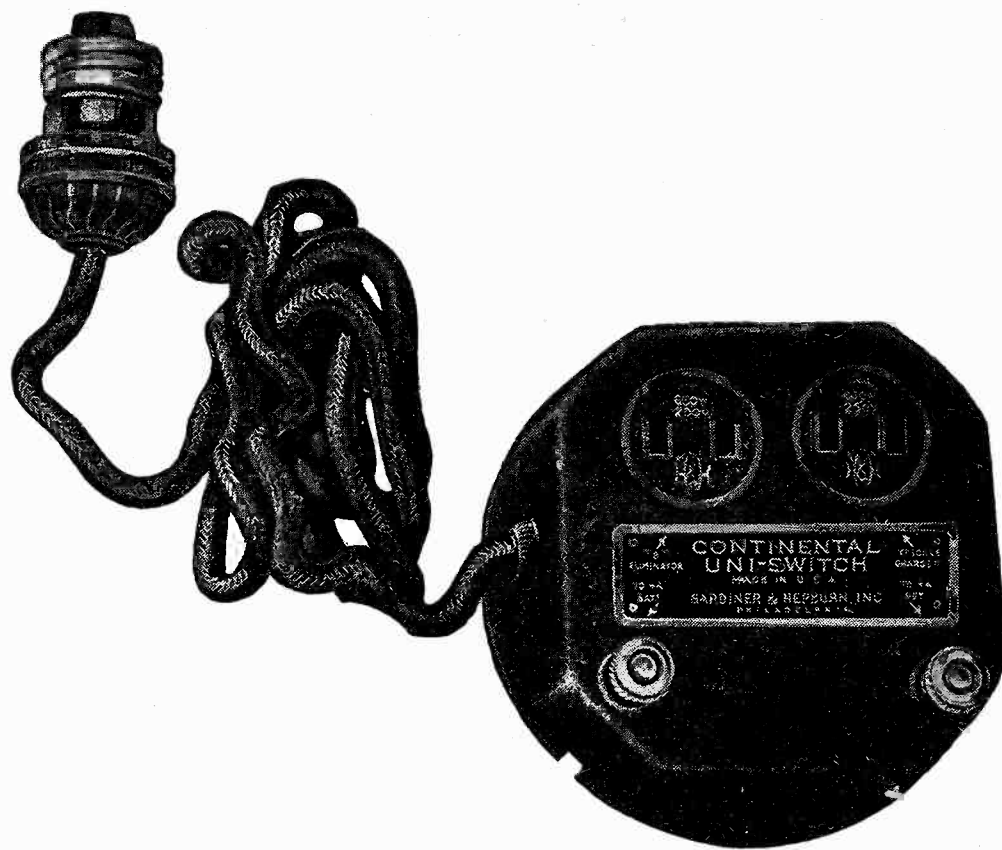

CONTINENTAL UNI-SWITCH

An Automatic Double Throw Switch that entirely does away with all switches connected with your radio receiver except the off and on switch, and transforms your receiver into a complete electric power unit when used in conjunction with six volt Storage Battery Trickle Charger and B-Eliminator.

When the receiver of three tubes or more is turned on, UNI-SWITCH automatically disconnects the Trickle Charger and puts the B-Eliminator in operation. By turning off the receiver, UNI-SWITCH reverses the operation by turning on the Trickle Charger to charge the "A" Battery and disconnects the B-Eliminator.

UNI-SWITCH can be used with any radio receiver employing three or more tubes of the six volt type and can be used with Trickle Charger and Storage Battery alone or with B-Eliminator alone.

List Price, \$3.00

MANUFACTURED AND GUARANTEED BY

GARDINER & HEPBURN, Inc.

611 WIDENER BUILDING, PHILADELPHIA
SAN FRANCISCO—171 SECOND ST.

Factory:

2100 WASHINGTON AVENUE

Makers of the Famous CONTINENTAL Condensers

RADIO

WITH WHICH IS INCORPORATED "RADIO JOURNAL"

VOLUME IX

AUGUST, 1927

No. 8

Radiatorial Comment

The language of radio is in need of revision. Its heavy terms, which it has inherited from heavy electrical engineering, should be stepped down for more popular usage. Any new art is always dependent for a time upon the nomenclature of the old art from which it is an outgrowth. But as it grows out of its swaddling clothes and learns the meaning of its existence it begins to talk in a new language of its own.

The new words are usually short and vivid,—slang if you will. Many of the old words are retained and needed for precise expression. But the public balks at jaw-breaking words and in lieu of better substitute adopts the initial letters. Thus "r. f." for radio frequency amplification, "a. f." for audio frequency amplification, "m. g." for motor-generator, or "c. w." for continuous wave are in current use. Interference due to radiation from an oscillating vacuum tube is now almost universally known as blooping.

Just now we need relief from "heterodyning," not only in its actual physical effect but also in the mental reaction of this long word upon the hearer. Since the Federal Radio Commission has taken steps to minimize its physical occurrence a radio nomenclature commission ought to substitute some less awkward expression to designate this cause of some of the annoying howls and squeals in a radio set.

Another radio word that should be thrown in the discard is wavelength. The length of a radio wave, if such exists, is not measured directly, but is calculated by dividing the speed of light by the frequency of oscillation. The fundamental and controllable factor is the frequency. Then why not use it?

Broadcast stations are assigned their position in the radio spectrum on the basis of frequency. This is ordinarily expressed in thousands of cycles, or kilocycles, per second. The numbers are even, with a regular 10 kilocycle separation. When expressed as wavelengths they are uneven fractions, with an irregular separation. Furthermore the cumbersome conversion from kilocycles into wavelengths gives a false impression as to the crowding of the stations operating at the higher frequencies. The frequency designation is as much of an improvement over the wavelength as is the use of dollars and cents superior to the use of pounds, shillings and pence.

The easiest way to bring about this much-to-be-desired change is for those who know radio to invariably use the kilocycle designation. If the experts continue to use the k. c.

rating and ignore the wavelengths the public will adopt it along with the Mike as another Irishman in radio. It is easier to locate and think of a station between 550 and 1500 k. c. than as between 545.1 and 199.9 meters. This process is being greatly aided by those progressive manufacturers who mark approximate dial settings in kilocycles.

New usages sometimes call for new coined words. By these we refer not to the hybrid names without pride of ancestry or hope of posterity that have been adopted to distinguish various radio receivers, but to new technical words which are necessary to more clearly express scientific relationships. An example of the latter is the "transducer" which the I. R. E. Committee on Standardization has proposed to define any device which is actuated by power from one system and supplies power to another system when these systems may be either electrical, mechanical or acoustic.

Thus a telephone receiver is a transducer actuated by power from an electrical system and supplying power to an acoustic system. A microphone is a transducer actuated by power in an acoustic system and delivering power to an electric system. A phonograph pick-up is a transducer electro-mechanically actuated by a phonograph record and supplying power to an electric system. In each case the waveform in the initiating system corresponds to the waveform in the reproducing system.

This new word supplies a common denominator for several apparently dissimilar devices. By using a group of associated fundamental units it is possible to compare the operating efficiencies and thus arrive at standards of performance.

This is typical of the work that the Institute of Radio Engineers has done during the past fifteen years in advancing the art and science of radio communication. Through the presentation, publication and discussion of original papers it has greatly aided in the exchange of radio information of a technical and engineering nature. There is hardly an American associated with the technical advancement of radio who is not a member of this organization. Many noted radio engineers and scientists in other countries are also actively identified with it.

It is to this body that the industry looks for much of the progress in standardizing radio nomenclature. And while it can hardly be expected to provide the popular words which will clear broadcasting of its many cumbersome expressions, it can and is performing a wonderful service in defining the terms used by radio engineers.

Short Wave Communication in the Navy

An Authoritative Account of the Development of Short Wave Transmission by the Amateurs and of its Adoption by the U. S. Navy and Army

A. L. Young, Associate Radio Engineer, Navy Department

FEW of us realize the important bearing of present day broadcasting and other radio activities upon the phenomenal distances being covered by short wave transmissions. The radio act of 1912 allocated wavelengths of not over 200 meters for amateur use and the wavelengths above 200 meters for commercial and military purposes. It was thought at the time that since amateurs would cover short distances the short wavelengths would suffice and that the longer wavelengths, which it was thought would cover longer distances, would be more suitable to commercial and military organizations. Little did the framers of the law know that wavelengths below 200 meters would receive the attention they are receiving today.

The majority of the amateurs, prior to the World War, used spark transmitters, which when restricted to $\frac{1}{2}$ k. w. as the law specified, seldom covered more than a hundred miles. The World War wrought many changes, among which were great strides in the improvement of the vacuum tube. The amateurs were not slow in adopting this wonderful device and it was not long before they were in possession of vacuum tube transmitters of their own manufacture. Spark transmitters were soon discarded.

Amateur built tube transmitters working on the short waves were able to cover phenomenal distances with comparatively small power. Amateurs not only established a network of stations over the United States but were successful in carrying on communication.

(Continued on page 38)

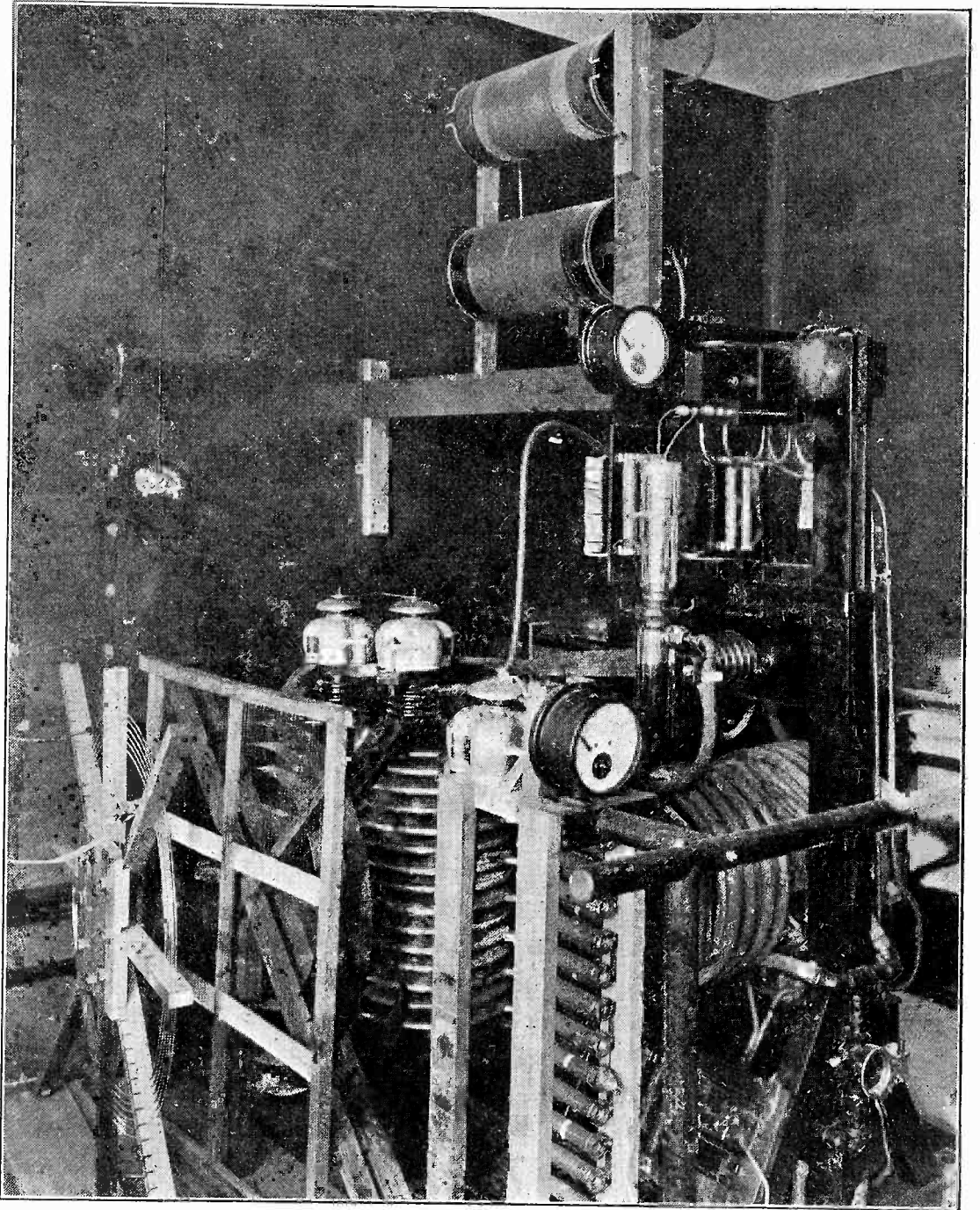

Type of Short-Wave Transmitter Used by R. C. A. Between Manila and San Francisco on 15 Meter (Daylight) and 30 Meter (Night) Service. This Equipment Uses Two Water-Cooled 20 K. W. Tubes and A Single 75-ft. Vertical Antenna

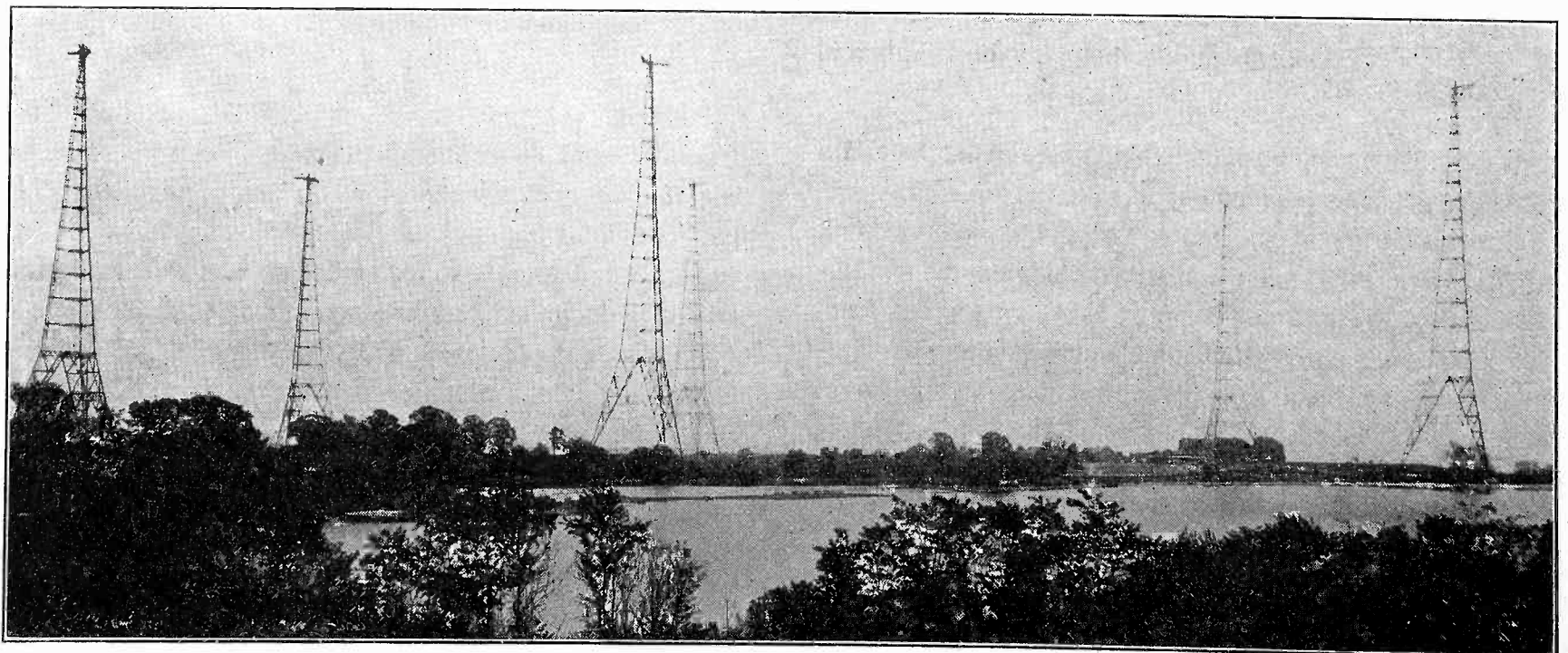

Elaborate Long-Wave Antenna System at Annapolis Which Can Be Replaced by 75 ft. Single Wire for Short-Wave Transmitter

Air Craft Radio Navigation

A Description of The U. S. Signal Corps Radio Beacon As First Employed in the Hawaiian Flight

By Captain Edward F. French

OF the various aids to safety in flying one of the most promising is the radio beacon developed by Capt. Paul S. Edwards and his staff of Signal Corps engineers at the McCook Field, Dayton, Ohio. This system was given its first great practical application during the successful flight of Lieutenants Maitland and Hegenberger from San Francisco to Honolulu late in June.

For this project the Signal Corps installed two radio beacons, one at the Presidio of San Francisco and the other at Paia on the island of Maui, which is south and east of the island of Oahu where Honolulu is located. By means of a 2 kw. transmitter and two triangular loops supported on a 90 ft. pole

of two coupling coils arranged so that they can be swung through 360 degrees for adjustment to any course.

The receiving set on the Fokker monoplane used in the Hawaiian flight was an eight-tube superheterodyne with an antenna consisting of a single wire weighted with a 3 lb. bob and trailing beneath the plane.

The transmitter consists of a 500 cycle vacuum tube transmitter which emits continuous waves of the completely modulated type. There are two General Electric Type UV 851 1 kw. vacuum tubes, one connected on each side of the cycle, which gives the familiar "self rectified" system. These tubes are nominally rated at 1000 watts antenna input and

when so operated will function with very great efficiency, giving about 2000 watts radio frequency energy available in the antenna system. Power is supplied from the Post power house to operate one motor-generator to supply plate current and another smaller machine to provide for filament current. A complete switchboard is provided to control the entire transmitter. A small gas engine is ready for emergency service in case of power failure.

Keying, or signalling is arranged in the transformer primary circuit, and the designating letters are repeated mechanically by suitably spaced rotating wheel contactors, such as are in use with radio beacons generally for the purpose of giving designating letters. The transmitter is coupled inductively to the antenna circuit, through proper goni-control switches, and these are provided with an interlocking mechanism so the proper signal can only be sent when the transmitter is connected to the designated aerial. The oscillating circuit of the closed circuit is of conventional type. Signals were transmitted on a wavelength of 1030 meters (290 k. c.).

Satisfactory results were obtained during this first flight, both beacons functioning perfectly to indicate the course. The Maui beacon was heard 800 miles from Honolulu. This test is believed to have given conclusive proof of the dependence that can be put upon this new aid to aerial navigation.

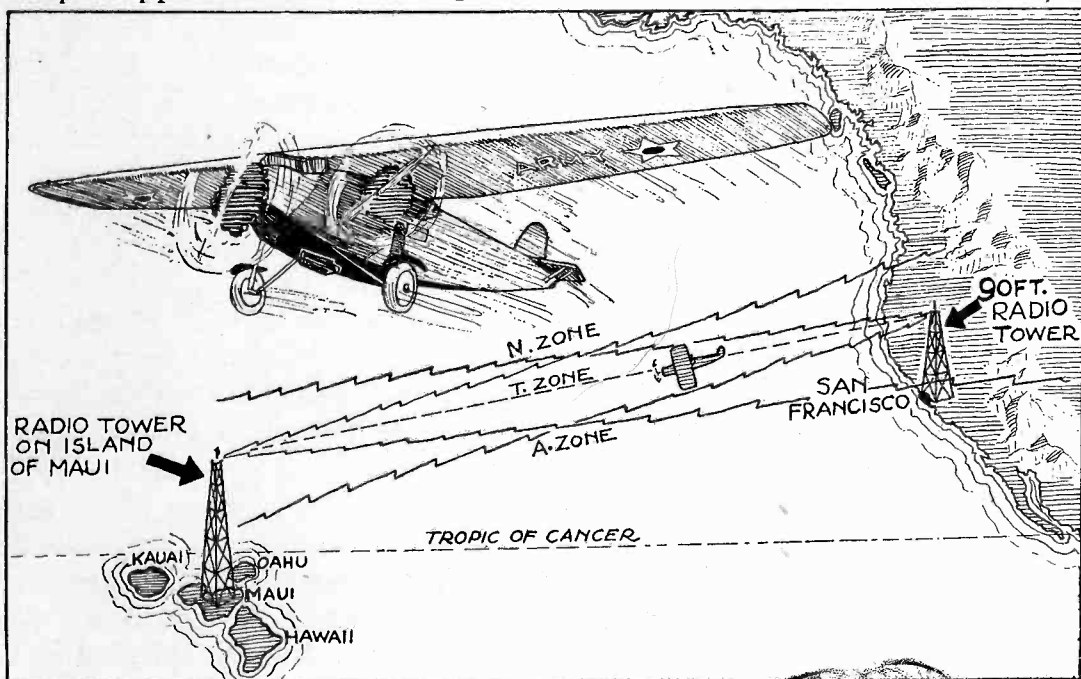

Sketch Showing Method of Radio Plane Guidance—by Ted Rockwell

each station transmitted the letter *N* (— —) from the north loop and the letter *A* (— —) from the south loop. Consequently *N* is heard north of the course and *A* south of the course. When the plane is directly on the true course the two signals merge so that only *T* (—) is heard.

Consequently when all is working well the pilot or navigator have merely to keep the plane on such a course that they hear only the *T*. If they hear the *N* they steer to the south till only the *T* is heard. If they hear the *A* they likewise move to the north.

The emitted signals are sharply directional, the audible beam having a field that increases $\frac{1}{4}$ mile in width in each 200 miles. The signals are transmitted by automatic keying, alternately giving the correct signal to each loop.

The base of the aerial system is 300 ft. long. The loops are coupled to the transmitter by a goniometer consisting



Beacon Equipment at San Francisco Presidio

A Visual Radio Compass

By Ensign Archibald Maclean

U. S. Coast Guard

One of the chief objections to the use of the usual type of radio compass equipped with headphones is the possibility of confusion as to the relative strength of signals heard. In this connection Lieutenant Fanning of the Navy has planned a compass which will give a visual indication of the bearing as recorded on the graduated scale of a double-reading milliammeter.

As shown in the accompanying sketch the idea is to use two loops, each connected to a separate receiving system.

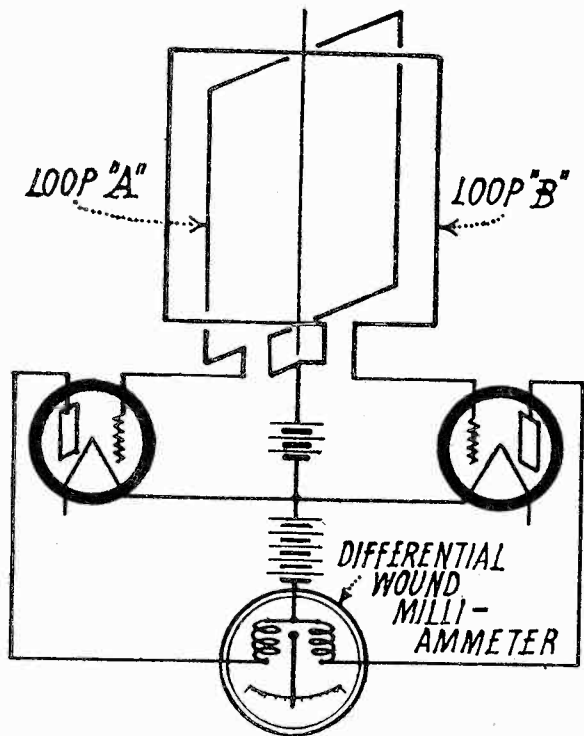

Sketch of Visual Radio Compass

The output of each receiver is fed into opposed windings in the meter. When the two signals are equal the meter will give a zero reading and the exact bearing will be known. When the cross wire is off the bearing, the energy will be unequal and the meter will show a deflection either to the right or left.

In operation, the pedestal is manipulated until the needle stops wavering on the scale and remains at zero. This will be the true bearing on the azimuth circle where cut by the cross wire and eliminates the chances for inaccuracy. Either maximum or minimum signals can be used and a reversed bearing may be taken for extreme accuracy.

The present system locates a bearing by means of audible signals and the accuracy of the bearing is dependent upon the judgment of the operator as much as on the equipment itself. This is not, in my opinion, a desirable condition and if the audible feature can be removed and an accurate visual substitution made that will work, I believe that some of the objectionable features will have been eliminated from the radio compass for the simple reason that no

one likes to wear a pair of ear phones and manipulate a heavy pedestal and at the same time try to guess which are the weakest signals that are coming over the receiver. The Federal Telegraph Company, I believe, has developed a visual compass using a light system which flashes off and on as the ship yaws from the desired bearing.

My intention in writing this article is to broadcast the idea to all those interested in radio with the thought of inviting discussion as to its practicability and also with the hope that someone will experiment and prove it. No facilities are available at my present station or I would, of course, try it myself. There may be some other factors to be taken into consideration for its use on a large vessel but for installation on a small patrol boat or on an aeroplane no difficulties are expected that will not be comparatively simple of elimination. If the double loop, pedestal and dummy compass or azimuth circle seem excessive for installation on a small vessel or aeroplane a much simpler method can be used, utilizing the ship's compass, as follows: A fixed loop can be mounted at the most advantageous point on the center line of the vessel and the indicating meter placed in the pilot house near the binnacle, or in the case of aircraft, on the dash directly in front of the pilot. Bearing signals are then asked for by radio, the radio compass switch turned on and the ship swung in a circle. The needle will waver until the ship is directly headed towards the point from which the signals are being sent. Then the signals in the opposed windings in the milli-ammeter being equal, the needle will stop and remain at zero until the ship's head again falls off the proper bearing. The ship can be kept on the course indicated by the radio signal or the course can be shifted to any other wanted if the location of the point transmitting the signals is known.

In the case of an aeroplane returning to a vessel at sea, the parent vessel's location need not be known as the plane can be kept on the course from time to time by radio signals sent out from the parent ship. Vice versa, in the case of a plane lost at sea, its position need not be known, with a low power, high frequency radio set kept going at intervals the searching vessels utilizing the visual radio compass could pick up its signals in jig time and immensely speed up the problem of rescue work that confronts us at present when a trans-Atlantic flyer is lost.

If this visual type radio compass proves practical, for a trans-oceanic flight all that would be necessary is for the plane leaving New York or San Francisco to get a bearing on the radio station in Paris or Honolulu and sail directly towards that bearing. The pilot would receive his signals at intervals, keep his eye on the needle on the dash and correct his course whenever the wavering of the needle would indicate that his nose was not headed for the correct bearing. The course would be more accurate than a straight compass course and would have the advantage of being a great circle course with the entire elimination of any navigation work by the pilots.

It is quite likely this idea has been experimented with before but the knowledge of it has not been disseminated to the radio world and it is quite sure from present indications that air navigation will never become general, safe or even practical until some such method of navigating by radio compass is perfected. A pilot has enough to think about and contend with without being bothered with the details of plotting his courses and unless he does so, at present, after he has flown a thousand miles or so, he has no idea where he is.

It is quite likely some ham will develop the radio compass where it will be possible to utilize it in trans-oceanic air travel and when that is done, we can almost consider the consistent passage of the oceans an accomplished fact.

OFFICIAL LIST OF PARTS FOR BROWNING-DRAKE A.C.-OPERATED RECEIVER DESCRIBED IN JULY RADIO

- 1 Browning-Drake Kit, instructions contained, (Browning-Drake Corp.)
- 1 Foundation unit consisting of Westinghouse Micarta panels drilled and engraved with sockets, resistor clips, soldering lugs, machine screws, nuts, bolts and wire, (Browning-Drake Corp.)
- 1 National Impedaformer (1st stage).
- 1 National Impedaformer (3rd stage only).
- 1 Tobe Condenser, special Browning-Drake type.
- 3 .001 Tinytobe fixed condensers.
- 1 .00007 Tinytobe fixed condenser.
- 1 Yaxley Filament switch No. 10 BD.
- 1 Yaxley 30 ohm rheostat No. 130K-BD (gold filled arrow).
- 8 Eby binding posts (Ant., Gnd., A+, [A-B-], B+, Det., B+ Amp., C+, C-).
- 1 Precise Midget .0001 variable condenser.
- 1 Browning-Drake 33 ohm resistance cartridge.
- 3 Resistances (one .1 meg. one 1/4 meg., one 8. meg.) Electrad.
- 1 Browning-Drake balancing or neutralizing device.
- 2 Yaxley pup jacks (if tone filter is not used).
- 1 National tone filter (optional).
- 1 Tinytobe .006 condenser.

The 1928 Infradyne Receiver

Assembly Details for The New Model of This Popular Ten-Tube Circuit

By E. M. Sargent

ASSEMBLY of the 1928 infradyne whose salient features were described in July RADIO, has been so greatly simplified by the kit manufacturers, that a comparative novice can put it together ready for operation in a few hours.

Examination of the picture in Fig. 1 and the diagram in Fig. 2 shows it to consist essentially of a shielded two-stage tuned r. f. amplifier unit at the left, a three-stage high frequency Infradyne amplifier unit in the rear, two

drum dials operated by tuning knobs on the front panel, an oscillator tube, a detector tube, and two a. f. tubes with their associated transformers.

Most of these units are mounted on a pressed steel base with the wiring concealed beneath. The control knobs and voltmeter are mounted on a small steel panel in the front and center of set and the complete equipment is housed in an enamelled sheet copper cabinet supported on a decorative wooden base. By means of the filament

switch the set is instantly converted from a 10-tube infradyne for long distance work to a five tube tuned r. f. receiver for local reception.

The two stage tuned r. f. amplifier unit covered by the copper shield at the left in these pictures contains a Remler type 633 three-in line condenser, three coils and three tube sockets, these constituting two stages of r. f. amplification and a first detector. The triple condenser is operated by the left hand drum dial being associated with

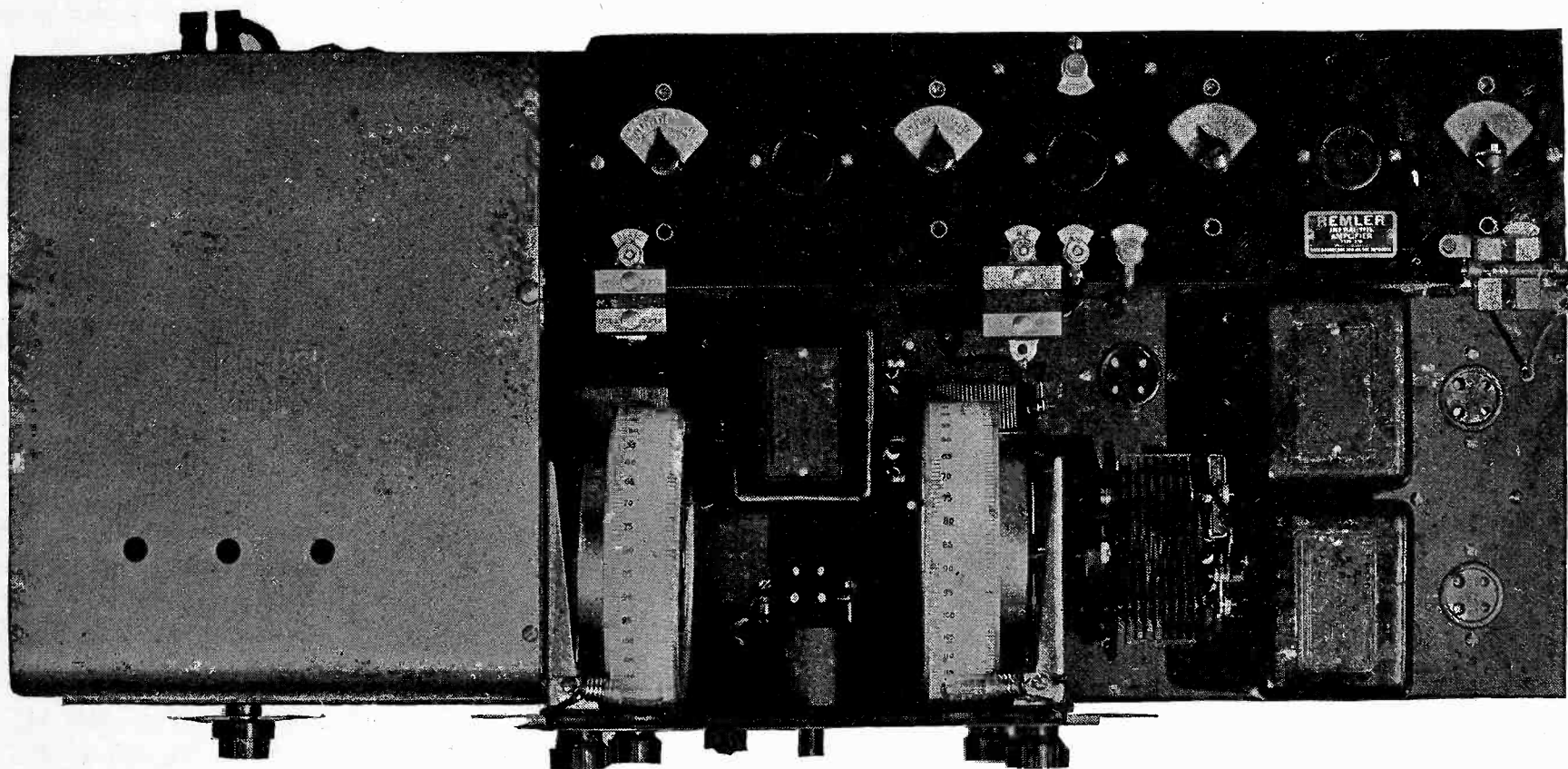

Fig. 1. Complete Infradyne Receiver with Cabinet Removed.

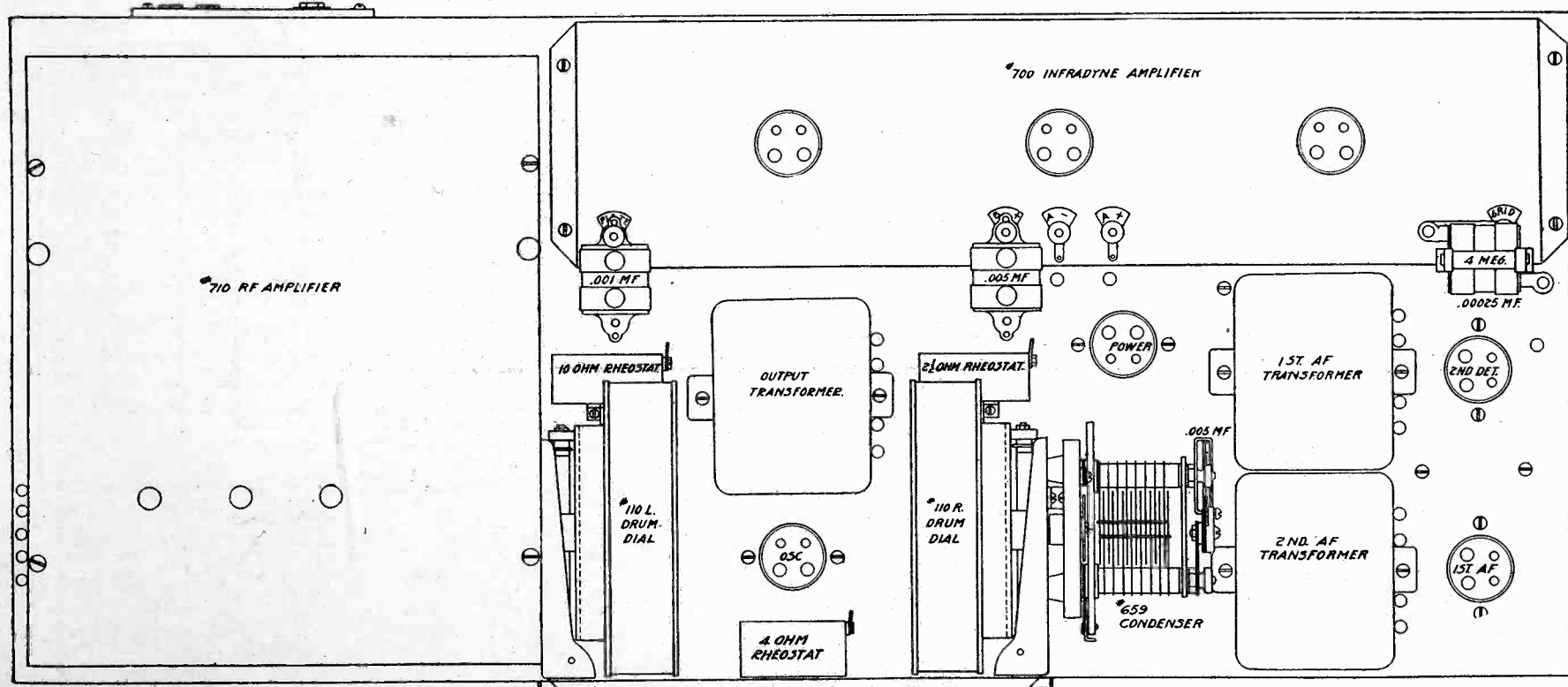

Fig. 2. General Arrangement of Parts

three small compensating condensers with which the set is balanced when first put into service.

The solenoid coils are wound so as to have a small external field, the secondaries being in two halves connected so as to help maintain stability throughout the entire wavelength range. The primaries are automatically rotated inside the secondaries by means of the condenser shaft.

The circuit diagram of Fig. 3 shows the remaining connections and circuit constants. These may also be identified in the accompanying list of parts.

Actual assembly is started by mounting the various small parts on the bottom of the steel base as shown in Fig. 4 and 5. The base is drilled to receive all mounting screws and wires which are to project through it.

The four Remler No. 50 sockets are first mounted with their terminals placed as shown in Fig. 4. The two special bakelite terminal blocks are next put in place and then the two Remler No. 35 choke coils (Nos. 1 and 2.)

Choke No. 3, at the upper right of Fig. 3 together with its associated .00025 mfd. condenser is mounted by putting the machine screw through its base from the top side, placing one condenser lug over the screw, putting on the spacers, then the choke coil, and fastening the assembly down with the nut.

The Electrad Type P .005 mfd. condenser with bent lugs is fastened in place with screw and nut in a position about halfway between the front and back of the base and directly opposite the hole in the front edge of the base for the switch. Now solder the three

fixed resistors to the proper socket terminals. The next step is to fasten the 4 in. x 3/4 in x 1/8 in bakelite terminal strip in place using two 1/4 in. x 6-32 screws, one at each end. On this strip mount the "Antenna" and "Ground" binding posts and the Frost No. 953 jack. The jack is mounted so that the 1 1/4 inch fibre insulating washer is held between the steel base and the body of the jack.

Before preparing the cable harness, make ready and connect up the battery cable. Cut 4 in. of the outside covering from one end of the cable and 15 in. from the other end; wrap binding cord around the ends of the covering to keep it from fraying. Pass that end of the cable having the 4 in. leads through the bakelite terminal strip from the outside. Cut the individual cable wires the correct length for connection to the terminal blocks in accordance with the color code indicated in Fig. 4. The general method of connecting up the battery cable is shown clearly in Fig. 5. Wrap tape around the battery cable where it passes through the clip holding it to the base and fasten the clip to the base. Scrape about 1/2 in. of the insulation from the terminal block end of each of the cable wires and solder the wires to the terminal blocks.

The cable harness is built up by means of a template which is supplied with the kit and placed on a flat board into which nails are driven at designated points. When finished in accordance with the directions there given it is laid out on another template so as to indicate the position of the various leads. As these aids are necessary only

for the extreme novice, their details are omitted here. The soldered connection for the units on the underside of the steel base are well shown in the pictures herewith including the picture of the cable layout in Fig. 6.

The base is then turned over with the control panel side to the front so that the 10 and 2 1/2 ohm rheostats constituting the "Volume" and "Sensitivity" controls can be mounted on brackets as shown in Fig. 7.

The 10 ohm rheostat is at the left and the 2 1/2 ohm rheostat at the right. The leads to be connected to the 10 ohm rheostat extend up through the steel base; of these, the double lead should be connected to that side of the rheostat which is common electrically with the steel base, or in other words, to that side of the rheostat which is grounded. Soldered connections should be made to lugs fastened securely under the rheostat terminal nuts.

The two Silver-Marshall audio transformers, the Silver-Marshall output transformer and the No. 700 Infradyne amplifier are now fastened in place with screws and nuts. Fasten to the Silver-Marshall transformer terminals the leads projecting up through the steel base. The colors of these leads and the terminals to which they are to be connected are clearly indicated in the diagrams.

The Electrad Type P .001 mfd. condenser is placed on the Infradyne Amplifier "Plate" binding post and the .00025 mfd. condenser on the Infradyne Amplifier "Grid" binding post, using for the latter condenser the special bracket supplied. Put soldering lugs

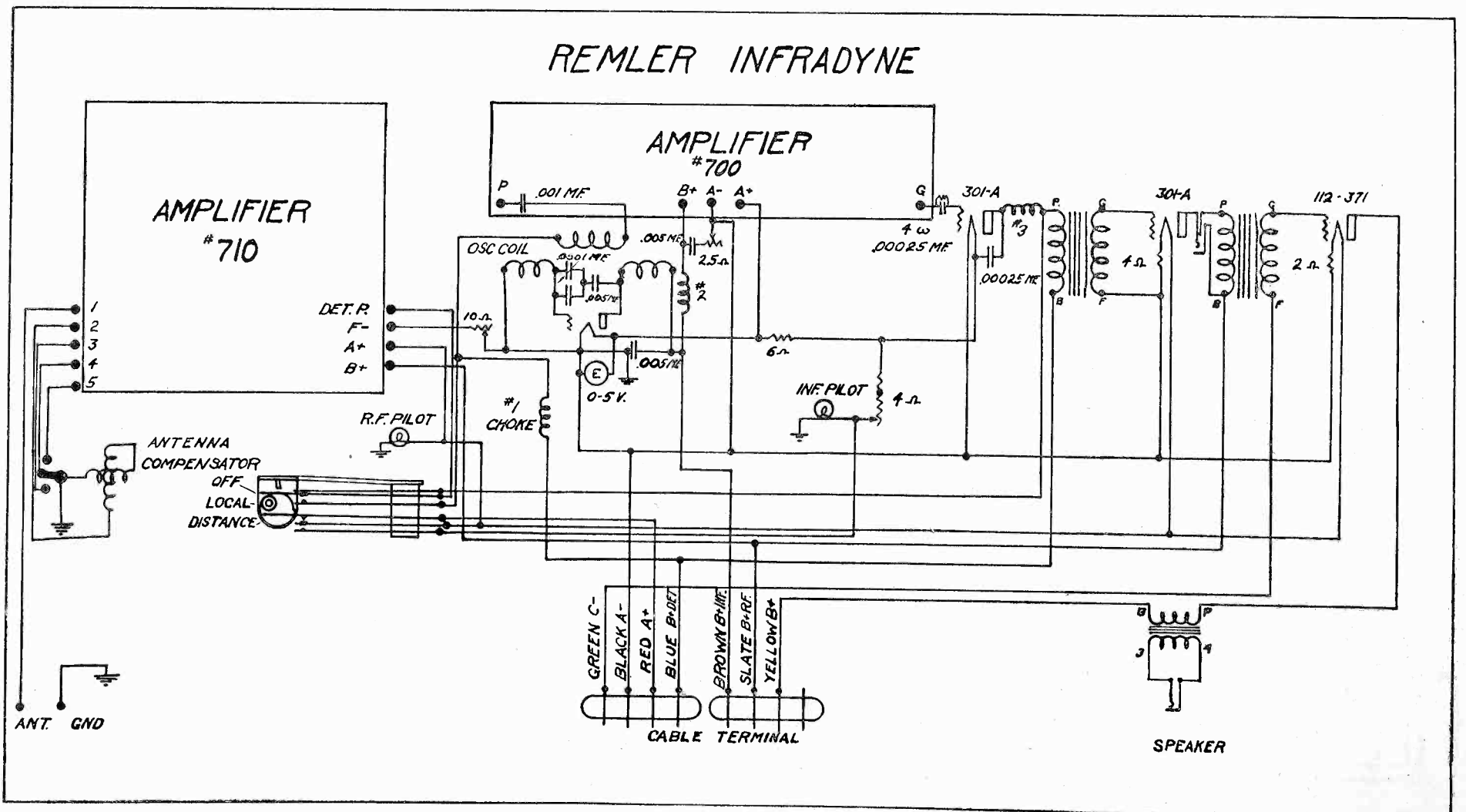

Fig. 3. Infradyne Schematic Circuit Diagram

the single and double yellow leads above mentioned the double yellow lead will be connected to the rheostat.

The right-hand drum dial and oscillator condenser assembly will now be put in place. Fasten the special brace to the right-hand drum dial plate and mount the dial plate on the steel instrument panel with 1/4 in. screws. Fasten the special brace to the pressed steel base. Fasten the special condenser and the .005 mfd. fixed condenser to the Remler Type 659 condenser and mount the assembly on the drum dial plate. One terminal of the Type 659 tuning condenser is connected to one terminal of the special condenser and to one terminal of the .005 mfd. condenser. The other terminal of the special condenser is connected to the remaining terminal of the tuning condenser and the free terminal of the .005 mfd. fixed condenser is connected to the brown wire of the twisted pair of wires extending up through the base. The remaining wire of the twisted pair will be connected to the terminal of the Type 659 Condenser to which we have previously connected only one terminal of the special condenser. The twisted pair referred to is shown in Fig. 4.

Next mount the voltmeter on the steel instrument panel and connect to its terminals the leads extending up through the base. Now mount the lamp brackets on the drum dial plates and connect them into the circuit. The leads to the pilot lamps project up

through the steel base. Make connections to the lugs next to the lamp socket shells.

The bronze control panel can now be placed in position. It will be held in place by the threaded bushings which are screwed into the drum dial plates and through which the dial shafts extend. Insert the rheostat extension shafts with the lock-nuts over them between the panel and the rheostats and attach the threaded bushings to the control panel by means of the lock-nuts. Washers are furnished for use next to the panel. Fasten the extension shafts to the rheostats.

The Frost No. 954 Jack, insulating bushing, threaded bushing and washer are then connected. We can now turn the pressed steel base up on end and fasten the antenna compensator in place as shown in Figs. 4 and 5.

Comparatively little remains to be done. Those wires indicated in Fig. 4 and not yet installed must be soldered in position, thus completing the wiring. The bakelite control knobs are now mounted on the control panels. Two of the knobs are small in size; they are for the switch and voltage controls. The last step before testing will be to put the 4 megohm grid leak in place in the clips on the .00025 mfd. condenser supported on the Infradyne Amplifier "Grid" binding post.

TESTING

Remove about 1 1/2 in. of the insulation from each of the wires at the out-

side end of the battery cable. Connect a lamp and battery in series and, with the switch in the "OFF" position, test between the various wires of the cable for short-circuits. The "Ground" and A- are connected to the steel frame. Connect C+ and B- to A- or A+. The color code for the cable and terminal wires follows:

A-	Black
A+	Red
B+Detector	Blue
B+Intermediate	Brown
B+R.F. and 1st A.F.	Slate
B+Power	Yellow
C-	Green

We are now ready to install the tubes and to put the set into operation. Remove the top from the No. 710 Radio Frequency Amplifier and insert three CX 301A or UX 201A tubes. Now install CX 299 or UX 199 tubes in the Infradyne Amplifier sockets and in the socket located in the steel base immediately below and back of the voltmeter. Put CX 301A or UX 201A tubes in the sockets at the extreme right-hand end of the base. Put a CX 112 or UX 112 tube (CX 371 or UX 171 can be used) into the socket located between the oscillator tuning condenser and the Infradyne Amplifier.

Connect the red and black wires in the battery cable to the positive and negative terminals respectively of a 6-volt storage battery. Turn the switch to the "LOCAL" position. All tubes except the CX 299's and the CX 301A

(Continued on page 40)

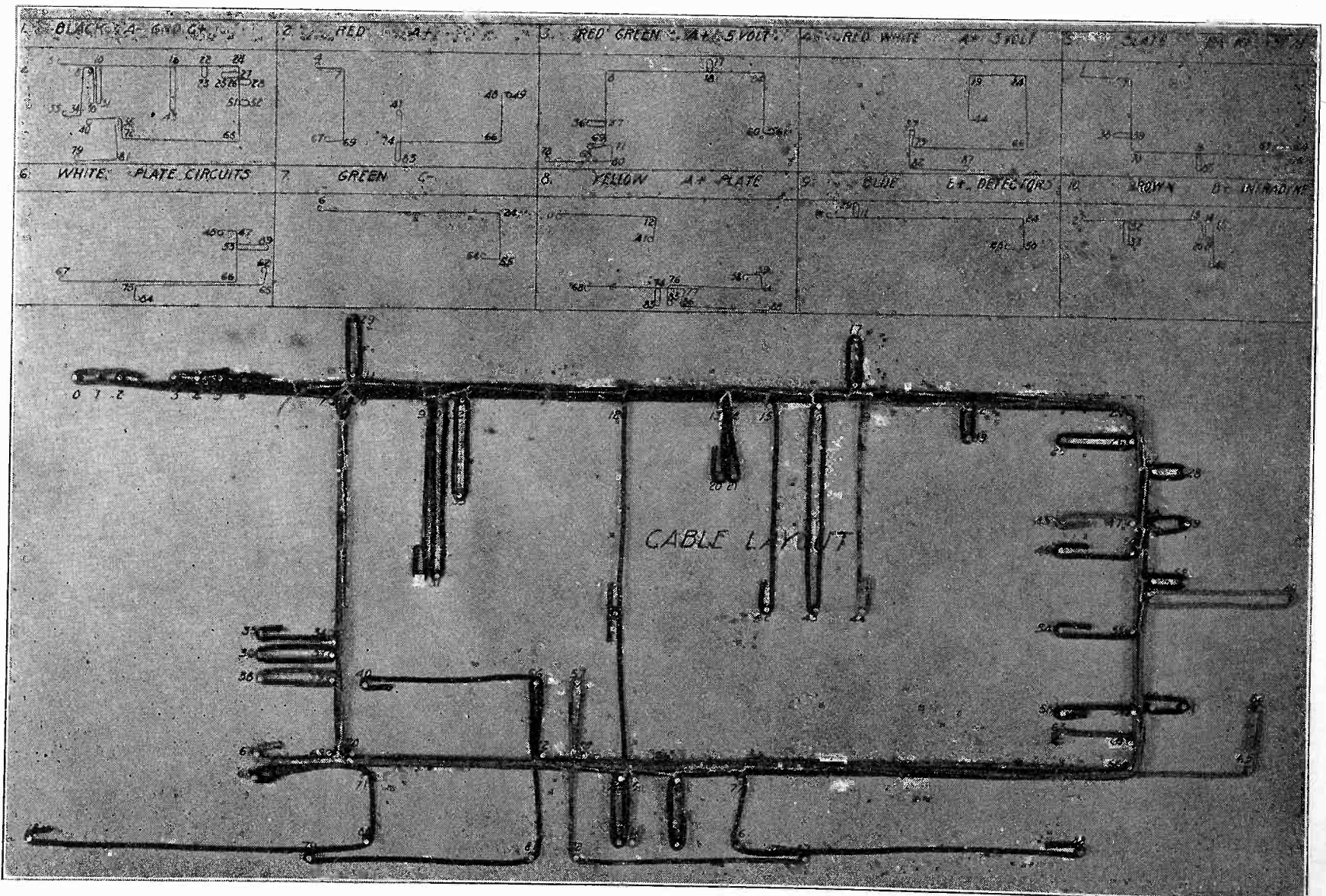

Fig. 6. Cable Layout

A High Quality Power Amplifier

A 5-Watt Socket Power Device Which May Also Be Used To Supply Plate Voltage To A Receiving Set

By Gerald M. Best

THE advantages of using a power tube having an undistorted audio output of several watts in the last stage are well known to those who have used the factory built power amplifiers employing the UX-210, CX-310 tube, or 205-D. Constructional details on power amplifiers using these tubes have appeared in past issues of RADIO, the most important having been by H. W. Armstrong in February, 1926 RADIO.

Since that time, improvements in rectifier tubes, resistors and other power apparatus have permitted the construction of a remarkably fine two stage amplifier and B power supply, which is shown in Fig. 1. This amplifier is designed to be connected to the output of the detector tube in any receiving set, or where circumstances permit, or require it, the amplifier may follow the first audio stage in the receiver, making a total of three stages of audio amplification. Except for the filament supply to the first tube in the amplifier, the outfit runs entirely from the a. c. lighting socket.

The circuit diagram is shown in schematic form in Fig. 2. The amplifier consists of a high grade input transformer ahead of a CX-340 high- μ tube, a stage of resistance coupling with grid impedance, and a CX-310 power tube, with output transformer or filter connected to the loud speaker.

The plate supply for both tubes is obtained from a single half-wave rectifier tube, the new CX-381, which will deliver 125 milliamperes at 450 volts if needed. After passing through a filter, the plate supply is fed directly to the

plate of the power tube through the output device, and is reduced to 180 volts effective at the plate of the high- μ tube by means of a 300,000 ohm resistance.

The rectifier system is also available as a B supply for the tubes in the receiver, by tapping a resistance shunted across the output of the rectifier filter circuit, the taps being so arranged as to provide voltages of 90, 67, 45 and 22 with the current drain of the average receiving set. C voltage for the high- μ tube, approximately $4\frac{1}{2}$ volts, is obtained by using the voltage drop across a 100 ohm resistance placed in series with the negative B supply, through which the plate current of the two tubes must pass. The C voltage

for the power tube is had by the same method, using the drop across a 1500 ohm resistance. A 1 mfd. bypass is used across each of the resistors to prevent audio frequency oscillation. The filaments of both power and rectifier tubes are lighted from 8 volt windings of the power transformer. The power tube negative B connection should be to the center tap of the secondary winding.

Instead of using a grid leak in the grid circuit of the power tube, a choke coil of at least 100 henrys inductance is used, in accordance with present-day practice, thus permitting the power tube to be somewhat overloaded, with the grid swinging positive, at frequent intervals without any distortion being ap-

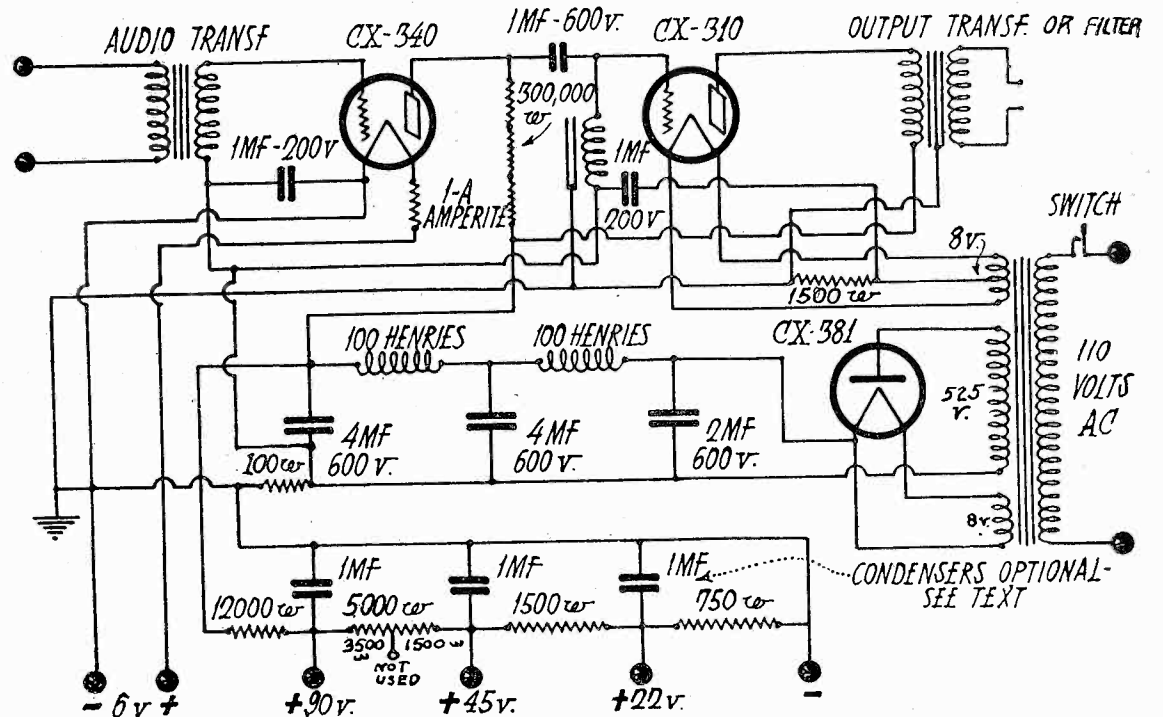

Fig. 2. Schematic Circuit Diagram

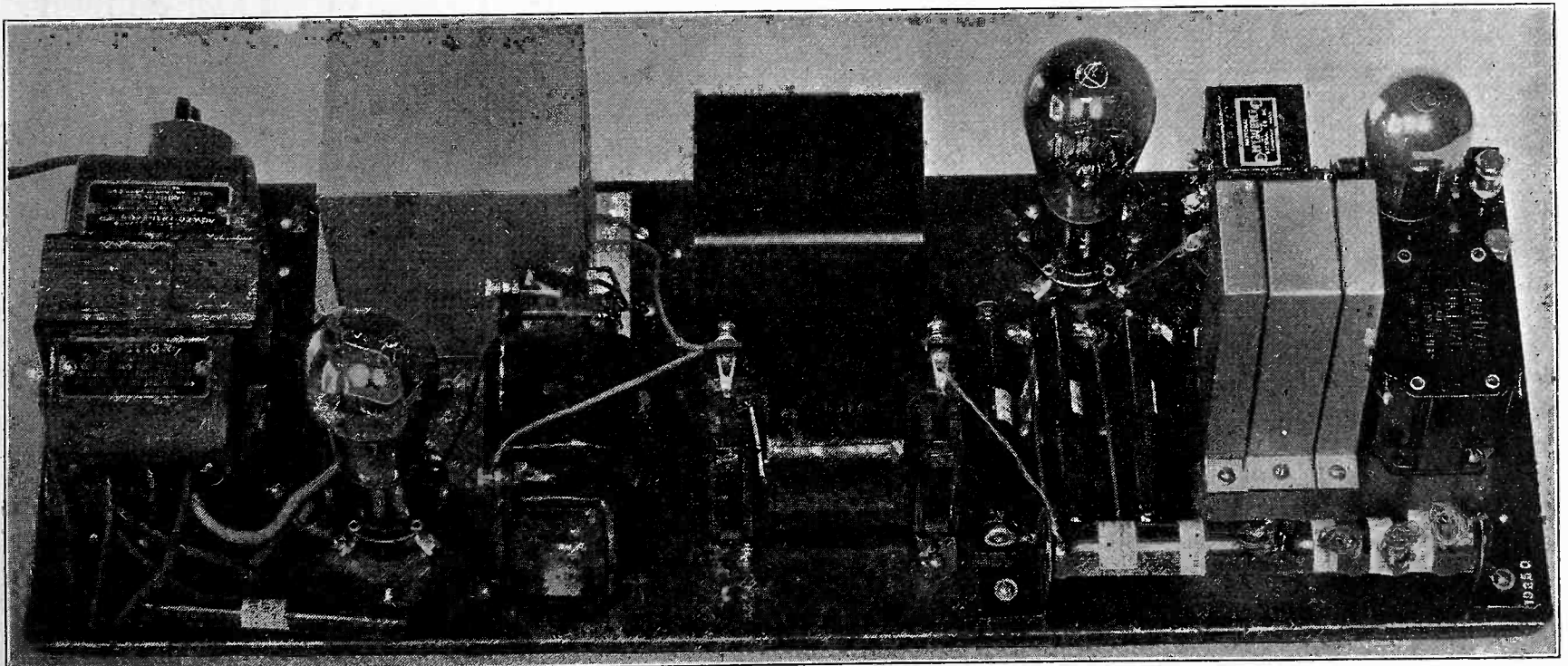

Fig. 1. Two Stage Power Amplifier with Rectifier

on No. 2 setting, which is for 118 volts.

A National Impedformer is used as the grid choke. The grid leak accompanying it is not used and the connections to the choke are to the —A and G terminals.

The 1 mfd. bypass condensers shunted across the two C biasing resistors may be of the 200 volt type, since the voltage across them does not exceed 30 volts under any circumstances. The 1 mfd. condenser between the plate of the high-mu tube and the grid of the power tube must be the same working voltage as the filter condensers, so that it should be of the 600 volt size. The plate resistor for the high-mu tube will carry .7 milliamperes plate current, so that a resistor of the lavite type will be large enough to dissipate the power involved. Three resistances of the 100,-

which should read 22 to 25 milliamperes. If the plate current is very much less than this amount, either the plate voltage is too low, or the C biasing resistor is greater than 1500 ohms. The correct C voltage for the type 310 tube, with 425 effective volts plate, is 35 volts; a high resistance voltmeter placed across the C biasing resistor will quickly tell the value of the effective V voltage, in case the exact value is wanted. The plate current of the high-mu tube should be .7 milliamperes, with 4½ volts negative grid potential. With no load, the current drawn by the tapped B resistor for the receiving set will be about 20 milliamperes, so that as a check on the voltage at the output of the filter, a milliammeter placed in series with this resistor will quickly give an indication of whether the output

power tube plate current to increase to such an extent that the power tube plate would become red hot, and should this actually occur, remove the 1 mfd. condenser and place it across the output of the filter for a few seconds. After the condenser has become fully charged, remove the connections, and after waiting a few seconds, short circuit the condenser. If it gives a fat, snappy spark it is in good condition, but if the spark be very weak, or there is none at all, it is leaky, and should be replaced.

COLOR DESIGNATIONS OF RADIO CONDUCTORS

An understanding of the standard Nema color code facilitates the tracing of the circuits in a factory-built receiver and its adoption by the radio builder enables others to trace through his circuits more easily when shooting trouble. The code consists of various combinations of seven distinctive colors including black, red, yellow, maroon, green, blue, and brown — which are woven into the insulation of the wire.

A solid color, without tracer thread, always represents positive polarity. Red designates the circuit carrying the highest voltage, such as the plate circuit of the power output tube. Maroon designates the plate circuit of the detector tube, yellow the filament circuit and green the grid circuit. Blue designates the antenna circuit and brown the loud-speaker cord. Any loose jumper wire, such as used to connect battery cells or other purposes where polarity is not considered, is black.

A single tracer thread of one color in a black or colored background always represents negative polarity.

Combinations of two or more colors in the outer braiding of a single conductor are used to indicate circuits using this as a common conductor. Or to indicate an intermediate plate voltage, the color for the circuit of the next higher voltage is combined with the color for the circuit of the next lower voltage so as to give a mottled effect.

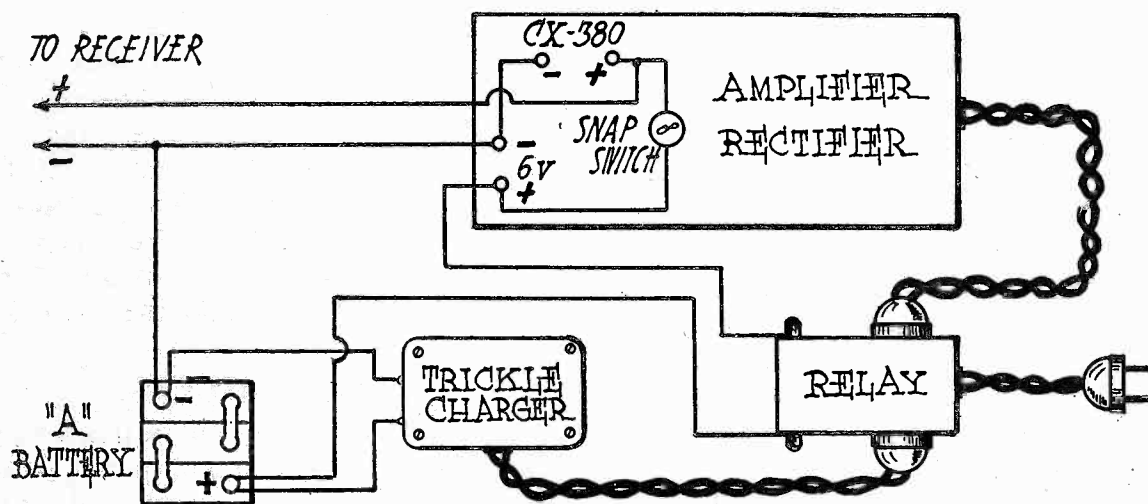

Fig. 4. Battery and Relay Connections

000 ohm size, placed in series, will give the correct total. They may be mounted on a strip of bakelite, placed between the two amplifier tubes.

Upon completing the wiring, insert the three tubes in their sockets, and light the filament of the high-mu tube. Turning on the 110 volt supply, the filaments of the power tube and rectifier should light, and if the loud speaker is plugged in the output, tapping the high-mu tube should produce a ringing sound in the speaker.

If a milliammeter is available, measure the plate current of the power tube,

voltage is greater or less than the expected value of 425 volts.

In shooting trouble in this amplifier, always remember that the voltages involved run as high as 500 volts d. c., and 525 volts a. c., so that care should be taken to keep the fingers away from exposed terminals. As a rule, there will be little trouble experienced in building this outfit if all the apparatus is in good working order when installed. Perhaps the hardest case of trouble to locate would be a leaky 1 mfd. plate coupling condenser between the two amplifier tubes. This would cause the

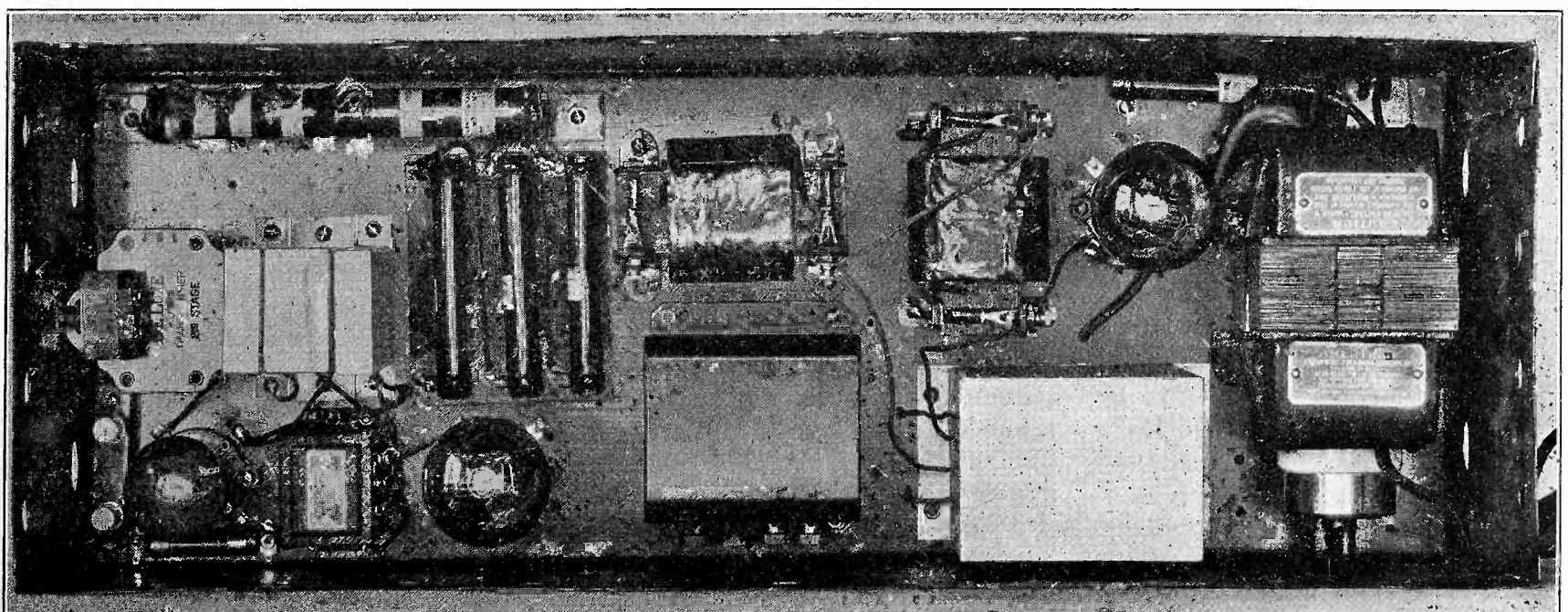

Top View, with Equipment Mounted in Metal Housing

Choice and Treatment of Wood for Shop Purposes

By Samuel G. McMeen

MANY problems of the experimental shop are first attempted in wood, even though the finished device would well be made of metal. For such purposes there is no wood quite as satisfactory as well seasoned birch. It is close-grained, it is hard, and it has no decided tendency to warp. It has no oiliness to cause it to repel glue and can be stained to match mahogany. One of the manufacturers of manual telephone switchboards uses large quantities of birch in close association with Tobasco mahogany and stains it so closely that the difference is only perceptible to the most closely scrutinizing eye.

None the less, there are occasions when real mahogany seems to be the best material, and in such cases it is well to use the hard and dark Tobasco mahogany. Philippine mahogany is a soft, light colored, rough grained material that is used for general building purposes in those islands. It has but one outstanding virtue, which is its lack of tendency to warp. Tobasco, like all other mahoganies, does not warp, takes a good finish, and is light in weight and reasonably close grained.

The one drawback to a wide use of mahogany of the better grades in the shop is its cost. This difficulty can be minimized by using it as a veneer on the surface of basswood or other soft fibre. In this form the veneer is "unrolled" from the log in an endless sheet by means of knives used as turning tools, and then glued up with, usually, three cross-laid sheets of the softwood. The result of this laying of the grain of the woods at right angles is to produce a board that can not warp appreciably even under the most severe conditions, and herein lies one of the chief virtues of such plywood.

Birch is also made up in the form of plywood, and is most useful in the making of panels for radio experimentation and for temporary or trial mount of apparatus, such as the assembly of small switchboards. It, too, has the virtue of not being subject to warping. For radio panels the birch material can be had as thin as 3-16 in.

For objects that require a specially high finish such as a gavel in which the chief requirement is looks, snakewood is good. It is of a dark reddish color—perhaps a deep tan—and is mottled with darker spots and stripes. It is also known as leopard wood. It is one of the closest grained woods obtainable.

It is so dense that it will take a high polish under the tools and abrasives even without varnish or French polish, of which treatments we shall presently speak. If it is not at hand in sufficiently large pieces, it can be glued up from smaller sections by the use of the glue described earlier in this series under the name of Armenian cement, an adhesive every self-respecting shop should have.

For some uses there is the requirement that the wood shall be light and at the same time stiff—have spine or backbone. The Forest Products Laboratory at Madison, Wisconsin has found that the wood having the greatest ratio of stiffness to weight is Douglas fir, known commercially as Oregon pine. This wood is widely used for building purposes. It is characterized by marked streaks of resin, slightly darker in color than the cellulose between those streaks. Its weight varies considerably, and for some exacting uses this is a drawback. The wider the streaks of resin-impregnated wood, the stiffer the sample. After all, such wood is merely a union of cellulose and resin, and the more of the latter the greater the stiffness and weight. Next in these respects is Port Orford cedar, sometimes known rather indefinitely as white cedar. It is of even texture, has no resin that is apparent to the eye, is lighter, bulk for bulk, than Douglas fir, is most delightful to work under the tools, and serves many a useful purpose.

For the finishing of wood, there are in general three choices. For patterns and the cruder devices built of wood, the usual method is to finish in shellac. The other two methods are respectively varnish and French polish. As to the first-mentioned process, there is nothing to be said except that there are two forms of shellac varnish. One is of orange shellac, best when covering power is the desideratum and color makes no difference, and the other is white—or bleached—shellac, useful where the color of the finish needs to be light. White shellac has no other virtue.

Varnish is like paint, an extremely vague substance. Its good qualities vary with the needs of the case. If resistance to abrasion and to moisture are among the requirements, then choose a spar varnish. Some spar varnishes will dry over night. The satisfaction of getting the right varnish is so great that we urge the shop worker to clarify his needs in his mind and then to put the

problem up to his dealer, whose advice generally will be reliable.

French polish is the quickest and one of the most beautiful finishes to accomplish. It is not to be recommended where there is much handling or other rubbing of the surface. It is done as follows:

Provide a soft (worn) linen cloth and a wad of absorbent cotton. Dip the cotton into shellac, cover the wetted portion with the linen cloth, spread boiled linseed oil on the linen cloth, and rub the work in sweeping strokes. The oil lubricates the pad and the shellac comes out bright and shining. Go over the surface of the work once, let it dry an hour, apply a second coating, and so proceed till you are satisfied. Ten applications are not unusual in fine work, but the labor is light and the reward is great.

HANDY HINTS

An easy way to lay-out a panel is to make a full-size drawing on heavy paper of how the finished panel will look, marking down the exact location of each hole with the size drill to be used for it; and then transferring the dimensions to the panel by stepping them off with dividers. A double circle should be made in the drawing for holes that are to be countersunk. After the holes have been located on the panel, they can be center-punched and drilled with the size drill indicated. Another method is to glue the drawing to the panel and center-punch the holes right through it. Either of these stunts will cut down considerably the time necessary to lay-out and drill a radio panel.

An insulated counterpoise will work very well in place of the ground on a receiving set. In locations where the earth is sandy or dry and a good ground connection cannot be obtained, a counterpoise is superior to a regular ground connection. A counterpoise is constructed exactly like an aerial; and is suspended directly beneath the aerial and near to the earth. It is connected to the ground binding post on the receiving set in the regular manner. Both the counterpoise and the lead to it should be well insulated from the ground. As in the aerial and lead-in, it is best to use enamel copper wire, about No. 12, in the counterpoise. A receiving set using an insulated counterpoise instead of a regular ground connection is not so likely to pick up interference from electric light lines, vacuum cleaners, door bells, and telephones.

"Sweetheart's Love Affair"

By Jan Dirk

PERHAPS you read the first story about Sweetheart in the May, 1926 number of RADIO. You never happened to think, did you, that Sweetheart might be a real man? Well, he is. I was with him on the cruise down the coast of Africa, and when I decided it was time to get off a tramp steamer and get a job in the passenger service, which I did, who should turn up but Sweetheart!

We left Victoria together on the same ship, a big twenty thousand ton barge carrying passengers, three classes, and freight to the Orient on a six weeks' trip from Japan to Manila and then back again and across home to Victoria. I don't dare give the name of the line, this time, for I still am pounding brass for them.

At any rate we steamed out of Victoria with two or three hundred passengers for this six weeks cruise, mainly school teachers and such, and while I held forth in the radio room with one other operator, Sweetheart was quartermaster again and took his trick at the wheel. In the shack it wasn't such easy pickings, for with only two ops it was necessary to stand six hours on and six hours off, night and day. But our troubles were alleviated somewhat since it happened to be a Canadian-listed ship that was entitled to carry a bar on board.

Out of Canadian ports the ships bound for the Orient go north to about 18 degrees below the pole, for up there the degrees are narrow and the distance is shorter. We followed across the chain of the Aleut Islands, and believe me it gets cold. Then when you're about a week out, you fall out of this zero weather into the dripping blazing heat of the Orient, and on the tenth day you pull into Yokohama. At least our run was ten days.

But I'm getting ahead of my story to discuss steamer time-tables. We got into Yokohama and the passengers went ashore for their first view of Japan, with the little Japanese customs officials bowing and grinning and trying to show off their knowledge of English. We stayed at Yokohama over night and then started out leisurely to tour down the coast of China to Manila, stopping at each port long enough for the passengers to be gyped by the local Big Business Men and come aboard with kimonos—incidentally that word is pronounced with no accent—and cloisonne and Da-



"I threw the switch and let him have it, and he came back."

mascene work, mainly junk. At each port we transferred cargo in chunks while the passengers were ashore.

Reaching Manila we started north again, with everybody sweating and my white uniform looking like it had been used to swab the deck. You simply can't keep the things stiff in such heat; they look like water-soaked street-cleaners' costumes after eight years of wear.

We got into the China Sea, and the sky got red. Also the sea dropped flat and lay like a piece of linoleum with vaseline smeared on it. A Manila saloon man was up in the shack having a cocktail with my partner and me. He went to the rail and actually got pale. "My God, I've been through three of 'em and I don't want another," he came back and told us. "Typhoon!"

I was tickled to death. I thought a typhoon would be fun. I changed my mind that night when we ran into a corner of it in spite of the fact that the skipper had been dodging the storm all day.

But I've forgotten to tell you what happened. As I said, this was a passenger ship, so we had a cigar counter, and over this counter presided a pretty little girl. You may remember that Sweetheart was over six feet and over two hundred pounds, with a pink-cheeked baby face and blue eyes. The little cigar girl saw him, and he saw her. It was a case of mad attraction from the start—this in spite of the fact that the purser, a sour-faced fool, was in love with the girl and was sure that he could get her to marry him soon. Sweetheart and the girl had been together more and more frequently as the weeks went by—we had been out a

month. Naturally the purser didn't like it, and he was a tough bird.

Well, the typhoon came at night. It wasn't fun. There wasn't any spectacle to see. A typhoon, I learned, is simply a hundred mile wind that flattens out the sea and hits the ship strong enough to squirt water around the edges of *bolted ports!* That's no lie. The passengers were locked in, off the decks. My partner was on watch, so I managed to get out on the boat deck to see what I could see. At first I couldn't see anything. Then I saw Sweetheart, standing holding to the rail and leaning into the wind—glorying in the storm. A moment later I saw another man crawl across the deck on his hands and knees in the blackness—it was impossible to stand up unless you held onto something—and leap up to hit Sweetheart behind the ear. The blow came from behind. Sweetheart turned and received another one in the face, and then closed. I don't think he knew who it was; he fought in self-protection. And it was a wild fight, I almost forgot the bigger fight with the typhoon for watching it.

Then I happened to remember something. Sweetheart's trick at the wheel was due to start in a few minutes. If he fought he would enter the wheelhouse—the bridge, that is—all cut and disheveled. The Captain must not see him that way. I tried to fight the wind and get down the ladder to warn Sweetheart, but before I could do it safely the fight was over. The bell had struck and Sweetheart had simply knocked the man to the deck and worked to leeward and finally up the ladder to the bridge. The Captain saw him with a bloody

nose and knew, of course, that he had been fighting recently enough to have nearly missed his watch.

The typhoon blew on, shrieking along toward Hawaii. The sea is flat during a typhoon. As soon as the storm was past, one wave knocked away a steel ladder seventy feet above the water. I remember that, because I was so seasick at the time. I remember lots of things that came up while I was sick.

Sweetheart told me that the Captain said to him. "Never let me see you fighting again on my ship!" The Old Man's nerves were about gone, after the typhoon. It's no pleasure to have an expensive ship and several hundreds of lives on your hands; you couldn't blame him. Of course whoever picked the fight with Sweetheart did it partly from hate and partly to get him in trouble; the fight was very carefully timed so that the Old Man would see the boy all mussed up, at the wheel.

Two days later, while we were still roaming northward after having touched at Shanghai—we were headed for Japan again before making the return trip across to Victoria—there was more trouble. The Captain and the two junior officers of course took shots at the sun every noon. It was discovered that we were knots off our course. The matter was looked into. Sweetheart had been at the wheel again at the time during which the ship must have gone wild, it was discovered. He got another bawling out from the Captain, for this was a serious offense—enough to rate his being discharged as soon as we arrived home.

By this time, putting two and two together, I knew what was up. The purser was trying to get Sweetheart out of the way so as to leave the road clear, where the girl was concerned for himself. The purser was a big man too, and ugly. He had been keeping out of the Captain's way so that his black eyes wouldn't be noticed; the rest of us noticed them, but on the ship things were never said about black eyes; someone was always getting drunk and fighting and it was best to hush the matter up as quickly as possible.

We used a gyro-compass, the moving parts of which were in a little room three decks below the bridge. Someone, I figured, must have thrown the gyro out of kilter just during Sweetheart's trick at the wheel. I knew who that Someone was. But I couldn't say anything, even when I learned that the purser was passing the story about, in such a manner that it would reach the Captain's ears, that Sweetheart had been drunk while at the wheel. This was a capital offense. The Captain heard, and because there was certainly enough circumstantial evidence, be-

lieved. It was accepted that Sweetheart would be fired as soon as we reached the home port. None of us liked it, but what could we do?

The purser must have chuckled at his own cleverness. There were two counts against duty, Sweetheart's duty, now: fighting when he should have been coming on watch, and getting the ship off her course.

Marion, the little cigar counter girl, often came up to the boat deck to visit us in the shack. We were like a family on the ship, that was one nice thing about it. She waited till the other op left and then said to me, "Bill,—I don't know what to do. Sweetheart seemed like such a nice boy, and I like him so much—and yet,—Well, Merrick told me that Sweetheart sneaked up on him the other night and started a fight. That's how Merrick got the black eye. A fight. Fighting over me, like a beast! I couldn't have believed it of Sweetheart." She shuddered.

"Merrick's a dirty liar," I told her. I could have killed Merrick, the purser, at the moment. But Marion went away believing that Merrick had told the truth. She thought I was just trying to stick up for Sweetheart, and she believed the purser was too honorable to lie to her. Oh, he was a clever dog, and a dirty one.

Well, we got into Yokohama. It is always an impressive thing to watch a great ship nose into port. We steamed in slowly and tied up at our own concrete dock, a great smooth expanse like a road.

We had just made fast and were about to open our side-doors for them to run up the gang-plank from the wharf. The passengers were getting ready to go ashore, and so was I; I wanted to go up to the Benten-Dori and get an ivory cigarette holder. Everything was poised, waiting. We had arrived just in time for the show, as it were. Rumble, rumble—

Crash! The wharf swung out like a snake, concrete splinters flying into the air, and struck the ship's side. Earthquake!

The big earthquake that laid Yokohama in ruins and changed this beautiful little city into row on row of streets filled with galvanized iron shacks! Yes, I was there. So was Sweetheart.

Everybody went crazy, of course, on sea as well as on land. The shocks got greater. We could see the land rising and falling in waves. On the ship I ran to the radio room. Our cables had sheared off and the Old Man was trying to back her out into the harbor. The harbor was a mess. Most of the ships' anchor chains had snapped and they were drifting about, many with no steam up so that they could not get out of the way of the few boats like ours

who were trying to get out from the docks. A great freighter came roaring in and tried to berth next to us, missed, and crashed into us amidships, cutting us badly but not dangerously. We couldn't get away. Fire had burst up in a dozen places ashore, and was sweeping down toward us.

Someone else was at the wheel this watch. I found Sweetheart in the shack, ready to help if we needed him. He of course having always been interested in radio, because of that Martian rat, knew the code, although not well.

Finally we managed to back away from the wharf and get into open water where we dropped anchor. Broken anchor cables from some other ship had tangled about two of our four propeller shafts, so that we could not move straight ahead but had to travel in an arc. We had to anchor there and stay for two days before an American destroyer could loan us a diver to cut away the cables.

So we watched the quake and the fire, trying not to hear the horrible screams that the wind brought out to us with the smell of burning bodies. In danger of being blundered into by other ships trying to fight their way out of the harbor, we stayed there and watched the ghastly picture to the end.

Earth and sea quiet again, and we all went about with hushed voices and with a queer dim look in our dull eyes, and thought we were living a dream and could not believe what we had seen. They began bringing wounded and homeless people out to the ships in launches. Our hallways and saloons were filled with strangers, Japanese mostly, sleeping on piles of whatever they had saved. All the boats in the harbor took their share. Marion was working day and night, helping the doctors dress wounds; she was wearing herself out.

Being interested in that sort of thing I asked one of the doctors who had come out from shore how the city lay in regard to communications.

"All the wires are down," he told me. "We tried to send calls for help through to Tokio but there is only one station—one radio station—in Yokohama, and its aerial is down."

I had of course been trying to work through to Tokio myself, but a Japanese warship in the harbor had better power than my 2kw, so I relinquished my attempts to her, as did the rest of the merchant ships at Yokohama. It was almost impossible to get through, though, as I could tell from listening to the battleship. The earthquake had done something to atmospheric conditions, for one thing, and then the receiver at Tokio was notoriously poor, used only for copying the high powered commercial station at Yoko. The way

(Continued on page 46)

Phase Relations in Radio

An Explanation of Their Meaning and of Their Influence on The Stability of Audio Amplifiers

By J. E. Anderson

MANY otherwise mysterious troubles due to oscillation in audio frequency amplifiers can be readily understood and corrected by studying the effect of changing the phase conditions in a vacuum tube circuit. The cause and cure of "motor boating" in a resistance coupled amplifier is one frequent trouble which may thus be clarified.

In this discussion it is assumed that the reader is already familiar with what is meant by phase difference between the emf (electromotive force) and current in an alternating current circuit. If the circuit consists only of resistance, the emf and current are in phase.

If there is both resistance and inductance in a closed circuit the current will lag behind the emf by an angle depending upon the relative values of the resistance and the inductive reactance. If the resistance is relatively large the angle of lag is small and the current is nearly in phase with the emf. If the reactance is relatively large the current will be nearly 90 degrees behind the emf. If the reactance is equal to the resistance, the current lags 45 degrees behind the emf. The current can always be resolved into two components, one of which is in phase with the emf and one of which is a quarter period behind it.

When an alternating emf is acting in series with an ideal condenser, that is, one without resistance, the current leads the emf by 90 degrees. It has its maximum value when the emf is zero, or a quarter period before the emf reaches its maximum.

When there is a resistance in series with the condenser, the angle of lead is less than 90 degrees, the actual value of the angle depending on the relative values of the resistance and of the reactance of the condenser. The reactance is inversely proportional to the capacity of the condenser and to the frequency of the emf. If the resistance is equal to the reactance the angle of lead is 45 degrees, or the advancement of phase is an eighth of a period.

When there are resistance, inductance and capacity in series with the emf, the phase angle between the emf and the current is still determined by the relative values of the resistance and the reactance. But the total reactance is now given by the difference between the reactances of the inductance and the condenser. If inductive reactance predominates, the current lags; if the con-

densive reactance is the greater, the current leads the emf.

If the two reactances are equal, one neutralizes the other, and the current is in phase with the emf. The circuit is then in resonance, or in tune, with the emf. This condition can be brought about by varying the inductance, the capacity, or the frequency. In most cases of tuning it is done with the condenser, but in the super-heterodyne it is done by varying the frequency.

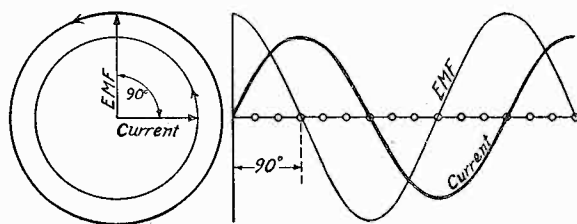

Fig. 1. 90 Degree Phase Difference

Fig. 1 illustrates a rotating emf vector acting in series with a pure inductance and the resulting rotating current vector. The current lags behind the emf by just 90 degrees, the rotation being counter-clockwise. The alternating components of the emf and the current along the conductor are shown at the right of the figure. Note that throughout the cycle the 90 degrees lag is maintained.

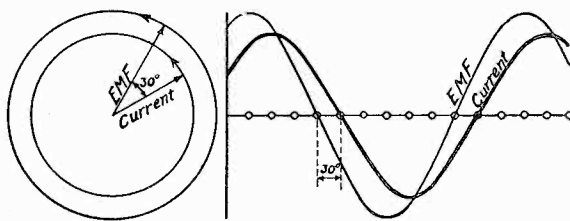

Fig. 2. 30 Degree Phase Difference

Fig. 2 illustrates the case of an emf, acting in series with a resistance and an inductance. In this case the current lags behind the emf by an angle 30 degrees. This phase difference is maintained throughout the cycle as is shown by the curves at the right.

When the grid potential on a vacuum tube is increased, that is, made less negative or more positive, the plate current also increases. Thus the plate current is in phase with the grid potential. This fact has been verified by every ex-

perimenter who has put a milliammeter in the plate circuit and varied the grid bias. But the plate potential, or rather the change in the plate potential caused by a change in the grid potential, is in opposite phase to the grid potential.

This statement, which has no significance unless there is a resistance or an impedance in the plate circuit, can best be proved mathematically. Suppose the load resistance on the tube is R and that the plate potential for a given value of grid potential is E_p . When the grid potential is increased the plate current is increased. Let this increase of current be i_p . This current causes a drop in the resistance R equal to Ri_p . Thus the plate potential is decreased to $E_p - Ri_p$. It is $-Ri_p$ which is of interest because it represents the alternating potential in the plate circuit, or the effect of the change in the grid potential. Since it is negative when the grid potential is positive, the two are in opposite phase.

Let us examine the phase relations of the currents and potentials in a typical four tube resistance coupled amplifier, such as is shown in Fig. 3. Assume that the capacities of the stopping condensers and the resistances of the grid leaks are so large that they have a negligible effect on the total load impedances or resistances, an assumption which holds in all properly designed resistance coupled amplifiers. Let E be a generator or other source of a simple harmonic emf.

Consider an instant when the polarity of the generator is as indicated by the signs. The current i_0 through the resistance R_0 is then as indicated by the arrow. The potential of the grid is then positive and equal to R_0i_0 , the potential drop in the resistance. An arrow a_1 is drawn pointing toward the grid of the first tube to show that the potential is positive. The change R_0i_0 in the grid potential will cause an increase in the plate current equal to i_1 , since the grid potential and the plate current changes are in phase. Being an increase, the arrow for i_1 is drawn to point toward the plate. But the change in the plate potential is $-R_1i_1$, as was shown above,

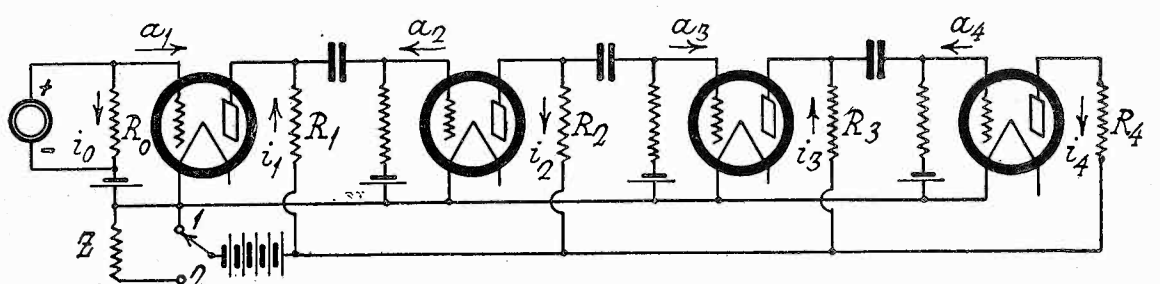

Fig. 3. Phase Conditions in a Resistance-Coupled Amplifier

and this becomes the grid potential of the second tube. Therefore the grid potential of the second tube is *decreased* by the amount $R_1 i_1$, a fact indicated by drawing an arrow a_2 pointing away from the grid. Thus the grid potential of the second tube is opposite in phase to that of the first tube.

The grid potential $-R_1 i_1$ will change the plate current in the second tube by $-i_2$. Since this is a decrease in the total current, the arrow for i_2 is drawn pointing away from the plate. Thus the plate current changes in the first and second tubes are opposite in phase. The voltage drop in the resistance R_2 is equal to $-R_2 i_2$, but the change in the plate potential is the negative of this, or $R_2 i_2$. This becomes the grid potential of the third tube. It is positive and therefore the arrow a_3 is drawn pointing toward the grid.

By the same reasoning we find that the change in the plate current i_3 in the third tube is directed toward the plate and that the change in i_4 , the plate current in the fourth tube, is directed away from the plate. Also that the grid potential of the fourth tube, as indicated by arrow a_4 , is directed away from the grid. Thus the grid potentials of two adjacent tubes are in opposite phase, and the grid potentials of alternate tubes are in phase. Also the plate currents of two adjacent tubes are in opposite phase and those of alternate tubes in phase.

Suppose now that the last tube has an inductance L_4 in its load in addition to the resistance R_4 . This inductance will retard the current i_4 , that is, cause it to lag behind the emf by an angle which is equal to the angle of the total impedance in the plate circuit. The total resistance is the sum of r_4 , the internal resistance of the tube, and R_4 , the resistance in the load. The reactance is the product of the inductance in the load and $2\pi f$, where f is the frequency. Hence the vector impedance is $(r_4 + R_4) + j_2\pi f L_4$, in which j is written in front of the reactance to show that this is at right angles to the resistance. The angle of this impedance can be found from a table of tangents.

Let $r_4 = 3,000$ ohms, $R_4 = 2,000$, $L_4 = 5$ henrys, and $f = 1,000$ cycles. Then the impedance $Z_4 = 5,000 + j31,416$, and angle of which is $80^\circ 57'$. This is equivalent to a time lag of 0.225 of a period, or in this case to 225 microseconds. Current i_4 lags that amount behind the emf in the plate circuit, or it is that amount out of phase with current i_2 , when the conditions are as assumed in this paragraph.

Since a vector can always be resolved into components at right angles, i_4 can be resolved into one component which is in phase with the emf and one which is at right angles to it. This can be done graphically or analytically. The inphase component is obtained by multiplying i_4

by the cosine of the angle of lag—and the right angle component by multiplying i_4 by the sine of the angle. The cosine of $80^\circ 57'$ is 0.157 and the sine is 0.987. Therefore the in-phase component of the current is $0.157 i_4$ and the right angle component is $0.987 i_4$. The effect of this phase shift on the behavior of a resistance coupled amplifier will be shown later.

The effective emf in the plate circuit of any tube is the product of the grid potential and the amplification constant of the tube. For example, if the amplification constant of the first tube is μ_1 , the effective emf in the plate circuit is $R_o i_o \mu_1$. If this is divided by the total impedance in the plate circuit, the current is obtained. Thus $i_1 = R_o i_o \mu_1 / (r_1 + R_1)$. If $R_o = 2$ megohms, $i_o = 1$ microampere, $\mu_1 = 30$, $r_1 = 0.15$ megohm and $R_1 = 0.25$ megohm, $i_1 = 150$ microamperes.

The phase relations of the plate currents in a receiver have an intimate bearing on the performance of the amplifier when all the tubes are served by a common source of plate potential. The common impedance either increases or decreases the amplification, depending on the direction in which the resultant of all the plate currents flows through the common impedance. This can easily be shown in connection with the resistance coupled amplifier in Fig. 3.

Suppose the plate return lead be switched to point 2 so that the impedance Z is common to all the plate circuits. This impedance may be a pure resistance, or an impedance having either inductive or condensive reactance. But assume for simplicity that it is a pure resistance. Also assume for the sake of argument that each stage amplifies by a factor of 10 so that any one plate current is just ten times as great as the current in the plate circuit preceding. Then if the first plate current is i_1 , the second is $10i_1$, the third $100i_1$ and the fourth $1000i_1$. The first current flows through Z in the direction of the plate but the second flows through it in the opposite direction. Hence the net current through Z from these two is $(i_1 - 10i_1) = -9i_1$. This net current is in opposite phase to i_1 . The voltage input to the second tube is $R_1 i_1 - Z 9i_1$. This is less than $R_1 i_1$ and therefore the amplification is decreased by Z .

If we now add the plate current in the third tube, the net current through Z is $100i_1 - 9i_1 = 91i_1$. This is in phase with i_1 , and now the voltage input to the second tube becomes $R_1 i_1 + 91Z i_1$. Thus when three of the currents flow through Z the amplification is considerably increased by Z . The increase, however, is reduced somewhat by the fact that the plate current in the third tube decreases the voltage input to that tube just as the plate current in the second decreased the

voltage input to that tube. Despite this there is a considerable increase in the total amplification when three plate currents flow through Z . Oscillation at a low frequency is highly probable and is almost invariably present in circuits of this type. It is that which is called "motorboating." The frequency of the oscillation is determined by reactances which are always present in practical receivers.

If the current in the plate circuit of the fourth tube be also added, the total current in Z is $91i_1 - 1000i_1 = -909i_1$. This is in opposite phase to i_1 and thus the total input voltage to the second tube is $R_1 i_1 - 909Z i_1$. As before, the plate current in the last tube decreases its own input voltage, but the same current increases the input voltage to the third tube. The opposing effects partially neutralize each other, so that the decrease in the input voltage to the second tube approximately measures the decrease in the amplification in the circuit as a whole. Hence the common impedance in a four tube circuit greatly decreases the amplification. Such a circuit cannot oscillate as long as all the plate currents flow through Z in toto. If a four tube circuit of this type does oscillate at a low frequency it simply means that not all the tubes are on the common impedance as a whole, although they may be on a smaller common impedance.

It often happens that a four tube circuit on a common impedance oscillates or "blasts" on a high frequency, say around 2,000 cycles. This can easily be explained. The last load impedance is never a pure resistance but always contains the reactance of the loud speaker. Thus the current in the last tube lags behind the emf in that tube, as has already been explained. Thus i_4 can be broken up into two components, one of which is in phase with the emf and one which is at right angles to it, that is, one which lags behind 90 degrees. The in-phase component is in opposite phase to i_1 and the right angle component is at right angles to it. The right angle component neither increases nor decreases the amplification; but the in-phase component does, and this can be treated just as the total current was treated in the preceding paragraph.

For low frequencies the inductive reactance of the speaker is very small and nearly all of i_4 is in phase with the emf. Hence nearly all of this current is in opposite phase to i_1 . Then there is no appreciable change over the case when the last load was a pure resistance. A four tube resistance coupled circuit on a common impedance will therefore be stable, or free from oscillation, at low frequencies. This has been verified.

As the frequency increases the reactance of the speaker will increase in pro-

(Continued on page 48)

The Static and Dynamic Characteristics of A Double-Grid Vacuum Tube

By Harry R. Lubcke

WITH the advent of commercial-ly available four electrode tubes a study of their characteristics becomes one of unusual interest, not only because of the quality involved, but also because such study gives much information as to the use and performance of the tube. It is the purpose of this paper, therefore, to present both the static and dynamic characteristics of such a tube, to compare and analyze these characteristics, and to indicate their effect on its operation.

By way of explanation it may be wise to state that the *static* characteristics of a tube are those determined by the use of direct current only, by the impressing of constant potentials on the grid and measuring their effect more or less directly; while the *dynamic* characteristics are those determined by the use of an alternating current, generally of fairly high audio frequency, simulating the condition of rapidly varying potentials obtained in actual use.

The characteristics determined by the tube testers usually found in stores repairmen's kits, etc., are the static characteristics. The dynamic characteristics require apparatus of laboratory caliber for their determination.

Fig. 1 shows the plate impedance (R_p) and mutual conductance (G_m) curves of a Van Horne double-grid tube for varying plate voltages, with zero voltage on both grids and the normal filament voltage of 5v. The curve plotted represents the actual a. c. plate to filament impedance, represented by the first derivative or slope of the grid voltage vs. plate current curve (not shown), and *not* the plate resistance which is the plate voltage divided by the corresponding plate current. This distinction between plate impedance and plate resistance is of importance because of the fact that the former is the characteristic dealt with in normal operation and also because it is generally about one-half the magnitude of the latter. The terms are often used loosely, which leads to confusion. The mutual conductance is, as commonly understood, the ratio of amplification constant to plate impedance.

It will be noted that the plate impedance of the tube is relatively high. By referring to the scale at the left, which reads in "ohms times 1000," it will be seen that at 150 volts plate voltage the plate impedance reads 100, which signifies its value is 100,000 ohms, as compared with about 10,000

ohms for the ordinary type 201-A. For lower plate voltages it is correspondingly higher as indicated by the curve, while for a value of 240 volts it has decreased to 80,000 as would be expected by a continuation of the curve shown. The tube is therefore comparable to one of the "high Mu" type in this respect.

The mutual conductance curve, being proportional to the reciprocal of the plate impedance, rises as the plate voltage is increased. Its absolute value is somewhat small due to the high plate impedance. It reaches a maximum value at 240 volts of 500 micromhos, beyond which point the measurements were not carried.

As shown on the graph by the solid line, the dynamic mutual conductance curve has a distinct convexity upwards, while the same quantity determined statically is practically a straight line over the same range. The exact reason for this is not known but it indicates an appreciable discrepancy between the static and dynamic values for this quantity that is also evident in the mutual conductance curves shown in Fig. 2.

Conversely, with the plate impedance curve the agreement is very good, so good in fact, that the static curve was not drawn in, in order to avoid confusion. The triangular dots around the dynamic curve represent the plotting of the static data.

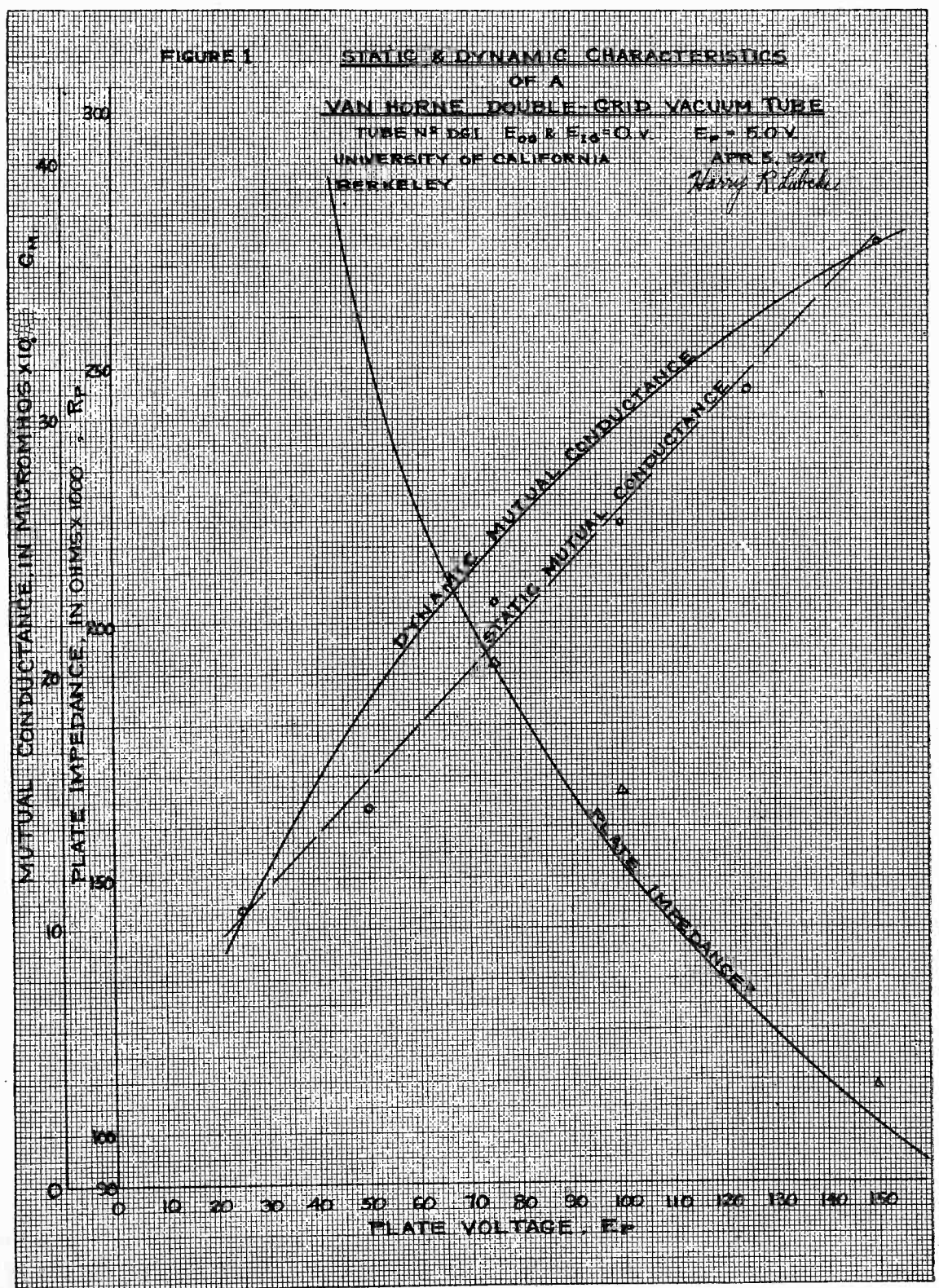

In Fig. 2 the dynamic and static determinations of plate impedance and mutual conductance are given for variation of grid voltage, one grid being held at zero potential while the other is varied to secure the curve. Here it will be noted that the values for the two determinations differ by a greater amount than was evident in the previous figure, indicating the greater effect of frequency on the characteristics when complex grid potentials exist.

Since the slope of the curves for the inner grid is steeper than that of the outer grid curves it will be seen that closer proximity to the filament gives the greater controlling effect. Thus a change in potential from zero to $-1v.$ on the inner grid causes a plate impedance change of from 110,000 to 135,000 ohms, while an identical potential change on the outer grid gives an increase of from 110,000 to only 115,000 ohms. This is due to the fact that the amplification constant for the inner grid is 40, while for the outer grid it is 8. The static determinations gave 41 and approximately 7.5; both static and

dynamic values being practically constant regardless of grid or plate voltages within the limits of 0 to 2 and 90 to 200 volts, respectively.

Comparing static and dynamic values of G_m it will be noted that the former are in both cases lower and more subject to the straight line or linear variation noted in Fig. 1. Correspondingly for R_p they are higher, though for the outer grid so close to the dynamic that the curve was not drawn.

It is interesting to note that the mutual conductance curves are convex downward while for all other three electrode tubes they are convex upward. This signifies a greater change of the ratio of μ (amplification constant) to R_p near zero grid consequently greater rate of decrease of plate impedance at this point for the four electrode tube.

The conclusions, and effect of various conditions of operation on the tube performance, based on the measurements made can be summed up as follows:

1. Over and above instrument errors there appears to be a change in characteristics with frequency on tube meas-

urements in general. Its cause is most likely the increase of condensive reactance with frequency, making the internal capacity of the tube an appreciable factor at high frequencies. The magnitude of this phenomenon at radio frequencies is at present open to conjecture, for very little work has been done in this field up to the present.

2. Because of the "Hi. Mu" nature of the tube it is desirable to operate it at a high plate voltage, values up to 200 volts being justified by the decrease in plate impedance obtained.

3. A C battery voltage of 1 volt or less should be used on the inner grid, 3 volts or less for the outer grid.

4. For maximum results in radio frequency amplification the plate impedance of the tube should be matched by that of the transformer primary. Since the impedance of the tube is high a higher matching value than ordinary will be required which can be secured by increasing the number of primary turns.

The best test for a new radio tube is to put it in a regenerative receiving set or oscillator and determine whether or not it will oscillate. This is true because a tube that will oscillate will also detect and amplify (the two other functions of a radio tube). This is the test often used by manufacturers and dealers. A tube that will not oscillate is practically worthless for any use but rectifying.

If a variable condenser is used in the primary circuit (the aerial circuit) of a receiving set, it is best to connect it on the ground side of the primary winding, with the rotary plates attached to the ground binding post, so that body-capacity effects will be minimized. The rotary plates of the secondary variable condenser should always be connected to the filament of the tube, never to the grid, for the same reason.

In a crystal receiver, the crystal should be cleaned every few months with a little alcohol and a piece of clean cloth to remove dust and grease and keep the mineral sensitive. Soap and water and an old tooth brush are also good for cleaning minerals. The end of the catwhisker that touches the mineral should be filed to a point occasionally to keep it clean and free of corrosion.

Where there is not enough room in the yard to erect an insulated counterpoise, a good one can be constructed in the cellar by running several wires the length of the house and supporting them on porcelain knobs or cleats fastened to the beams that hold the first floor. An insulated lead can be brought up through a porcelain tube in the floor of the radio room and connected to the ground binding post. Although the house is between the aerial and counterpoise, it has practically no effect on reception.

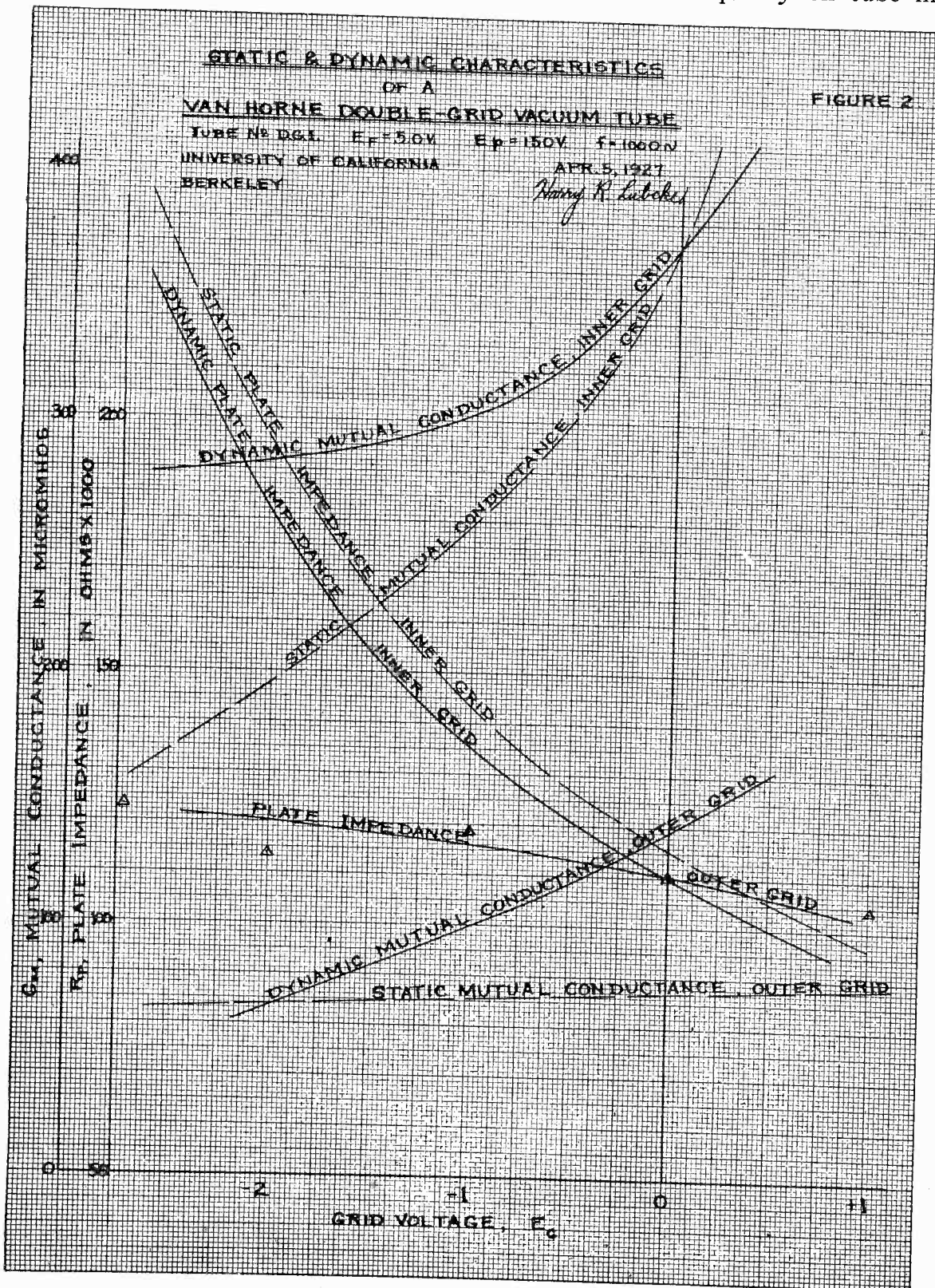

The Impedance Equalized Receiver

The Theory and Practice of A New Six-Tube Circuit Wherein Regeneration is Automatically Controlled by A Variable Impedance

By Francis Churchill

THIS receiver was designed to give uniform sensitivity over the entire broadcast band. After a discussion of the theory whereby it is accomplished, directions are given for the construction and operation of a practical set which efficiently accomplishes this purpose.

Most receivers are quite sensitive and selective on the shorter wavelengths but are broad and insensitive on the longer waves. H. J. Van der Bijl has proved that the regenerative effect in a tuned r. f. amplifier is an inverse function of the grid tuning capacity. This means that more regeneration is present on the shorter wavelengths where the tuning condensers are near minimum capacity.

circuit and the receiver discussed in this article is another.

This receiver acts as a normal r. f. amplifier at the lower wavelengths and has regeneration added gradually as the tuning capacities are increased. Thus as one source of regeneration is decreased, another source is increased, and the same sensitivity and selectivity are obtained over the whole band.

The method of doing this is entirely electrical and, once adjusted, does not need to be changed. A combination of inductance and capacitance is used to give an impedance which is nearly infinite at about 175 meters and only a few hundred ohms at 550 meters. This impedance equalizes each stage of radio

cum tube from the plate battery if wired through the primary coil as usual, a parallel feed through a radio frequency choke is necessary. These chokes should be of very high impedance to radio frequencies so as to minimize any loss through them. If chokes of low distributed capacitance and relatively high inductance are used, the chokes will act as minute condensers in the broadcast range and by-pass practically no radio frequency current, but will pass the necessary direct current from the B battery. This arrangement also keeps the r. f. currents out of the B battery where undesired feed-back might be set up due to the impedance of the battery common to each r. f. stage.

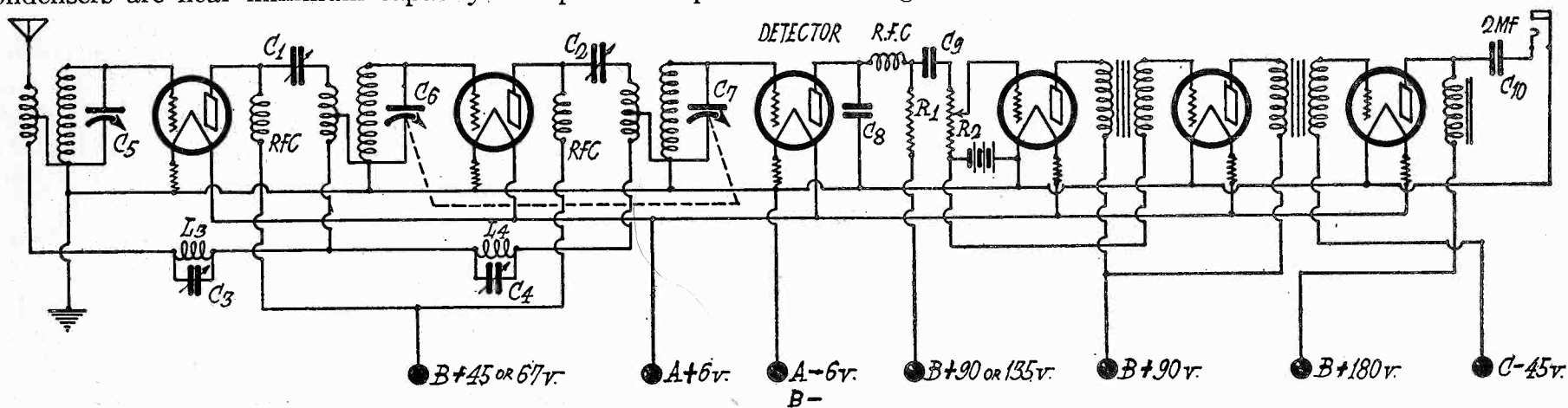

Fig. 1. Circuit Diagram of Impedance Equalized Receiver Constructed by Author

C_1 and $C_2 = .001$ mfd. max. $C_8 = .0001$ mfd. L_3 and $L_4 = 80$ turns, No. 32 wire, $\frac{1}{2}$ in. diam.
 C_3 and $C_4 = .0005$ mfd. max. $C_9 = .1$ mfd.
 C_5, C_6 and $C_7 = .00035$ mfd. variable. $C_{10} = 2$ mfd. $R_1 = \frac{1}{4}$ megohm leak.
 $R_4 =$ Modulator with filament switch.

As the effective resistance of the inductances does not increase on short waves as fast as the regenerative effect, the usual tuned r. f. amplifier receiver is thus more sensitive and selective on the shorter waves.

One way of overcoming the loss in sensitivity on the higher wavelengths is to mechanically couple the primary coil of each r. f. transformer to the tuning condensers so that more coupling is obtained at the longer waves. This method is used in several receivers and gives pretty good results. However, the real fault hasn't been overcome by this arrangement. It gives more sensitivity but not as much selectivity as it should, since the relative amount of regeneration is not the same as at the shorter wavelengths.

A better arrangement would be some electrical method of equalizing the r. f. amplifier over the whole band, since this would get away from moving coils and would be automatic in its operation. The Loftin-White circuit is one such

frequency amplification by regulating the feedback from practically zero at the shorter wavelengths to a maximum as 550 meters is approached. Automatic increase of regeneration equalizes the amplifier.

The circuit in Fig. 1 uses this "variable" impedance arrangement. Condensers C_1 and C_2 shift the phase of the voltage in the plate circuit sufficiently to prevent oscillation. The voltage fed back through the grid-to-plate capacity of the amplifier tube is changed enough so that it does not aid the voltage on the grid and so build up and cause oscillations. These phase changing condensers can be adjusted to just prevent oscillation and still leave a large amount of regeneration if such is desired.

It can be shown mathematically that a purely resistive or capacitive load in the plate circuit of an r. f. amplifier will not cause oscillations since the phase conditions are not such as to make that possible. Since this phase controlling condenser insulates the plate of the va-

This latter impedance varies with the age of a B battery and so is an undesirable factor.

The equalizing impedances Z_1 and Z_2 are coupled from the plate circuits back to the grid circuits through special windings in the plate circuit of each r. f. transformer. These windings are a few turns of wire wound in the same direction as the main primary and are in such a direction as to make a continuous winding with the secondary coil, one end of which goes to the grid and the other end to the impedance Z_1 or Z_2 . This coil arrangement will give the correct phase relations to aid and not oppose regeneration. The primary coil or coils should have a turn ratio of about 2 to 1 so that if 15 turns are in the main primary winding, the other winding will be of 7 or 8 turns. If too many turns are used in the latter winding, too much regeneration will occur at the higher wavelengths. With too few turns there is not enough regeneration for perfect equalization.

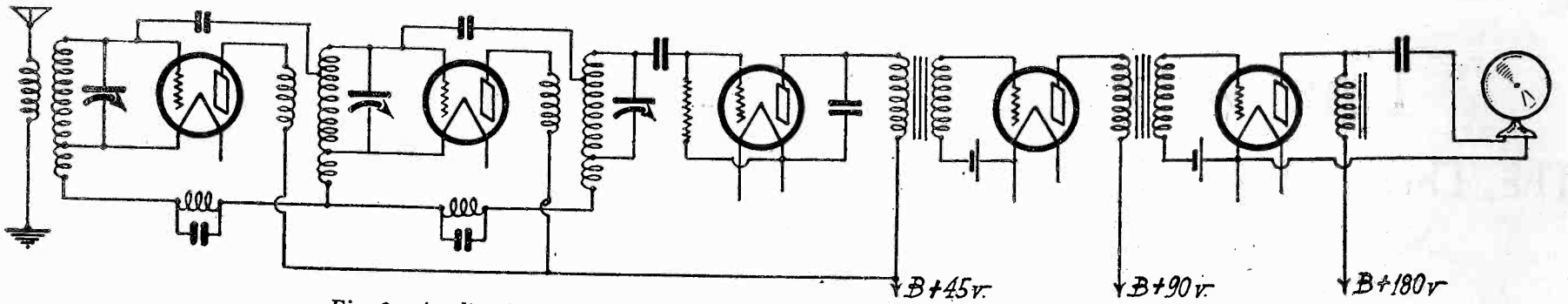

Fig. 2. Application of Impedance Equalized Principle to Typical R. F. Receiver

This same principle of impedance equalization can be applied to any tuned r. f. broadcast receiver using the typical circuit shown in Fig. 2. Here again it is necessary that the equalizing primary winding be in such a direction with respect to the secondary that regeneration will be increased and not opposed. The adjustments are generally critical for this type of receiver and the circuit shown in Fig. 1 is recommended as being more satisfactory.

CONSTRUCTION

THE actual set pictured herewith is a two-control six-tube receiver with separate volume control. Due to the aerial, the first r. f. stage will not tune exactly the same as the second stage and detector. The set is shielded to exclude nearby stations and to minimize electrostatic reaction between stages.

A grid bias type of detector was used because it gave less distortion and greater selectivity than was obtainable with grid-leak and condenser. The latter, however, is more sensitive. Resistance coupling is used in the three-stage audio amplifier so as to have a high plate impedance to match the high plate resistance of the detector. It also provides a ready means of volume control.

The three-stage audio amplifier was designed with a slightly rising high frequency characteristics so as to partly compensate for the loss of the edges of

LIST OF PARTS USED

- 3 Hammarlund .00035 mfd. Midline variable condensers.
- 3 Hammarlund Auto-couple r. f. transformers.
- 3 Hammarlund Aluminum shielding cans.
- 1 Bakelite or Formica panel 7x24x $\frac{1}{8}$ in.
- 1 Wooden or fibre baseboard 12x23 $\frac{1}{2}$ in.
- 2 Kurz-Kasch vernier dials.
- 2 Samson Symphonic audio transformers.
- 2 Samson Output chokes.
- 3 Samson No. 85 r. f. chokes.
- 5 Frost tube sockets.
- 1 Benjamin tube socket.
- 2 X-L Variodensers Model G-10.
- 2 X-L Variodensers Model G-5.
- 9 X-L Push binding posts, aerial, ground, -A bat., A bat., -C bat., 45 volts, 90 volts, Amp., 135 volts.
- 1 Centralab Modulator—500 MS switch type.
- 1 .0001 Sangamo by-pass condenser.
- 1 .1 Sangamo by-pass condenser.
- 2 1. mfd. Electrad by-pass condensers.
- 1 $\frac{1}{2}$ megohm Electrad leak and mounting.
- 5 1A Amperites.
- 1 112 Amperite.
- 1 Electrad open circuit jack.
- 4 CeCo tubes.
- 1 CeCo Hi Mu tube.
- 1 CeCo Power tube.

the side-bands due to the extreme selectivity of the receiver.

Fig. 3 shows several gain-frequency curves taken from the receiver as constructed in accordance with the suggestions to follow. The drop of 5 transmission units between 1000 and 30 cycles in the audio amplifier curve A represents a volume change of only about 10 percent. The audio amplifier is capable of giving 60 T. U. gain when the volume control is adjusted to maximum. Curve A was purposely taken with moderate volume for local reception.

The other curves show the effect of regeneration adjustment of the phase

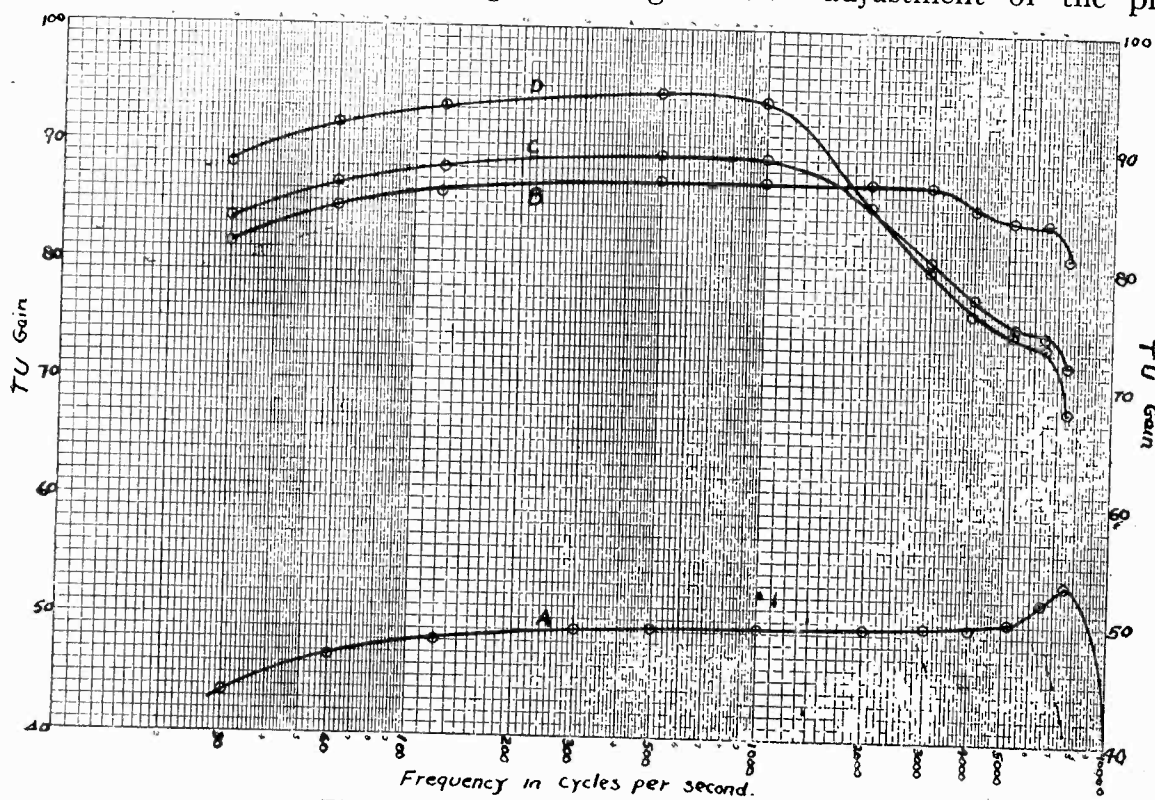

Fig. 3. Gain-Frequency Characteristics

"A" Curve for Three Stage Audio Amplifier with Resistance Across Output.
 "B" Curve of Over-all Amplification with Phase Condensers Adjusted for Minimum Regeneration.
 "C" and "D" Curves of Over-all Amplification with Phase Condensers Adjusted for Greater Sensitivity.

condensers. Curve B shows the result of practically no regeneration and C and D show the effect of increasing regeneration to get distance. For the latter adjustments the music sounds drummy. For normal operation such enormous gain is undesirable and the quality may be improved at the expense of volume by shifting the phase condensers.

The apparatus is mounted on a 7x24 in. panel and on a 12x23 $\frac{1}{2}$ in. baseboard. The panel is supported by the shields, and also by three woodscrews along the lower edge. The arrangement of the parts used by the author is shown in Fig. 4, though the exact location of any of the parts is not important and can be moved around to suit the individual constructor.

The easiest method of constructing the set is to assemble all of the parts except the sides and tops of the shielding cans, in their proper locations and then screw them down to the baseboard. Before fastening the panel to the baseboard, all of the holes necessary for wiring the set should be drilled adjacent to each part. By running all of the battery leads and a few of the plate circuit leads through the baseboard, the usual maze of wiring is eliminated. The insulated wires, run directly from hole to hole on the under side of the baseboard. Incidentally this type of wiring is a great time-saver and the entire set can be laid out and wired in one or two evenings.

The r. f. transformers are mounted directly on the rear of the variable condensers with supports supplied with these transformers. A glance at the picture of this set shows the set up of the coils and condensers. By using the complete assembly, shielding can, r. f. transformer and variable condenser, the proper spacing is obtained between the coils and the sides of the metal cans. If homemade cans are used, they should be large enough to keep an air clearance of about 2 in. or more on all sides. The

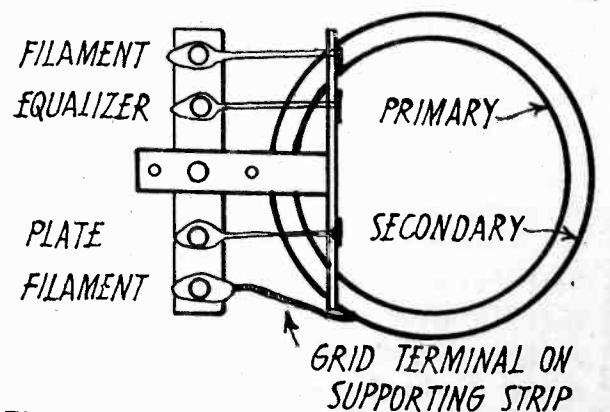
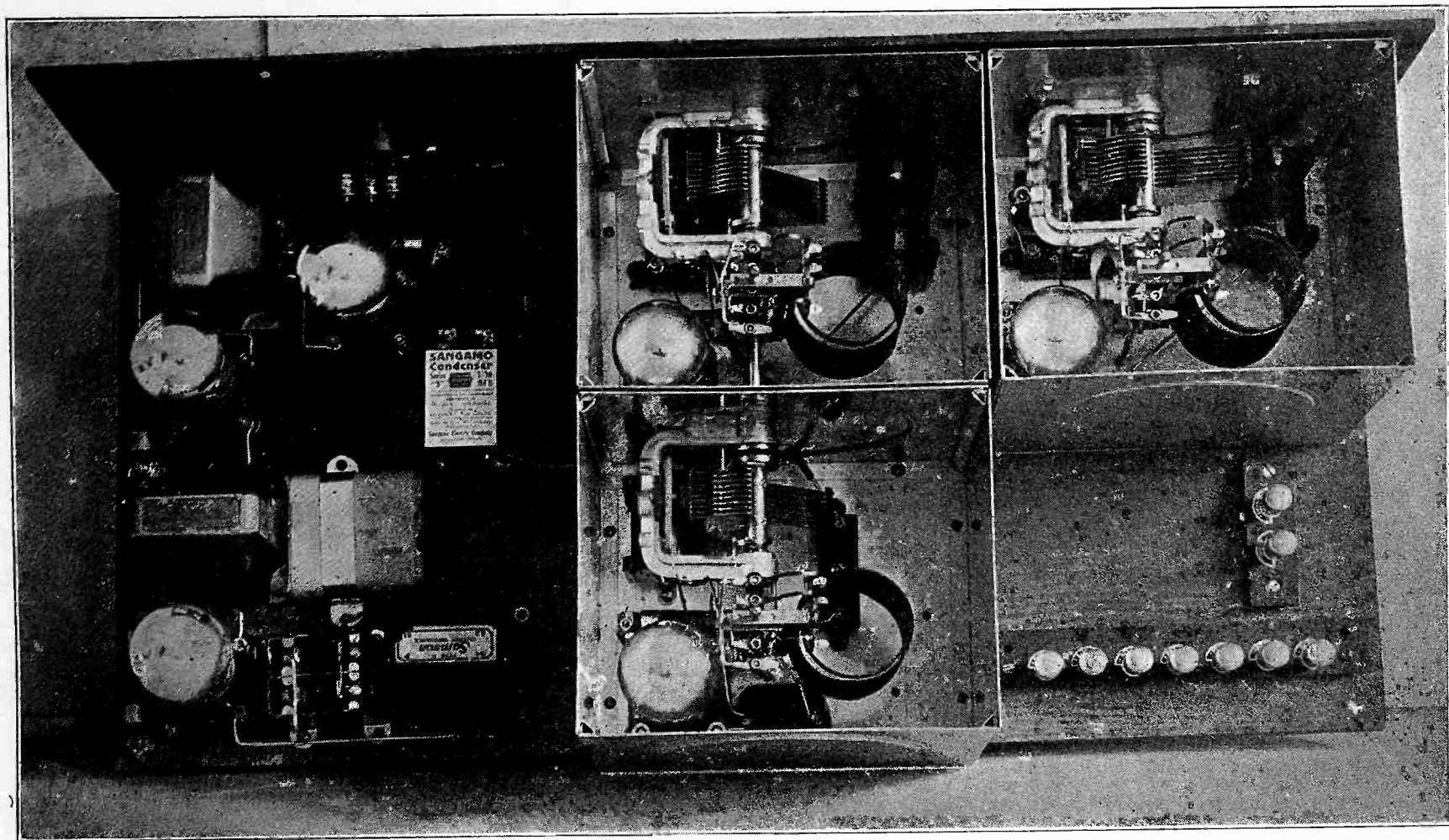

Fig. 5. Wiring of R. F. Transformer Terminals



Impedance Equalized Receiver Made by Author

proper wiring designations for the r. f. transformer terminals are shown in Fig. 5.

The special equalizing impedances can be conveniently mounted directly underneath the variable condensers in the first and second r. f. stages. The coils L_3 and L_4 in Fig. 1 were wound on Precision Coil Co. r. f. choke coil forms, 20 turns per slot or a total of 80 turns. These were wound with No. 32 DSC wire. A substitute choke can be made of 75 turns of the same sized wire wound single layer on a $\frac{1}{2}$ in. form. The reason for the small gauge wire and

small diameter is to make the field of these coils as small as possible and more important, to get the proper amount of effective resistance. By having a certain amount of resistance in these coils the circuits $L_3 C_3$, and also $L_4 C_4$, do not tune too sharply but have a rather broad resonant peak.

These coils are tuned by small condensers, X-L Variodensers .0005 mfd. maximum, to about 175 or 180 meters, and so at that wavelength offer nearly an infinite impedance. At the higher wavelengths the impedance becomes less and more feed-back is al-

lowed which keeps the regeneration present in each stage constant over the broadcast band. Of course in order to do this the constants of the circuit must be properly proportioned.

The Hammarlund auto-couple transformers have a centertapped winding of 30 turns. Seven of these turns must be removed from the inside part of the primary coil, leaving 8 turns in the equalizing portion of the primary and 15 for the main primary itself. The screw which adjusts the primary coupling should be set so that the outside

(Continued on page 58)

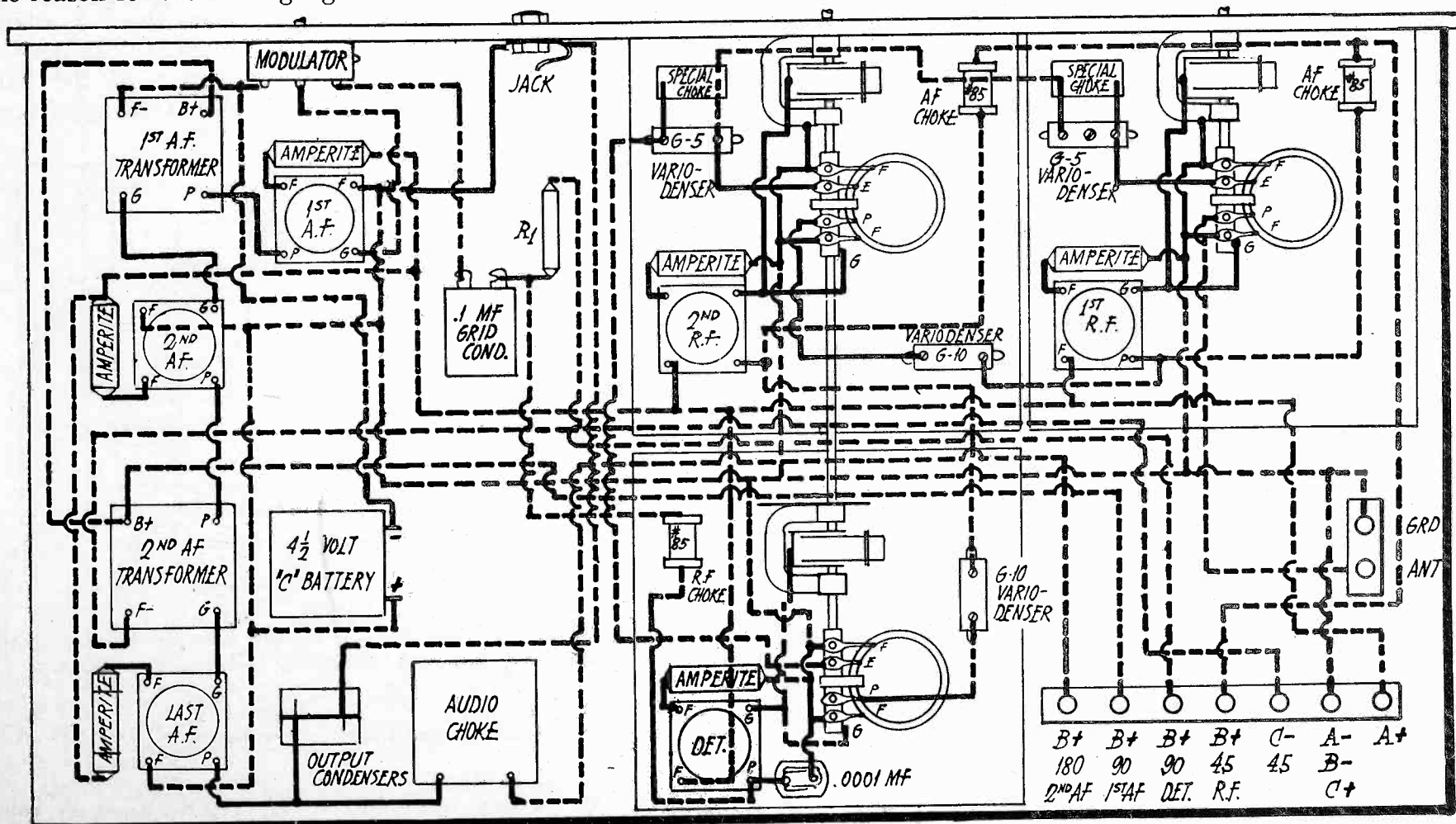

Fig. 4. Pictorial Wiring Diagram of Impedance Equalized Receiver

The Duo

A Two Tube Set Employing A Double-Grid Tube for R. F. and A. F. Amplification

By Harry R. Lubcke

WITH the advent of American quantity production of double-grid vacuum tubes the high per-tube efficiency of European receivers of more or less laboratory nature has become a reality for the broadcast listener. The Duo is a two tube receiver, constructed of readily obtainable standard parts, using a double-grid tube for dual amplification at radio and audio frequencies, and an alkali vapor tube as a regenerative detector. Through the use of efficient apparatus, matched and adjusted for maximum gain per stage, satisfactory loudspeaker operation is obtained; comparing favorably with three and four tube sets

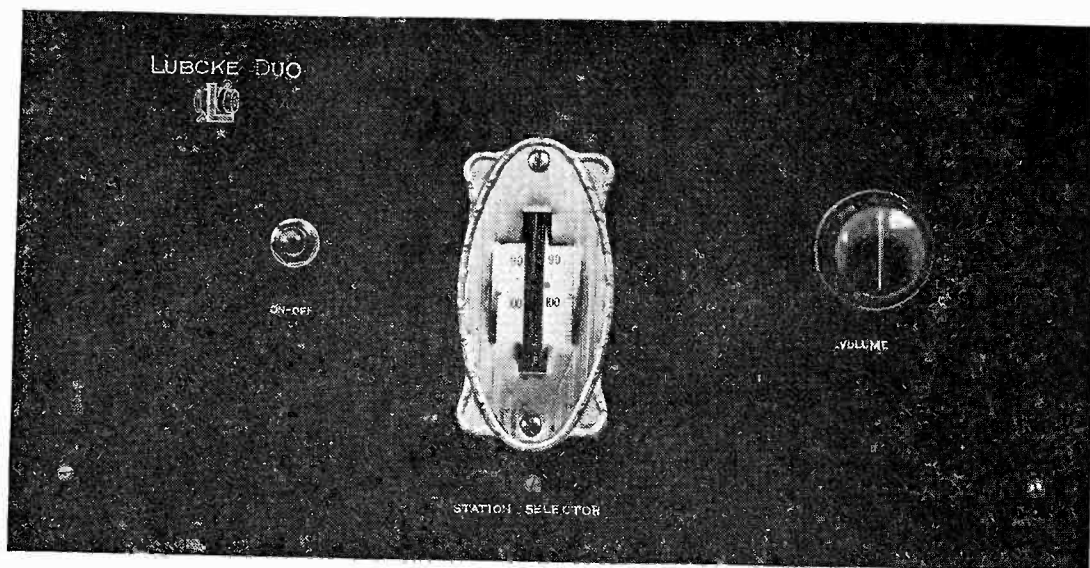

Fig. 1. Panel View of Lubcke Duo

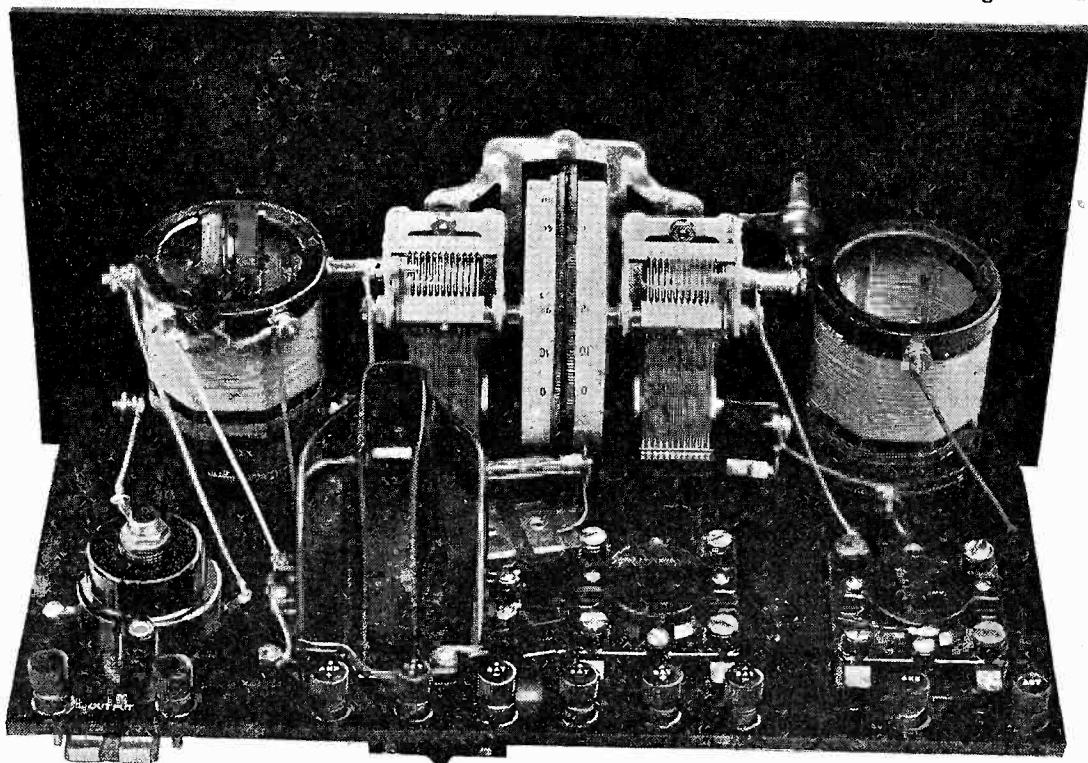

Fig. 2. Rear View of Duo

of conventional design. The receiver operates equally well with batteries or socket-power devices.

Fig. 1 shows the front view of the panel. The main tuning control is the drum dial labeled "station selector," and controls two variable condensers, either together; or separately, when fine adjustment is desired. The second control is the "volume" control which varies the regeneration. The small "on-off" knob on the left is the filament switch, and is not a control in the usual sense of the word.

A Bruno "Unitune" furnishes the r. f. and detector resonant and coupling circuits, being represented by L_1 , L_2 , C_2 , and L_3 , L_4 , C_4 , L_5 , respectively, in Fig. 3; and by the two variable condensers and coils in the rear panel view of Fig. 2. The incoming antenna energy is fed into the r. f. resonant circuit L_2 C_2 by the 10 turn aperiodic primary L_1 . From here it is impressed on the

outer grid of the Van Horne tube V, is amplified, and passed on to the detector resonant circuit L_4 C_4 through coupling coil L_3 . It is detected and regeneratively amplified by the CeCo type "H" special detector C, the audio frequency component flowing through the primary of T_1 , a General Radio 1 to 2.7 audio amplifying transformer; the secondary of which impresses the energy on the inner grid of V. Here it is again amplified and the final audio output delivered from the plate circuit of the Van Horne tube at the terminals so marked.

A Phasatrol Ph, prevents oscillation in the r. f. circuit by shifting the phase of any feedback energy so that it does not reinforce the original impulses. Condenser C_1 bypasses the r. f. energy around the primary of T_1 , as does C_3 around the impedance of the loudspeaker. C_6 is a 1 mfd. Tube bypass con-

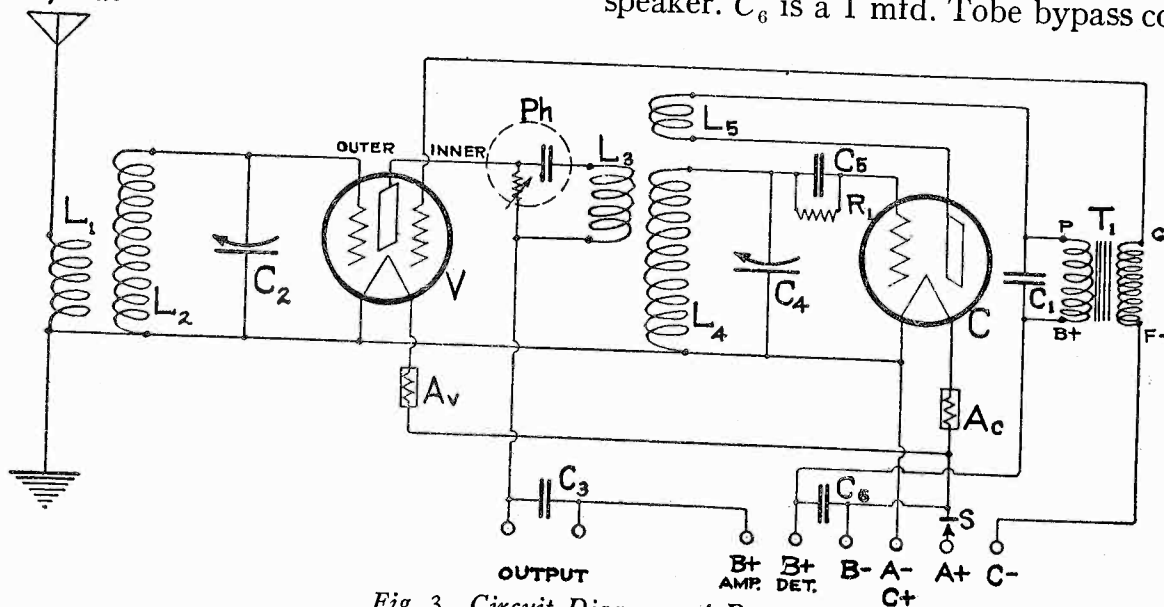

Fig. 3. Circuit Diagram of Duo

- | | | |
|--|----------------------------------|--|
| L_1 10 turns, 2 1/4 in. diam. | C_3 .002 mfd. Electrad Mica. | S Electrad Filament Switch. |
| L_2 60 turns, 2 1/4 in. diam. | C_5 .00025 mfd. Electrad Mica. | 2 Eby UX Sockets. |
| L_3 8 turns, 2 1/4 in. diam. | With grid leak clips. | 10 Binding Posts. |
| L_4 60 turns, 2 1/4 in. diam. | C_6 1 mfd. Tube. | Panel 7 by 14 by 1/8 in. |
| L_5 30 turns, 1 3/8 in. diam. | R_1 2 meg. Tube Loewe Leak. | Sub-panel 7 by 13 by 1/8 in. |
| C_2 .0005 mfd., S. L. F. | Ph Phasatrol. | (Formica) |
| C_4 .0005 mfd. S. L. F. | T_1 1:2.7 G. R. Audio. | Celatsite Wire. |
| (All of above furnished by Model TK Unitune) | AC+AV 1/4 amp. Amperites. | 1 Tapered Knob for Volume Control, 8-32, 6-32, |
| C_1 .001 mfd. Electrad Mica. | V Van Horne Double Grid Tube. | 4-36 Screws and Nuts. |
| | C Ceco H Detector. | |



QUERIES *and* REPLIES



Questions of general interest are published in this department. Questions should be brief, typewritten, or in ink, written on one side of the paper, and should state whether the answer is to be published or personally acknowledged. Where personal answer is desired, a fee of 25c per question, including diagrams, should be sent. If questions require special work, or diagrams, particularly those of factory-built receivers, an extra charge will be made, and correspondents will be notified of the amount of this charge before answer is made.

Kindly publish a diagram of a short wave transmitter, using a Ford spark coil as plate supply, for a 201-A or similar tube.—F. C. D., Delano, Calif.

The circuit for a simple transmitter, using a 6 volt storage battery as source of power, is shown in Fig. 1. The spark

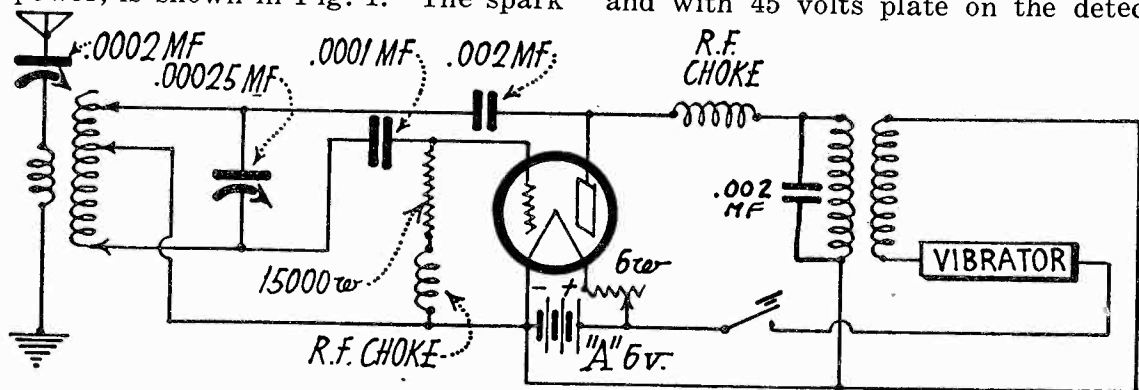

Fig. 1. Simple Hartley Circuit

coil secondary is used to supply the plate voltage, with a fixed condenser across the secondary winding to limit the voltage, and prevent flashing over in the base of the tube. The key is placed in the primary of the spark coil, which receives its power from 6 volt battery lighting the filament of the tube. A simple Hartley circuit is used, with separate antenna tuned circuit, using adjustable coupling between the antenna coil and the oscillator.

Have had considerable trouble in getting the detector of my home made set to work properly. With one stage of audio, I still get only enough volume to work the headphones, and not as much as others are getting from the detector alone. What could be the trouble.—W. B., Bakersfield, Calif.

Lack of sensitivity, in a non-regenerative detector circuit, may be in the use of a wrong size grid leak and grid condenser, or wrong plate voltage. Assuming that the detector tube is a good one, of the 201-A variety, the grid leak should be 2 megohms, and the grid condenser .00025 mfd. If the leak was low in resistance, and was actually 1 megohm or

less, the sensitivity of the tube would be greatly reduced, while if the grid condenser was leaky, and had an internal resistance of only a megohm or so, the same effect would be noticed. To check this, cut out the grid leak and condenser, and with 45 volts plate on the detector,

insert a 4½ volt C battery in the grid return lead, where it connects to the filament. Connect the negative of the C battery towards the grid, and the positive C to the negative of the filament. This will make the tube detect properly, and if the set is still insensitive, the trouble may be in the tube, its socket, or in the B battery supply.

Would like to have a circuit diagram of the Stromberg-Carlson Neutrodyne, which I understand has three stages of shielded, tuned r. f. amplification.—E. E. R., Poughkeepsie, N. Y.

The schematic wiring diagram of the Stromberg-Carlson receiver is shown in Fig. 2. It has three stages of r. f., with two controls, one being a single condenser, and the other a three gang condenser across the r. f. transformer secondaries. The shields are shown in dotted lines, and the values of the condensers and resistances are given wherever possible.

How successful have the superheterodynes having two stages of untuned r. f. amplification ahead of the 1st detector been? I am interested in building this type of receiver, for use with a

loop antenna, and would like to know of the results obtained with them.—G. F. S., Chicago, Ill.

We have not published such a circuit, and doubt the advisability of two stages of untuned r. f. ahead of the 1st detector. Unless the intermediate frequency amplifier and filter circuit was ultra-selective, the receiver would be difficult to operate in a congested locality. Several very successful superheterodynes employing one or more stages of tuned r. f. amplification have been built, and described in these columns. The selectivity obtained with the tuned stages permits operation close to powerful local stations, using either a loop or outdoor antenna.

Am interested in building the 1927 Best Superheterodyne, and wish to ask a few questions. Want to use a loop antenna without three tuning controls. Would this be possible by cutting out the r. f. amplifier tube? Is the negative "A" battery connected to ground? Could a pair of the new double impedance couplers be used in the audio stages? Can the new 200-A detector tube be used in this circuit?—H. W. W., Hastings, Ia.

If the r. f. stage is to be used, with loop antenna, there must be three controls, as the tuning curve of the average loop antenna, and that of the r. f. transformer, have different slopes, and using a two gang condenser would be impractical. By cutting out the r. f. tube, you would have a standard 8 tube superheterodyne, with two tuning controls, whether for antenna or loop operation. The negative A should be connected to ground. The new double impedance couplers can be used in the audio stages, although a three stage audio amplifier will be required when using them. There is sufficient room in the set, however, to accommodate the extra apparatus. The new 200-A tube can be used, by controlling the filament with a 10 ohm rheostat, instead of from the main rheostat

(Continued on page 63)

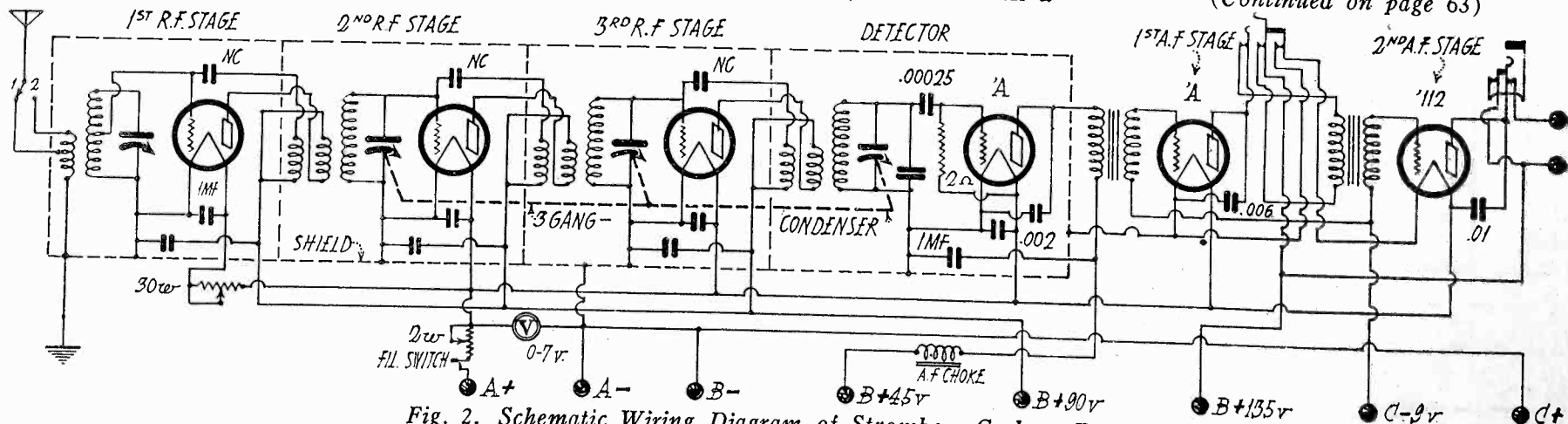
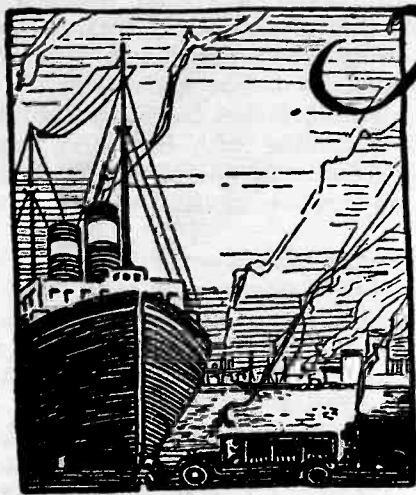

Fig. 2. Schematic Wiring Diagram of Stromberg-Carlson Receiver



R. O. KOCH, *Great Lakes Correspondent*

The COMMERCIAL BRASSPOUNDER

A Department
for the Operator
at Sea *and* Ashore



Edited by P. S. LUCAS

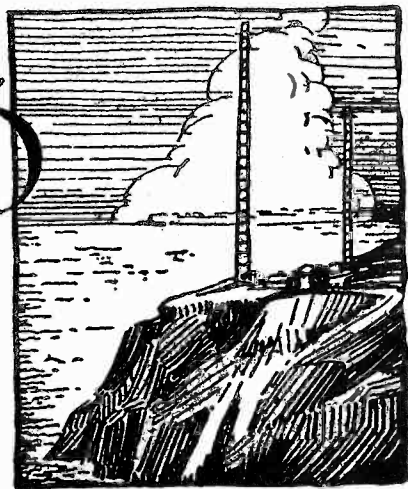

C. WILLIAM RADOS, *Boston Correspondent*

ARE YOU FOND OF QRN?

Last January we ran a short article by Carta McCormick, KDIW, explaining the McCaa band eliminator. Judging from the total lack of reports our esteemed (hw?) readers either are no longer bothered with QRN or are waiting for somebody else to try the stunt out. Or it might be that, as static eliminators in general have always proved to be a bunch of flops, the elimination of this element is impossible, so why fuss with it?

Now, it appears to me that the McCaa device has the proper dope and should prove effective if given a try. It is absurdly simple; if you will turn to your copy of RADIO for January and look at Mr. McCormick's article on page 42 you will notice that the principle of the device is not the elimination of static alone but the elimination of all audio-frequencies other than the particular one you wish to copy. That is, if you are trying to receive signals from a spark station using a spark frequency of 490 cycles per second, you would tighten up on the steel band until you reached the tension at which a 490 cycle note would excite the band into vibration; and this frequency would be the only frequency that could pass over to the next transformer. The same applies to I. C. W. while C. W. would pass at the frequency of the heterodyne of transmitter and detector, being varied by the receiver adjustment.

Mr. McCormick doesn't say what kind of transformers should be used but I can't see that it should make much difference. One extra transformer, an old pair of Baldwin fones, a bunch of little fixed condensers and the band itself make up the total list of parts needed, which isn't much, and would be less than nothing if it knocked QRN out of commission. Give it a try, men. It doesn't take an engineer to understand it; I almost know what I'm talking about, myself.—P. S. L.

Elden Smith, 6BUR of Whittier, has decided to spend the summer around the South Seas, signing on the Yacht Ripple, KFLF. A ¼ K. W. tube, using 500 cycle plate supply is to be operated on both 600 meters and in the 40 meter band.

KFS of the Federal Telegraph Co. gave press report of the progress of the Army Fokker monoplane which successfully flew from San Francisco to Honolulu, June 28-29, 1927. Previous to the flight a message was broadcast from the arc stations at Los Angeles, San Francisco and Portland requesting all ships to listen for the plane's signals and to report its position if sighted. Such reports were received from the *Sonoma*, the *Cleveland*, and the *President Pierce*. These were instrumental in keeping track of the flyers while enroute.

The NSS-NAA press schedule is now being transmitted on 37.4 meters starting at 11:00 P. M., P. S. T. Can be copied beyond the 180th Meridian in summer and as far as Japan in winter.

REGENERATION FOR THE SE 143

By STANLEY WADE, SS SAN GIL

Here's another method of getting better results with the good old S. E. 143 receiver. There's not much work involved, either. Let's hear about your results with it, OMs.

Although there is a tickler on the SE 143 (IP 500) type of receiver, it very seldom gives good regeneration. The tickler on these sets is quite large and is intended primarily to cause the detector tube to oscillate, for the reception of CW signals, rather than for the purpose of obtaining regeneration, for signal amplification. The tickler causes the detector tube to go from a non-regenerative to an oscillating state so quickly that unless the operator has a micrometer wrist, no satisfactory regeneration can be obtained.

Another difficulty experienced with this receiver is the fact that, if the set oscillates satisfactorily on low waves, it usually does not on high waves, and vice versa. Operators sometimes remedy this by having the tickler leads exposed, so that they may be reversed, although this is a rather inefficient and unshipshape procedure.

Now for the remedy of these evils, which will permit fine regeneration on ship waves and good oscillation on both ship waves and long waves. This cure-all contains no new ideas but is rather a grouping of several ideas which have been carried out separately by various operators.

The substitution of a plate variometer in place of the tickler, on the lower waves (400 to 800), and the use of a tickler reversing switch, provides good control of regeneration and oscillation over the entire wavelength range of the receiver. All that is necessary is to invest in a couple anti-capacity switches and a variometer, mount them, hook them up as in the diagram and you'll have an attachment for the receiver that will make you wonder how you managed to get along without it. This means of regeneration control has proven so satisfactory that special control panels, containing the variometer, switches, a detector and two step, have been installed on all T. R. T. ships equipped with IP 500 tuners.

A fairly good sized variometer is needed to make the set function properly on 800. The Amrad basketball type is ideal for this and can usually be picked up for half a dollar at some radio shop dealing in old or job lot equipment. The switches can be Yaxley 6 spring or of a similar type. Jones double pole double throw, push pull, switches might also be bought for a quarter each at the same store as the variometer, and they are very good. Anti-capacity switches improve the appearance and ease of operation of the regenerator unit, although midget double pole, double throw switches can be used in a pinch.

There is also another bit of dope in connection with the handling of an SE 143 which is not known to some operators and which is fine business, and that is the use of the stand-by tuning for 600 rather than the tuned side.

This is accomplished by using the receiver on the untuned side with the secondary switch making contact with switch points 2 and 3 at the same time. Tuning is then done by means of the antenna condenser and the inductive coupling control. The primary condenser can usually be set and all tuning done by changing the coupling. An increase in coupling lowers the wavelength while a loosening of the coupling raises the wavelength. This adjustment provides for 600 tuning while 700 may be tuned with the secondary switch on 3 and a corresponding increase of the primary.

This method of tuning gives much better signals and is nearly as selective as with the tuned secondary. I have found that when using the untuned circuit, the use of a small amount of inductance and a large amount of capacitance in the primary circuit is better than large inductance and small capacitance. This is particularly true when using a break in which puts the transmitter secondary into the receiver primary circuit.

RESULTS WITH THE "A LA BRASSPOUNDER"

By E. F. KEY, S. S. DEPERE

One of the receivers "A La Brasspounder" has been made up here, and here's Mani tnx to Ritz for passing out the dope. They certainly are the goods. Naturally, different parts were used, so here is the dope on this one:

The TRF and detector circuit condensers are .001 mfd. and the regeneration control is a .0005 mfd. The circuit is the same although two steps of transformer coupled AF is used, a filament control jack being placed in the last step so that one or two steps may be used.

Being unable to get Hammarlund coils, the coils were obtained from the ten cent store. They are wound on celluloid with the primary inside the secondary. For 600 meter work these coils are connected in series, and will tune from 500 to 1200; they come three in a kit; two are used for secondaries and the other cut up for primaries and tickler. If Hammarlund coils are used, 75 turns is about right.

The set oscillates very easily, a ten turn tickler is about right for the shorter waves and for the longer waves a 25 coil does the trick.

Following coils are used here, with .001 mfd. condensers across the secondaries and a .0005 mfd. condenser for regeneration control.

R. F. pri.	R. F. sec.	Det. pri.	Det. sec.	Tick	W. L.
10	35	10	35	10	250-500
25	75	25	75	15	500-1200
200	300	200	300	25	1200-4000
300	750	300	750	200	4000-10000

The switching arrangement is not used, mainly because I wrecked a HC set and have plenty of coils to play with.

THE WRECK OF THE STEAMER ANN ARBOR NO. 4

By FERRIS MCKESSON, NOW WDM

This is the first time we have ever run a story about a wreck, although we have been asked for one several times. This will be particularly interesting to the salt water gang, because very few of us know about the conditions met with on the Lakes. Now that we have a starter why can't some of the rest of you who have interesting tales to tell come across with something like this? We can't all have the same experiences, you know, so let's divide up.

Whether you are superstitious or not, here is one February the 13th that proved to be unlucky, for it was the day upon which the ill-fated Ann Arbor No. 4 met her doom.

Clearing Frankfort, Michigan at 8:20 PM on that evening, in the year 1923, the Number 4 started for Kewaunee, Wisconsin, with a cargo of nineteen loaded cars. One car contained Studebaker automobiles, one was full of chloride and the remaining seventeen were filled with coal. The weather was ideal, except for a little snow that was falling with an increasing rapidity, and there was little or no wind or sea. We were soon speeding on our true course, West by South One Half South, never suspecting that on this night our floating home would be called upon to exert all of her fine endurance and experience in heavy weather to bring her crew back to safety, when forty minutes later a heavy westerly gale, quite the nature of a typhoon, sprang up without warning and blew with a velocity of seventy-five miles per hour. I had finished my work but a short time before and having notified the Manitowoc Radio Station the time of our departure from Frankfort, had availed myself of the opportunity of rolling in for the night.

When I awoke, the ship was creaking and cracking due to a heavy coat of ice, and rolling and pitching violently; quite the contrast to my final impressions before going to sleep. Directly under the radio room a car of coal had broken loose and jumped the track and was swaying back and forth, breaking out the steel stanchions that held the upper deck, causing the floor of the radio room to settle a few inches. Things were beginning to get interesting so I immediately proceeded to dress and stepped out into the passenger cabin just in time to hear the OM ordering everyone out on deck.

Every available member of the crew that was not on duty was called out of his warm berth and employed on the car deck to keep the cars from running off the stern, heavy steel jacks that are used to keep the cars from swaying in heavy weather had fallen down and were replaced, turnbuckles and top chains were tightened but in many cases these were broken and could not be replaced; everything on the car deck was an unsightly mess.

The storm kept up with continued fury, and with the increasing hours more and more havoc was being wrought among the cars, many more having been dislodged from the tracks. One gondola of coal had succeeded in tipping over and strewing its contents over the cardeck. The captain, officers, stewards, porters and every available member of the crew, with much danger of personal injury, were down among the cars, dumping the coal cars and endeavoring to dislodge them from the tracks, for by doing this they found they could keep the cars from sliding off over the stern. The car of automobiles had already slid off and found a final resting place somewhere in the blue waters of Lake Michigan.

The officers had long since lost their bearing but still retained their knowledge of the general direction in which we were traveling and hoped to make the west shore of the lake where they would have put her on the beach and scuttled her. If the cargo in the

forward end had not shifted aft we might have successfully nosed our way to the west shore, but with our stern down and our bow up, no other way was open except to turn around and run with the sea. This was done with serious damage to the ship, as more stanchions gave away and the cabin floor settled about a foot. A few minutes later I saw the lights flicker and grow dim, and had thoughts of a flooded boiler room. I did not dare leave the radio room but after seeing the lights come back to normal I immediately went in search of the Captain, and found him at last, working shoulder to shoulder with deckhands, porters and crew. I told him about the flickering lights and he came to the radio room with me.

It was then 4:50 AM on St. Valentine's Day. I listened in for a few seconds until the Frankfort Station had finished his message to the Manitowoc Station, and before WMW had time to acknowledge it I broke in with the well known distress signal. WFK, Frankfort acknowledged it and I proceeded with the captain's message, giving him some of the details of our predicament. At 6:00 AM I again started up and reported that we were riding easily and running with the sea and that the steward was passing out hot coffee to the crew. Later I found out that I had caused much anxiety among the operators on the Lakes, as the last they heard from me was at 5:00 AM and many thought we had gone down. The other three sister ships of the fleet were laying on the west shore awaiting weather; the Number 3 and Number 6 were inside the breakwater at Manitowoc, Wisconsin and the Number 5 was at Manistique, Michigan. On all three boats a steady watch was kept by the operator should they receive orders to come to our assistance, but we were lost and could give them no position.

The Frankfort station with C. O. Slyfield on watch told me that in the last hour my signals were much stronger and that we must be close upon them. I heard the Manistique Naval Station tell Frankfort that my signals were strong and the operator thought we were near Manistique. I reported this to the OM who was, at the time, in the pilothouse with the first officer, and went back to the radio room. Then I remembered that the boys at WFK had once built a direction finding compass with which to experiment and give us our approximate bearings, and, although I knew it had long since been dismantled, I asked the operator to hook it up again and try to give us a QTE. I was told to stand by for five minutes, which I did, noting that it was then 7:00 AM. At 7:05 I tested for a bearing but was told that we were so close it was impossible to get a correct check.

I again reported to the OM in the pilothouse and a few minutes later the first officer held up his hand for silence. Amidst the cracking and creaking of the ice on the ship we heard the fog horn at Frankfort. "A point and a half off the starboard bow," he sang out, and we squared away the best we could. The members of the crew also knew we were nearing land as the second officer, a man who has spent his life on the water, had noted that the water was changing color and had remarked that we were nearing shore.

A short time later we were pounding against the outer end of the South Pier with every wave. As we still had steam and electric power I was told to report that we were up against the pier and breaking to pieces. This was the last message that was sent, for we immediately began to settle and the engine room and boiler room were flooded. The men in the engine room and firehole, having stuck to their posts like the heroes they were, climbed out of the engine room hatch and through the emergency fire escape that leads from the firehole to the upper deck.

The coast guards tried to launch a surf

boat but failed, as it was soon smashed to pieces against the ice and heavy seas. So they made their way along the North pier and would have shot us a line and taken us off one by one in the breeches buoy, had not the Captain, by motioning with his hand, made it clear that we were in no immediate danger and would stay aboard until the storm had subsided.

With all wireless communication gone things began to get lonesome for me so I thought of my buzzer, hooked it up to the tuner and talked with the operator at WFK. This diversion afforded amusement but not enough exercise, so I gave it up and went out on deck where I could keep warm by walking. The stewards prepared a lunch for us and about noon three U. S. coast guards made their way out to the ship by crawling along the icy pier, taking chances of being swept off by the waves that came clear over the pier. They told us that the marine superintendent had given orders that we were to leave the ship, which was good news for me. Many times these men had to hang onto chunks of ice to save themselves from being swept off their feet, and at times I could not see them at all for the sea would sweep clear over them and bury them with water. The thought of having to do that myself in a few minutes was not so pleasant, you can bet.

Shortly after noon we tied ropes around ourselves and left the ship in gangs of ten or twelve, much in the same manner as mountain climbers who tie ropes around each other so that should one have the misfortune to fall the rest would save him. None of us had this misfortune, however, so we made it ashore without mishap. A few frozen fingers, toes and ears were the only marks of hardship, and all of us were happy to be on land again. The marine superintendent greeted us as we came down the pier, shaking hands all around and saying that never in all his life had he been so glad to see a bunch of fellows as those of the Str. Ann Harbor No. 4.

Nine o'clock that evening found many of us younger fellows at the St. Valentine's Masquerade Ball, none the worse for our experience and having the time of our lives. The terrible night we had gone through was like a horrible nightmare, forgotten with the light of day.

Never in all my life have I seen men and boys that would have met their death like the crew of the Ann Harbor No. 4, and if ever again I hear an SOS, here's hoping and praying that the Master of the distressed steamer will have a crew as heroic as the men we had aboard that memorable trip.

SOME RECENT QSTs

As receiver by FRED V. TRUEBLOOD
KIPJ

From VBT Halifax, Nova Scotia; April 18, 1927. All ships: Canadian Govt. vessel call sign VCQ now maintaining ice patrol Cabot Straits. She broadcasts ice conditions, etc. EST 8 AM and PM, 600 meters spark, and 8:30 AM and PM 1621 meters ICW.

From WNU, May 31, 1927. All ships and stations: Effective June 1st radio station call letters UF at Barrios, Guatemala will observe following ship schedules using a transmitting wave of 2100 meters and 90th meridian time for all schedules. 7:15 AM, 8:15 AM, 9 AM, 10:20 AM, 11:15 AM, 12:30 PM, 1:30 PM, 2:30 PM, 3:20 PM, 4:20 PM, 5:10 PM, 6:40 PM, 7:20 PM, 8:45 PM, 9:45 PM and 10:30 PM. Barrios will call CQ for ships to answer on 600 meters CW or ICW and afterwards for answer on 2200 or 2400 meters CW. A transmitting wave of 600 meters will be used to work ships off schedule.

(Continued on page 50)

With the Amateur Operators

An 80-Meter Phone Transmitter

By A. BINNEWAY, JR.

Nothing can put over an idea or bring out the fine points in friendly chatter better than just plain "talk." "Fome communication is all right for short distances," someone has said, "but give me code for DX." Fortunately, good DX can also be done in the 80 meter fone band which is alive with voices these evenings. The 80 meter fone transmitter here described is both simple and inexpensive.

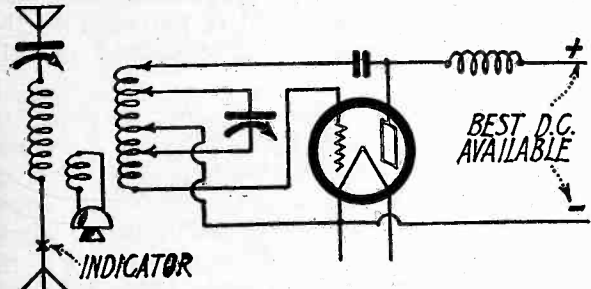

Fig. 1. Circuit Diagram of 80-Meter Phone Transmitter

The circuit diagram is shown in Fig. 1. As may be seen in the illustration, the inductances are rather small in diameter and are space-wound on 2½ in. cardboard tubing. Celluloid strips, 1 in. wide, are spaced about the circumference, the wire is wound over these and is securely held in place by painting with collodion. Fixed coupling is used and 2 in. is about the right distance between coils. The correct coupling for the particular arrangement may be determined, after which the wire may be cemented in place.

The graduated tubing for the microphone loop is smaller in diameter and slides inside the other. The graduations are spaced on a sheet of paper, are numbered if desired, and this paper is then pasted about the circumference of the tubing. It is necessary to tap the main inductance at every turn for proper adjustment. This is done by soldering pieces of sheet copper in place, in three rows, the taps for consecutive turns being in adjacent rows.

The coil supports are cut to conform to the circumference of the tubing and the RCA condensers are also mounted on these uprights. The sockets consist of spring brass pieces which are soldered to the tube pins, and two porcelain telephone fuse holders, as already described in RADIO. The choke consists of about 250 turns of about No. 26 wire on a piece of 2 in. tubing.

The shunt condenser may be constructed from a good receiving condenser which should be double spaced. Very good (.001 mfd.) condensers are available on the market and these are readily double-spaced. Remove the rotor and stator and bend every other plate of the latter so it will clear the brass support. Then, using a small tool such as a dial screwdriver drive out the proper plates. Hold the rotor and stator over the edge of the bench so this may be done.

The value of the grid and plate stopping condensers is not critical and may have any value such as .001 mfd. The smaller condensers will give a steadier wave but very small ones will not allow proper oscillation. The plate supply should of course be well-filtered so that objectional frequencies, found in rectified plate supplies, will not also modulate the wave.

To operate, set the plate clip at the "far" end, the filament clip between, and shunt the condenser across a few turns on either side of the latter. Adjust for steady output with small plate current and maximum radiation at the particular wave. Insert the loop so that it is near the grid end of the inductance. There will be some position near the grid

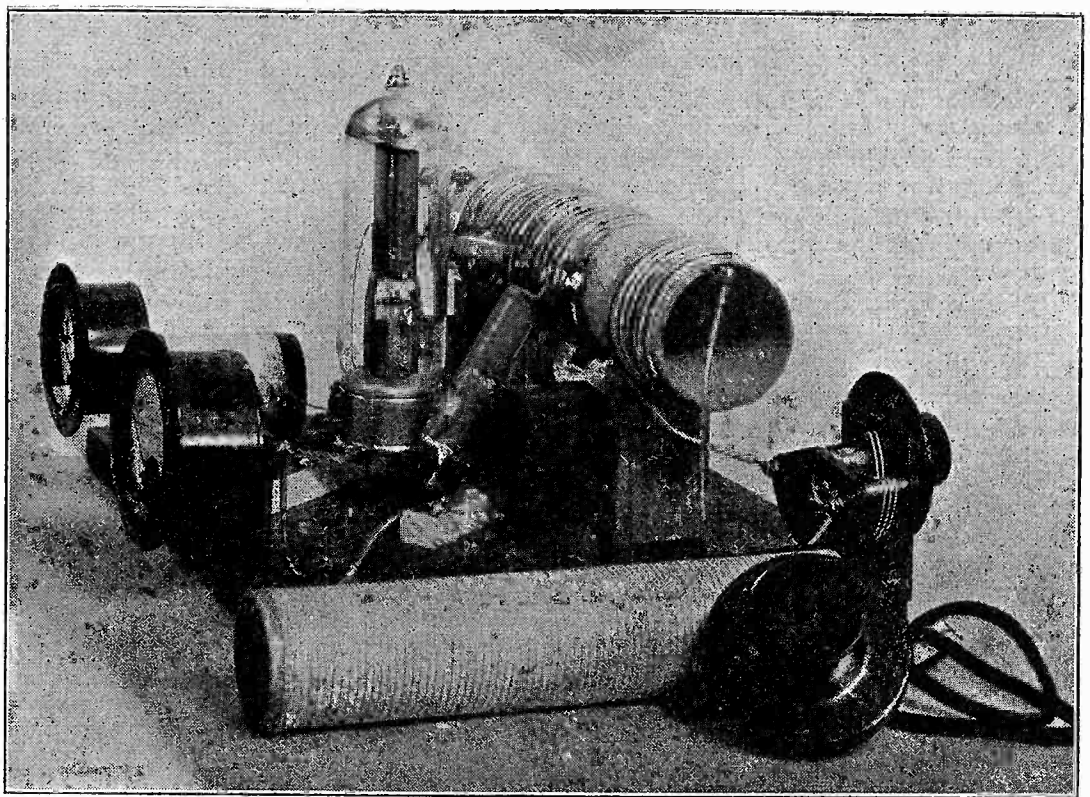

Phone Transmitter Used by Author

end or between this end and the antenna coil, at which best modulation will be secured. This position may be determined experimentally and the loop may be returned to the correct position by noting the graduation opposite the end of the tubing. A loop of about 2 turns is about the correct size (too many may cause heating of the microphone). When it is inserted, the adjustments are changed somewhat and the filament clip, etc., should be slightly readjusted. Ordinarily, the loop should be removed when using code; a key provided with a shorting switch will allow the use of both.

As the plate voltage is applied to the tube during the entire conversation, the plate current should be kept small and this means low plate voltage if the plate area is small, usually.

This type of modulation is best adapted to low power transmitters and requires a minimum of apparatus. For these reasons, it will work very well with the ordinary 7½ watt installation.

to cause the plate current to reach saturation. This is indicated when an increase in plate voltage fails to increase the plate current shown by the milliammeter in the plate circuit.

These readings are plotted as a curve which determines the filament current corresponding to the steepest part of the curve. With the filament voltage set to give this critical value, the oscillator is started and its antenna current allowed to pass through the tube filament. This r. f. current has the same effect on the filament as a d. c. current would have, heating it and thus raising the plate current.

The plotted curve tells the total filament current *A*. The ammeter shows the d. c. component *D*. By subtracting *D* from *A*, the remainder is the r. f. current *F*. Accuracy in measurement requires the presence of the r. f. chokes as shown in the circuit.

WHY TRANSMITTER TUBES GO WEST

By JENNINGS B. DOW

The two common causes of tube failure, aside from the catastrophe of excessive filament current, are (1) failure to meet the required conditions for oscillation and (2) blocking. These will be considered in order.

In the simplest form of reversed feed-back or tuned plate circuit oscillator the condition for oscillation is expressed by the equation.

$$\frac{\mu ML}{C} \geq Rr_p \dots \dots \dots (1)$$

where, μ = plate amplification factor.
 M = mutual inductance between tuned plate circuit and grid circuit.
 L = effective inductance in plate circuit.
 C = effective capacity in plate circuit
 R = effective resistance in tuned plate circuit (includes equivalent antenna resistance).
 r_p = internal plate resistance.
 \geq means "must be equal to, or to be greater than."

This equation was derived by analytical methods and assumes no grid to filament conductance and neglects regeneration due to grid-plate capacity. It shows that by altering M , L , C or R during adjustments of the circuit, the left side of the equation may be

MEASURING SMALL R. F. CURRENTS

By GEORGE B. HART

As the average antenna has a relatively high resistance, the measurement of small r. f. currents in it is difficult with the usual hot wire or thermo-coupled meter. Fig. 1 shows a method whereby this may be accomplished even at very short wavelengths. With this method it is possible to measure 0.1 milliamperes.

The method depends upon the current's effect on the plate of a '99 tube in the circuit. First take a series of readings of the plate current for different value of filament current, the plate voltage being high enough

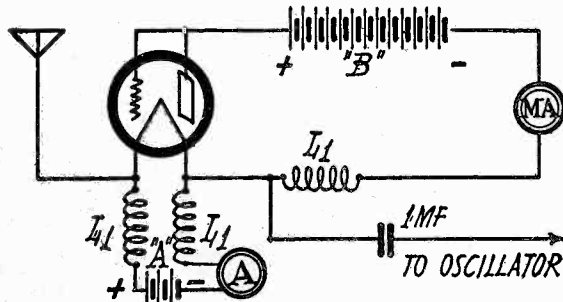

Circuit Diagram for R. F. Current Meter

come less than the right side in which case, the conditions for oscillation will not be satisfied.

A similarly descriptive equation for the tuned-plate tuned-grid circuit is given in equation (2).

$$\frac{L}{C} (\mu - 1) \geq Rr_p \dots \dots \dots (2)$$

Now consider what happens when the tube stops oscillating. Assume any circuit in which a grid leak is employed for biasing the grid at a negative potential. Fig. 1 shows a typical plate-current plate-voltage diagram. This diagram assumes a 1200 volt plate supply and a grid leak of such resistance that when the tube is oscillating, the average rectified grid current times the leak resistance (*RI* drop) maintains the grid at an average potential of 100 volts negative. The steady plate current with such a grid potential would be about 160 milli-amperes as shown. Since the tube is assumed to be oscillating, this steady plate current does not exist and the actual plate current indicated by the plate milli-ammeter is an average one of about 250 milli-amperes as shown by point *B*. The diagram assumes a straight path of operation *CD*. For an actual case, the path would be curved.

If the tube suddenly stopped oscillating, the high frequency alternating current in the tuned plate circuit would become zero in value. No alternating potential would be induced into the

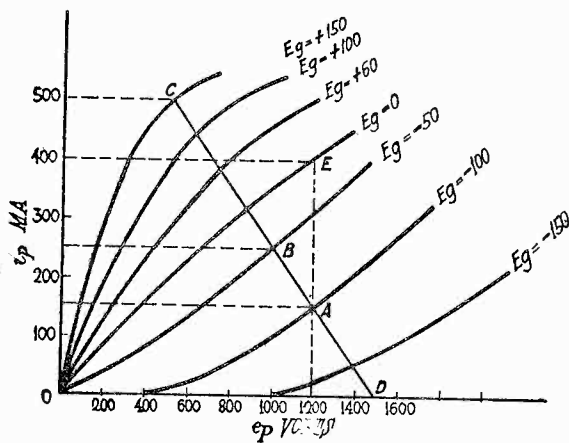

Fig. 1. Typical Plate-Current Grid-Voltage Diagram.

grid coil, consequently the grid current would cease to exist. The grid leak could no longer maintain the grid at 100 volts negative. As a result, the grid voltage would fall to a steady value of zero, and with 1200 volts on the plate, the plate current would rise to point *E* or 400 milli-amperes. Since the power lost as heat in the tube is a function of the square of the current, almost three times as much heat would be generated. Unless the plate voltage were quickly cut off, the plate might get hot enough to damage the tube. The

greatest danger in overheating the plate lies not in the damage through heat alone, but in the effect of secondary emission. When a plate gets white hot, it emits electrons which further increase the plate current. Thus, a vicious cycle ensues which quickly destroys the tube.

Blocking takes place when the tube stops oscillating, not through failure to satisfy the conditions for oscillation, but owing to the fact that the grid potential locks-in at a certain high fixed positive value. This locking-in prevents further alternating grid potentials and the tube stops oscillating. Blocking results from using a leak having too much resistance while simultaneously attempting to force the output by too much grid-plate coupling and high plate voltage. The phenomenon is best illustrated by means of a diagram. Fig. 2 shows a grid-current grid-voltage diagram obtained by using positive grid potential considerably in excess of those ordinarily used in plotting such a characteristic. In collecting data for a diagram of this kind, the plate voltage is fixed. Readings of grid current are taken for various applied grid voltages. It may well be pointed out that an oscillographic method of obtaining the readings is necessary owing to the high plate and grid currents which coexist with the large positive grid potentials.

It will be noted that the grid current actually reverses at *A* so that between the points *A* and *E*, the current through the grid leak is in a reversed direction. In this region the leak tends to bias the grid positively. Most transmitting grid leaks are either themselves inductive or are fitted with radio frequency chokes so that the leak current exists as an average rectified value. Reference to Fig. 2 will show that the average grid potential resulting from the *RI* drop across the leak may be either negative as it normally should be, or positive in the case of excessive grid excitation.

This diagram indicates that if the grid attained a potential greater than 600 volts positive, the average bias would be positive. The mischievous reversal of grid current is responsible for blocking and it will be considered in some detail.

The portion of the curve *AB* is unstable and portion *BE* is stable. To illustrate, assume that through excessive coupling of grid and plate circuits, the average grid voltage became positive. Along *AB* any increase in grid current through the leak means an increase in grid potential,—an increase in grid potential results in a further increase in grid current. Once the average grid potential is positive and the instantaneous grid potential exceeds that corresponding to point *A*, the grid potential will continue to build up in a positive direction until a stable condition is reached at *C*.

As a matter of fact, the grid potential actually jumps from that corresponding to *D*

to that corresponding to *C* because of the instability along *AB* and because, when the instantaneous grid current has a value *B*, the current through the leak is such as to give the grid a potential much in excess of that corresponding to *B*. For example, if the leak were non-inductive the instantaneous current *B* would give the grid a potential of about 1200 volts. On the portion of the curve *BE*, an increase in grid current requires a decrease in grid voltage and any decrease in grid current requires an increase in grid voltage.

Stability follows at *C* where the *RI* drop in the leak assumes a steady value equal to the grid potential which has been reached in the building up process. Since the grid potential becomes fixed, the tube stops oscillating, and with this high steady positive potential on the grid, the high resulting plate current quickly destroys the tube.

To prevent blocking it is only necessary to use a grid leak such that the point *C* cannot lie on the stable portion of the curve that is, by using a grid leak having a resistance equal to or less than that defined by the angle whose tangent is *R₂*. Leak *R₁* has too much resistance and blocking is very liable to result as explained.

It is recognized that most experimenters do not have sufficient data on their apparatus to determine in advance the proximity of a tube failure resulting from either of the two causes just described. However, by understanding what happens, it is possible to anticipate the likely results of certain adjustments and in a measure guard against these very commonly used methods of destroying tubes.

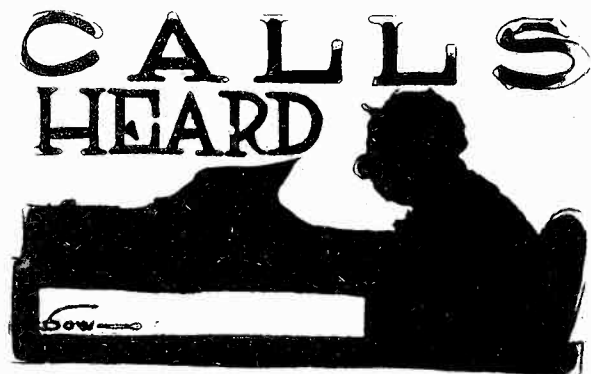

By nu-lve, John E. Reilly, 148 Highland Ave., Bridgeport, Conn.

40 METERS—6adm, 6alg, 6bau, 6ben, 6ben, 6bzf, 6ciw, 6cmg, 6dau, 6hb, 6hu, 6ju, 6nw, 6ob, 6or, 7eg, 7it, 7jf, 7ny, 7vq, 7xf, nc-1ac, nc-1ax, nc-1dj, nc-2bb, nc-2bg, nc-2fo, nc-3adn, nc-3da, nc-3fu, nc-3gj, nc-3mv, nc-3nj, nc-4bb, nc-4dp, nc-4dq, nc-4dy, nc-5hp, nc-9bz, nc-9cd, nl-2t, nm-1j, nm-1k, nm-1n, nm-9a, nn-m3y, nq-2cf, nq-8kp, nr-2fg, nz-ez5, ei-1gw, ep-3fz, eg-2by, eg-5xy, se-1fg, avms, av7, ca, cbz, cgw, dcz, d8q, fw, glky, glq, hjg, jh, jv, kdel, kgbb, lfg, lpw, lpz, lpl, naah, nam, nfv, nidk, npg, nxy, rxy, sjb, voq, wav, wax, whv, wnp, wns, wnbt, wwu, wvz, wyj, wyfi, zoxk.

20 METERS—4bl, 4hx, 4io, 4li, 4mi, 5amo, 6ea, 9acl, 9aex, 9aht, 9alm, 9bjp, 9cet, 9cnc, 9csb, 9cxl, 9dij, 9cxx, 9dkc, 9dlz, 9ef, 9ein, 9ekn, 9es, 9ne, 9nu, nc-1ae, nc-3gg, nc-3jm, nc-4du, eg-5hs. 5 watts on 40 meters. Always glad to QSR or chew the rag. All QSL's answered.

By E. O. Schwerdtfeger, on "SS Margaret Dollar" enroute from Pacific Coast of Guatemala to Jamaica, W. I.

40 METER BAND—1ai, 1aqt, 1atr, 1awm, 1ccz, 1cgc, 1ckp, 1xm, 2abe, 2agn, 2aiw, 2amj, 2aqc, 2atc, 2avw, 2awq, 2bgj, 2cex, 2cfx, 2crb, 2cuq, 2cvj, 2di, 2eg, 2pp, 2rs, 2ty, 2uo, 2vd, 2vm, 2wp, 3aid, 3bjq, 3in, 4ec, 4ll, 4ns, 5ada, 5akn, 5atf, 5auz, 5awh, 5di, 5mx, 5ux, 6bhz, 6bsd, 6nw, 8adj, 8air, 8alu, 8bbs, 8brf, 8bun, 8bzx, 8cau, 8cc, 8cwb, 8djp, 8lt, 8rc, 8wo, 9ak, 9bdg, 9beq, 9bnv, 9bqc, 9cjh, 9cya, 9cym, 9dlx, 9dng, 9ffo, 9gj, 9lz, 9uo, np-4bm, nq-2mk.

20 METER BAND—1rw, 2ahm, 2awq, 2bck, 2px, 2xab, 2xg, 2xt, 4qy, 8aj, 8bx, 8dds, 9bqc, 9dkc, 9dro, 9eag, nc-1ar, nc-3cs.

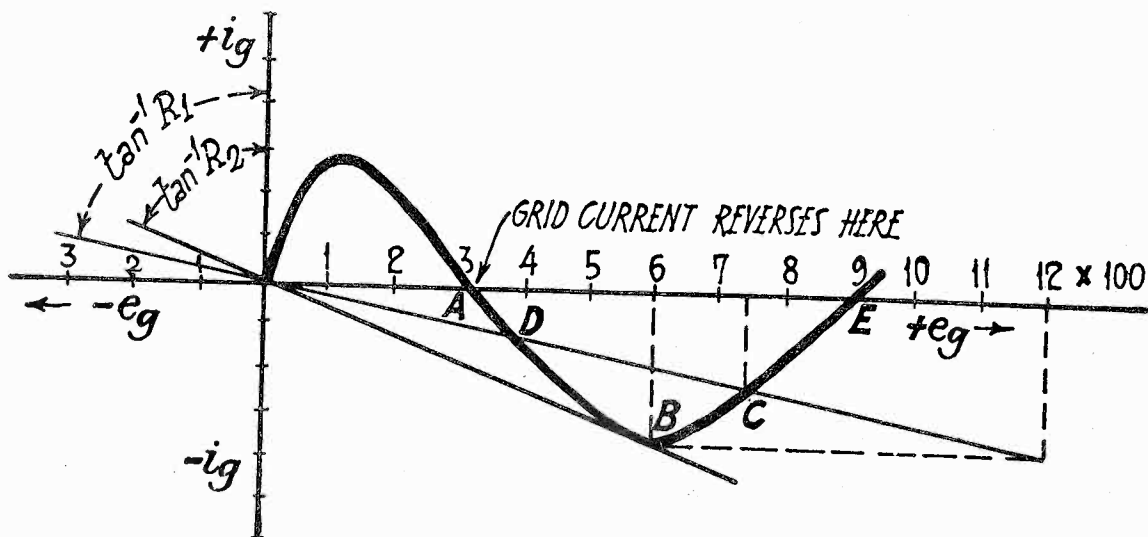
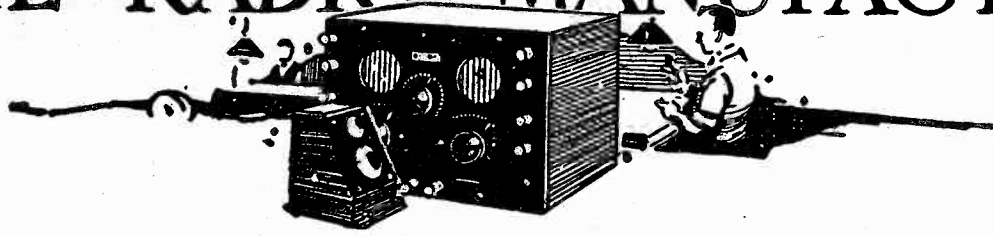
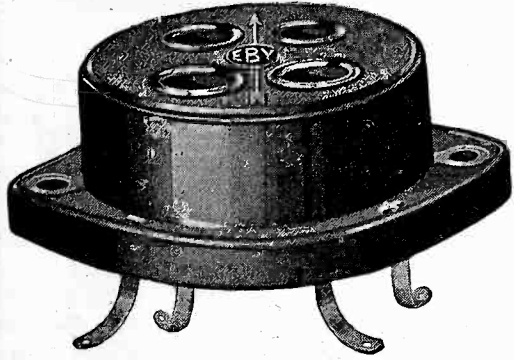

Fig. 2. Effect of Excessively Positive Grid.

FROM THE RADIO MANUFACTURERS



The new Eby socket has 3-point wiping contacts which extend along the length of the tube prong and project from the bottom of the socket so that they may be brought down through a large hole in the sub-panel and thus permit concealed wiring. Two mounting screws hold it securely in place either



above or below on a bakelite, metal or wood panel. Its upper round portion is of the same diameter as the tube base, the rounded portions of the bakelite being polished and the flat portions finished in a new stipple effect.

Aerovox "Pyrohm" resistances are made of resistance wire, wound on a refractory tube, and coated with a porcelain enamel which thoroughly covers and protects the wire from moisture, oxidation and mechanical injury. The wire, tube, and enamel have the same coefficient of expansion, which allows the unit to be used under heavy loads without displacement or injury to the wire.



Resistance units 2 in. long are rated to 20 watts; the 4 in. type, 40 watts; and the 6 in. length. They are manufactured in all usual values from 500 to 50,000 ohms, with intermediate taps if required.

The Electrad socket antenna is screwed into an electric light socket so as to utilize the house wiring as a radio

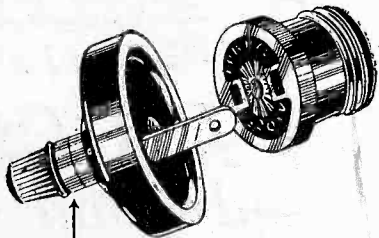

WIRE FROM HERE TO AERIAL TERMINAL ON RECEIVER

aerial. It is made of bakelite, is neat in design and safe, being approved by the Underwriters' Laboratories.

The De Jur lightning arrester employs a special air gap such as is used in commercial practice for protection

against fire and lightning hazards. It is housed in a moulded high-heat insulating material and is weather-proof so

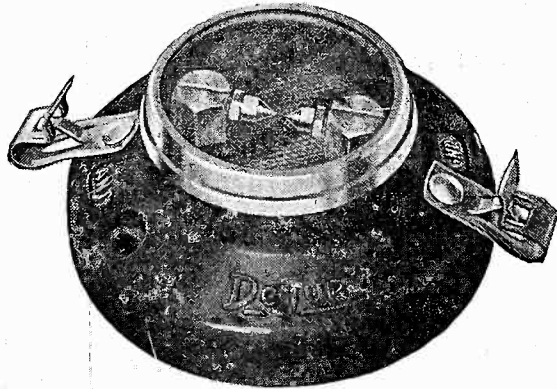

that it can be installed outdoors or indoors. This device has the approval of the Underwriters' Laboratories.

The Electrad lightning arrester has been improved with a high-proofed paraffine waxing. It operates on the air-gap principle and is completely sealed

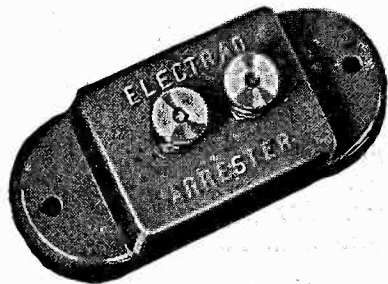

and moisture-proof in a glazed porcelain case. It is listed by the National Board of Fire Underwriters. One model is made for indoor use and another for outdoor.

The Hoyt rotary meter is a combined milliammeter and voltmeter of the mov-

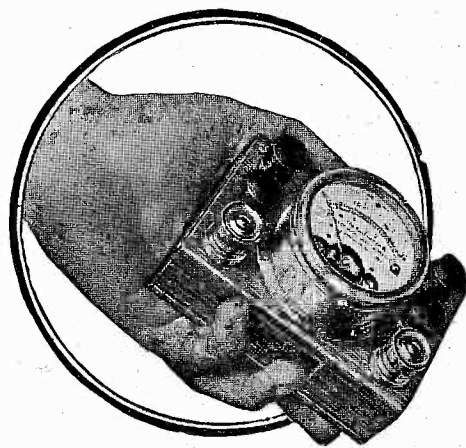

ing coil type. As a current meter it has three ranges: 0-15 milliamperes, 0-75

milliamperes and 0-7.5 amperes. As a voltmeter it has two ranges: 0-7.5 volts and 0-150 volts. These ranges will handle practically any electrical test to be made on a battery-operated receiver. It has high internal resistance and is small in size.

The Continental "Uni-Switch" is designed for automatically turning on or off the "B" battery eliminator as the

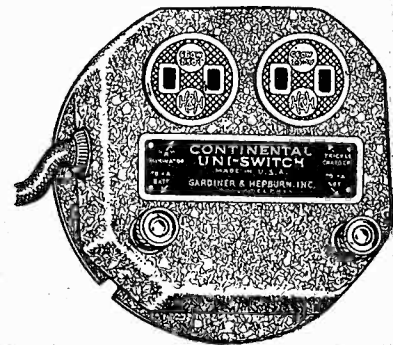

filament current is turned on or off. It likewise throws off or on the trickle-charger.

Polymet resistors are designed for use in power amplifiers, "B" eliminators, or anywhere that a fixed resistance of high

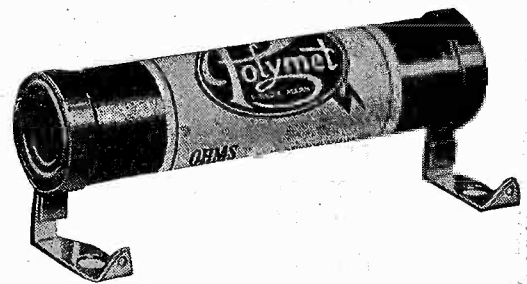

current carrying capacity is needed. The resistance values vary from 750 to 100,000 ohms at from 10 to 20 watts dissipation. The elements are wire wound.

The Tyrman vernier drum consists of two 5½ in. bakelite drums and a heavy-gear vernier which are connected to the condensers on either side by a durable shaft. The vernier gear has a flexible bearing and is kept in mesh with the drum gear by means of a spiral spring. This eliminates back-lash and gives a smooth action. Its fine appearance is further enhanced by an etched bronze escutcheon plate which frames the drums and verniers on the front panel. Concentricity is assured by new type of clutch. Provisions are made for single and double control tuning.

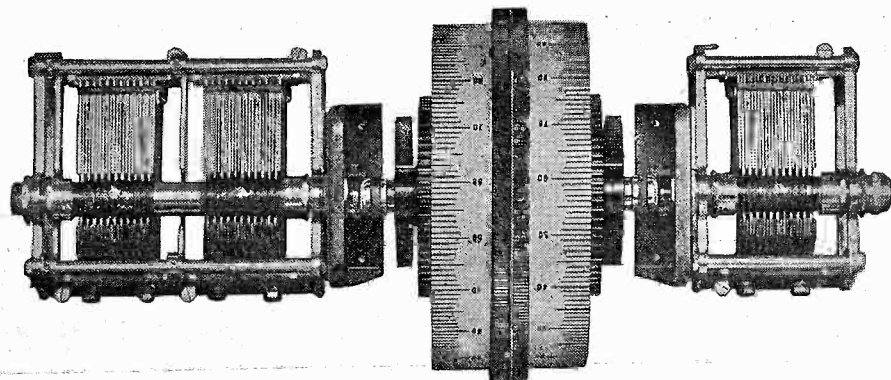

With the New Infradyne Foundation Unit "Front End" and Cabinet You Can Convert Your Set Into a 1928 Model

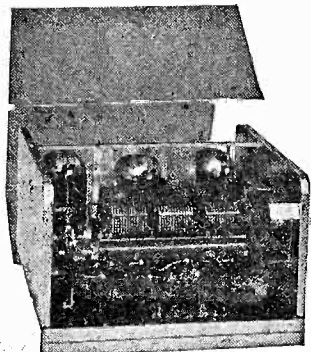

R. F. AMPLIFIER
 Three gang condenser.
 Shielded stages.
 Shielded case.
 Three tube sockets.
 Complete \$55.00
 Antenna Compensator
 included with each amplifier.

The success of the new Infradyne depends on a properly constructed and balanced radio frequency amplifier. The new "front end" for the 1928 Infradyne, as the picture shows, is a complete unit, factory built, tested and wired. It gives you "peak" efficiency over the entire wave band. This amplifier, the new foundation unit and the new copper cabinet are all that is needed to make a 1928 Infradyne out of last years model. Improve your set now.

INDIVIDUAL PARTS for the Model "DX" 1928 Infradyne

A complete kit of all the minor parts, switches, jacks, wiring material, charts, condensers, control panel, rheostats, leaks, connectors, etc., for the 1928 Infradyne as described in this issue..... **\$52⁰⁰**

A Copper Cabinet by Remler for housing the entire receiver. Measures only 26 inches long and 11 inches deep. Beautifully finished in lacquered crystalline **\$15⁰⁰**
 (Hardwood baseboard included at this price)

Remler Drum Dials for the Infradyne or any other receiver. Illuminated from the rear. Price, right or left hand drive, with light..... **\$4⁵⁰**

INFRADYNE AMPLIFIER — The heart of the Infradyne. The now famous Sargent - Rayment 3,200,000 cycle amplifier in copper case..... **\$27⁵⁰**

REMLER 3-in-line Condensers for the Infradyne or r. f. circuits. Equipped with trimmers. Twin rotor type **\$15⁰⁰**

Single REMLER Twin Rotor Condenser with 360 degree dial rotation **\$5⁰⁰**
 (Either S. L. Wavelength or S. L. Frequency.)

Complete parts—foundation kit, radio frequency amplifier, cabinet and baseboard for making a 1928 Infradyne out of your old set..... **\$122⁰⁰**

Keep your meter, Infradyne amplifier and audio transformers.

DELIVERIES NOW BEING MADE

Order your new Infradyne parts now. The demand is heavy. Insure early delivery by telegraphing your order. C. O. D. shipments accepted if half cash sent with order.

We rebuild Infradynes. We repair and assemble sets. Write for our prices. They are reasonable.

RADIO SERVICE CO.

357 TWELFTH STREET, OAKLAND, CALIFORNIA

BRACH Storm King LIGHTNING ARRESTER



Over 2,000,000 Radios are Now Protected by Brach Arresters

Price Only **\$1**

Like all Brach Arresters the Storm King is backed by our

\$100 INSURANCE GUARANTY

Electrify your Radio with the Wonderful **BRACH**

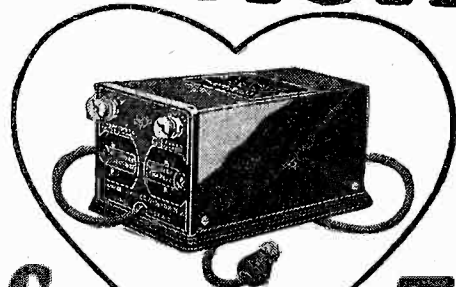

CONTROLIT
 THE HEART OF THE POWER PLANT

Over 75,000 used within First Four Months

L.S. BRACH MFG. CO.

MEMBER **RMA**
 NEWARK, N. J. TORONTO, CAN.

the CROSLLEY "Bandbox"

and other new radio reception equipment
for the complete enjoyment of the 1927-28 radio season



Recent court decisions now greatly clarify radio patent situation.

Ever since Crosley entered the radio field their methods and developments have created a leading place for Crosley radio receivers. And now—completely available to Crosley—and amplifying Crosley supremacy in fullest measure, are the enormous resources, discoveries and ideas, embodied in patents of the Radio Corporation of America, The Westinghouse Co., The General Electric Co., and The American Telephone and Telegraph Co., The Hazeltine Corporation and the Latour Corporation—under which Crosley is now licensed to manufacture. No wonder the new Crosley receivers are in the forefront, their amazing efficiency acknowledged and demanded by that section of the radio trade which insists on the latest and best at all times.

THE "BANDBOX"

It is a new 6 tube set of astonishing sensitiveness. Many exceptional features commend the "Bandbox." The metal outside case, 'tho keeping out strong local signals effectually enough, did not fully satisfy Crosley ideals of fine radio reception. Signals must be kept in order *inside the set.*



TILT-TABLE MUSICONE
\$27.50

Although Musicones improve the reception of any radio set they are perfect affinities in finish, beauty and reproductive effectiveness for Crosley Radios. A new model built in the form of a Colonial Tilt-table and finished in brown mahogany stands 3 feet high.

12-inch Ultra Musicone
\$9.75

16-inch Super Musicone
\$12.75



Coils and condensers are like families living in a row of houses with no fences between. The children run around the yards; they meet, mix it up, quarrel and squabble. No harmony.

Magnetic and electric fields are the offspring of coils and condensers. With no fence between, they, too, run around the house, mix it up, quarrel and squabble. Howls and squeals result.



So, to keep each "family" or field of individual coils and condensers separated, metal fences are erected (copper fences for the coils) and the individual parts of the Bandbox are shielded as only found in the highest priced sets.

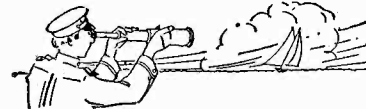

For fans who love to go cruising for faint, far-away signals the "Acuminators" intensify weak signals like powerful lens revealing distant scenes.

The "Bandbox" employs completely balanced or neutralized radio frequency stages, instead of the common form of lossy method of preventing oscillation. In presenting this important feature Crosley is exclusive in the field of moderate price radio.



Volume for dancing be cut from room filling volume to a whisper.

Each "Bandbox" is fitted with a brown cable containing colored rubber covered leads for power and other connections.

The frosted brown crystalline finish harmonizes with the finest furniture and matches the frames of Musicones and the casing of the power unit. The bronze escutcheon creates an artistic control panel.

Withal, in the beautiful appearance and modest size of the "Bandbox" is the utmost in adaptability to requirements of interior arrangement or decoration. The outside case is easily and quickly removed for installation in console cabinets.

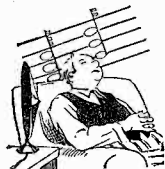

Soft and low thru volume control

AC AND BATTERY OPERATION

The "Bandbox" is built both for battery and AC operation. The new R.C.A.—AC tubes make the operation of the set directly from house current both practical and efficient.

In the AC set the radio stages and the first audio stage use the new R.C.A.—AC—UX-226 tubes. Filaments in these tubes are heated with raw AC current at proper voltage.

Write Dept. 19 for Descriptive Literature.

CROSLLEY RADIO

Crosley Radio is licensed only for Radio Amateur, Experimental and Broadcast Reception.

Five UX201A and one UX171 power output R.C.A. Radiotrons recommended and supplied at standard prices with each Crosley Receiver. Prices slightly higher west of Rocky Mountains.

THE CROSLLEY RADIO CORPORATION

Cincinnati, Ohio



Powel Crosley, Jr., Pres.



A Master Station Selector, with illuminated dial for shadowy corners, enables tuning for ordinary reception with a single tuning knob.

The UY-227, with indirectly heated emitter, is used with the detector. Power tube UX-171 at 180 volts plate.



There is no AC hum. The new R.C.A. Radiotrons do the work.

The power supply convertor is a marvel of radio engineering ingenuity. Half the size of an ordinary "A" storage battery, it supplies A, B and C current direct from lamp socket to tubes.

Price of Power Convertor \$60.

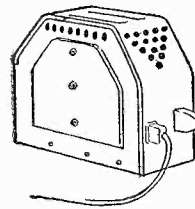

Models for 25 and 60 cycles. Snap switch shuts down set and power convertor completely.

Acme ANTENNA

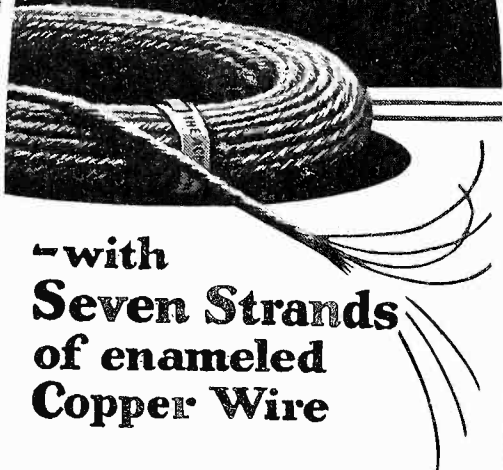

**-with
Seven Strands
of enameled
Copper Wire**

Best outdoor antenna you can buy. Seven strands of enameled copper wire. Presents maximum surface for reception, resists corrosion; this greatly improves the signal. Outside diameters equal to sizes 14 and 16. (We also offer solid and stranded bare, and stranded tinned antenna.)

Loop Antenna Wire

Sixty strands of No. 38 bare copper wire for flexibility, 5 strands of No. 36 phosphor bronze to prevent stretching. Green or brown silk covering; best loop wire possible to make.

Battery Cable

A rayon-covered cable of 5, 6, 7, 8 or 9 vari-colored Flexible Celatsite wires for connecting batteries or eliminator to set. Plainly tabbed; easy to connect. Gives set an orderly appearance.



Acme Celatsite Wire

Tinned copper bus bar hook-up wire with non-inflammable Celatsite insulation, in 9 beautiful colors. Strips easily, solders readily, won't crack at bends. Sizes 14, 16, 18, 19; 30 inch lengths.



Flexible Celatsite for sub-panel wiring

A cable of fine, tinned copper wires with non-inflammable Celatsite insulation. Ideal for sub-panel or point-to-point wiring. Strips easily, solders readily. Nine beautiful colors; sold only in 25 ft. coils, in cartons colored to match contents.

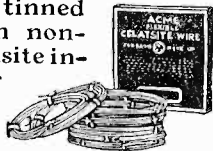

Spaghetti Tubing

Oil, moisture, acid proof; highly dielectric — used by leading engineers. Nine colors, for wire sizes 12 to 18; 30 inch lengths. (We also make tinned bus bar, round and square, in 2 and 2½ ft. lengths.)

Send for folder
THE ACME WIRE CO., Dept. R
New Haven, Conn.

ACME WIRE
MAKES BETTER RADIO

SHORT WAVES IN THE NAVY

(Continued from page 8)

tions with European stations. The amateurs were at first restricted to one-way communication because European countries prohibited transmitting stations not operated by their respective Governments and certain commercial companies. These restrictions have been somewhat modified until now there is active traffic between amateurs over almost the entire world.

In 1922-1923 the Bureau of Engineering, Navy Department, became interested in short wave communication and began experiments along that line. The Naval Research Laboratory soon developed experimental apparatus and commenced operations with amateurs in all parts of the country. These amateurs have already been given credit for the valuable assistance rendered in carrying out the experiments with the Navy.

Experiments by the Naval Research Laboratory at Bellevue, D. C., were augmented by radio personnel on our Naval vessels. The zeal to improve radio communication was admirably shown in the purchase by personal funds of parts for the construction of short wave apparatus. In order to assist forces afloat and to obtain further information concerning the usefulness of short wave operation between Naval vessels, the Bureau of Engineering supplied certain vessels with material which was utilized for the construction of transmitters and receivers by ships' forces. This material, purchased during the War, consisted of tube transmitters and receivers designed for operation on what are now broadcast wavelengths.

Ships' forces made modifications for operation on short wavelengths and after receipt of this material it was not long before the Bureau received reports of increased ranges over the ships' standard installations. These "home-made" sets afforded much aid in moving traffic and in the design of later transmitters. They also demonstrated the economy in operation over the standard installations.

There are disadvantages in short wave communication. For instance, it has developed that a station may be heard at great distances while at the same time this station will not be heard at intermediate points. The signals appear to jump or skip the intervening distance and the term "skip distance effect" has been applied to this phenomenon. This skip distance will vary during the day and with the seasons of the year.

The skipping of signals has been associated with a blanket of ionized atmosphere which surrounds the earth, termed the Kennelly-Heaviside layer from the scientists who conducted investigations therewith. The height of this layer varies from, say a hundred

miles to several hundred miles. Signals received from a radio station apparently do not follow the curvature of the earth but travel in space until reflected from the blanket somewhat as light is reflected from a mirror. According to present day theory the short waves are refracted but the mirror analogy is presented as an aid in explanation. The higher the blanket the greater the distance the signal will be heard on the earth's surface. The Kennelly-Heaviside layer lowers during daylight and summer months. Therefore, the signals from a station being heard distinctly during darkness may diminish as morning dawns, until they entirely fade out.

It has been discovered that when a signal of a certain wavelength fades out, a signal of another wavelength will come through clearly, although of like power output and from the same station. This deficiency has been overcome in the design of transmitters by doubling or tripling the emitted frequency (shorter wavelengths) so that the frequency best suited to existing conditions can be used. It is now believed that the wave from a short wave transmitter makes an angle with the Kennelly-Heaviside layer dependent upon the frequency or wave length. It appears that as the wavelength is decreased the distance of transmission will increase and likewise the skip distance. In other words, the short wavelengths strike the Heaviside layer at a greater angle, thus effecting a greater spanning of the earth's surface.

From an economic standpoint of radio communication, the advantage is greatly in favor of the short wave transmitter. There is no comparison with transmitters which a few years ago were thought to be the last word in development. Take for instance the 500 k. w. arc transmitter at Annapolis with its elaborate antenna system. The antenna system required for a 500 watt short wave transmitter is comparatively simple, usually a single wire approximately 75 feet in length. The power required to operate these transmitters is likewise far from comparison. As for transmission ranges the short wave transmitter under favorable circumstances far outdistances the more powerful transmitter. However, where reliable daylight communication is concerned the power of the short wave transmitter would have to be increased to perhaps fifteen or twenty kilowatts to equal the performance of the 500 kilowatt arc transmitter. Many other such disproportions could be mentioned, such as maintenance costs, operation, etc.

Some may ask, "Why not abandon the costly high power transmitters?" This from a military standpoint is not necessary or required for the present and it will probably be a long time before short wave transmitters fully sup-

plant the more cumbersome and costly arc transmitters.

Although still considered in the experimental stage short wave transmission is used extensively by the military arms of the Government. The Navy department is now in closer contact with the fleet and outlying naval stations. The U. S. S. Memphis, operating in European waters and equipped with a transmitter designed by the Bureau of Engineering, maintains daily schedules with the Navy department with practically entire success. Vessels operating at other distant points effect enormous savings in cable tolls by being able to communicate direct with Washington. The U. S. S. Denver, during the first month of operation of her short wave transmitter while with the Tacna Arica Mission, saved an amount in cable tolls in excess of the cost of the transmitter.

It will thus be seen that the crowding out of the amateurs from the broadcast band was a happy circumstance for all concerned regardless of the shortcomings of short wave transmission.

The Camfield Equaltune condenser is a tuning unit designed so that it can be assembled in from one to five gangs, and is available in capacities from .00025 to .0005 mfd. A particularly rigid method of supporting the movable plates is employed, and the capacity variation is such that a combination of straight line frequency and wavelength is obtained, so as to simplify the tuning over the broadcast band. It is well adapted for use in a single control receiver with drum dial. It is sturdily built and has low electrical losses.

CALLS HEARD

(Continued from page 34)

By 9BQE, F. LaHak, 2515 S. Harrison Street, Ft. Wayne, Ind.

Australia: 2be, 2bg, 2bv, 2gw, (2ij), (2ms), 2rc, 2rt, (2ss), 2sh, 2tm, 2uk, (2yi), 2yt, 3ae, 3bc, 3bl, 3bt, 3dc, (3es), 3hr, (3jk), 3lc, 3lg, 3ls, (3wm), 2xo, (4bd), 4bq, 4mo, 5bg, 5bw, (5dx), 5lf, (5rm), 5wh, 7cs, 7cw, (7cw), 7hl. New Zealand: (1af), (1an), 1fq, 2ae, 2bg, 2br, 2ga, (2gc), 2me, 2of, 2xa, 3ac, 3as, (3cc), 3ux, 4aa, 4ac, 4ae, 4ak, (4am), 4az. Argentine: sa-fc6. Brazil: (sb-1ib), sb-1ak, sb-1ar, sb-1au, sb-1ca, sb-2ma. Chile: sc-2ah, (sc-2ar), sc-2as, sc-2bl. Uruguay: su-1qo, su-2ak. Venezuela: ayre. Nicaragua: (m3y). Hawaii: 6hdl, (6xy). Mexico: 1k, (1n), 1j, 5c, xcf. Jamaica: (2pz). Costa Rica: (cto). France: 8fr, 8jf, 8ix, 8tis, (8yor). Italy: idol, aul, if. England: 5xy. Belgium: 4rs, 4ww. Germany, 4dba. Portugal: lae. Tibet: zx2, fo-a3b, aye, dsz, ug, nidk, (drz), (kdgl), (ved), unknown, pse, qsl, hgz, ffjp, 25ar, s5c, aaje, ardi, arcx, kle, nem, nvd.

By 6AGR, Angus H. McCallum, 1507 14th Street, San Pedro, Calif.

1air, 1caa, 1saw, 1cos, 1fq, 1zn, 2aes, 2aqu, 2awq, 2awr, 2aua, 2axe, 2czr, 2ea, 2xt, 2xaf, 2xai, 2xc, 3ac, 3wx, 4du, 4eg, 4ll, 4ok, 4sp, 5ahp, 5aff, 5avb, 5bh, 5hg, 5hq, 5iu, 5pr, 5rg, 5tt, 7abh, 7ach, 7adg, 7am, 7acp, 7ajn, 7ajl, 7buy, 7gf, 7gn, 7nv, 7nc, 7rg, 7ur, 7uj, 7xx, 8amh, 8avb, 8bgo, 8evs, 8cnt, 8cqu, 8dcm, 8jf, 8li, 9aek, 9aex, 9ahj, 9aon, 9auu, 9arn, 9aaq, 9bng, 9bbh, 9bn, 9bng, 9bgg, 9bht, 9cnt, 9cnd, 9cdw, 9cmv, 9dha, 9dul, 9dr, 9drv, 9dvy, 9dyu, 9eas, 9eev, 9ff, 9ju, 9ro, 9sa, 9to, 9uu, 9wz, nc3cs, nc5ac, nc5au, nc5bg, nc5co, nc5nf, nc5lf, oh6acq, oh6ch, oh6exy, oh6cdv, oa2lf, oa2rc, oa4cu, oa5hg, oa5lf, oa6oa, oa7hl, oxles, ozlan, oz2ae, oz2ar, oz4aa, op3ac, ajlsk, jkzb, ffjp, sc2ag, sc2as, sc2bl.

AMERTRAN AMERTRAN AMERTRAN

Two New AMERTRAN Power Transformers for Use With New Tubes!

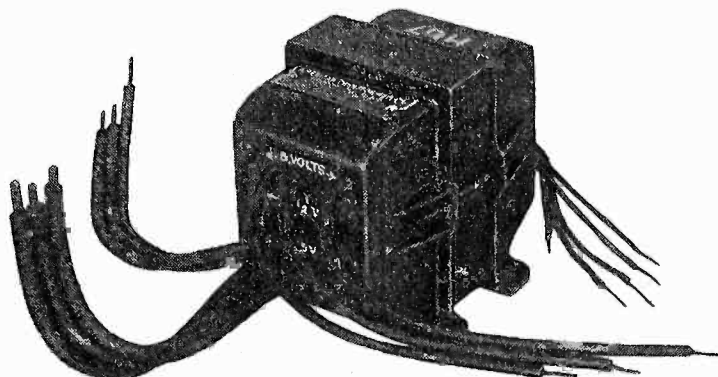

AmerTran Filament Heating Transformer

Type H-67, \$12.00 each

This transformer is intended for use with the new RCA UX-226 raw AC amplifier tubes and the new UY-227 detector tube. It also has a third filament winding capable of handling two UX-171 tubes. In connection with the new AC tubes, the type H-67 becomes the power source for the filament and is therefore a real "A" battery eliminator.

If you have a good plate supply system and a set with the new AC tubes and one or two UX-171 power tubes in the last stage, the H-67 AmerTran is ideal, transforming the 50 or 60 cycle, 110 volt AC house light current down to the lower voltages for the correct operation of the new tubes.

AmerTran Power Transformer

Type PF-281

This unit is designed for use with the new UX-281 rectifying tube; which can be operated at 550 volts plate up to a maximum of 750 volts plate and deliver 110 milliamperes DC as a half wave rectifier. A 750 volt plate winding with a tap for 550 volts enables the transformer to be used either with a UX-281 or 216-B rectifying tube, where the output plate voltage is not required to be in excess of 450 volts.

In addition to the plate and filament windings for the rectifier and power tubes, the type PF-281 has filament heating windings (similar to the H-67) for the new AC tubes, and thereby incorporates in a single transformer unit the means for converting AC house current into filament and plate current, and grid bias potential. When used with our type 709 and 854 Amer Chokes in the filter circuit it is possible to construct a radio receiver which can be operated entirely from the house lighting circuit without an "A" eliminator, trickle charger or batteries.

Like all AmerTran power devices this transformer has been generously designed to operate at a very low core density reducing the hum from stray fields to a minimum. Utmost efficiency has been sought regardless of cost.

Write for further information, including booklet "Improving the Audio Amplifier."

AMERICAN TRANSFORMER COMPANY

178 EMMET STREET, NEWARK, N. J.

"TRANSFORMER BUILDERS FOR OVER 26 YEARS"

AMERTRAN AMERTRAN AMERTRAN

Tell them that you saw it in RADIO

Aero Coils

Recommended Again

for use in the
SHORT WAVE CONVERTER

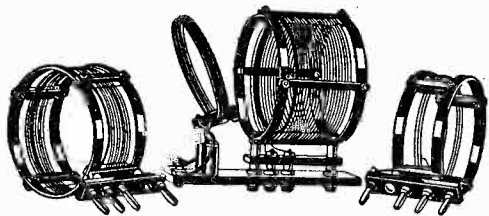

Low Wave Tuner Kit
Price \$12.50

In his article printed in "RADIO" for May, Mr. Perry Graffam describes the construction of an unusually efficient short wave converter. Of course he specifies AERO Low Wave Tuner Kit as the inductances to use in this converter. This kit is completely interchangeable and has a gapless range of 15 to 130 meters. Kit includes 3 coils and base mounting. Range can be reduced to 13 meters by use of AERO Coil INT. O (Price \$4.00) or increased to cover broadcast band by use of AERO Coil INT. 4 (Price \$4.00) and INT. 5, described below.

Aero Interchangeable Coil No. 5

Normal range 235 to 550 meters. Range can be increased to 725 meters by use of .0001 Sangamo fixed condenser across rotor and stator of .00014 variable condenser. This gives coverage of Airplane to Airplane, Land to Airplane, and Ship to Shore (Great Lakes and Atlantic and Pacific Oceans) bands. Price of INT. 5, \$4.00.

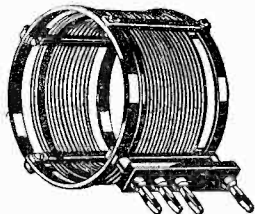

You can get these AERO coils from your nearest dealer. If he should be out of stock, order direct from the factory.

AERO PRODUCTS, Inc.

Dept. 103, 1772 Wilson Avenue, Chicago, Ill.

Pacific Coast Representative
HENGER - SELTZER CO.
Los Angeles and San Francisco

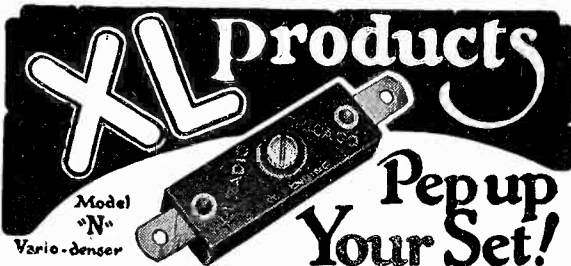

Model "N"
Vario-Denser

VARIO DENSER

Tune quickly—adjust accurately—eliminate distracting noises—get correct tube oscillation—with X-L VARIO DENISERS in your circuit. Designers of all latest and best circuits specify and endorse them.

MODEL "N"—Slight turn obtains correct tube oscillation on all tuned radio frequency circuits. Neutrodyne, Roberts two tube, Browning-Drake, McMurdo Silver's Knockout, etc. Capacity range 1.8 to 20 micro-microfarads.
Price \$1.00

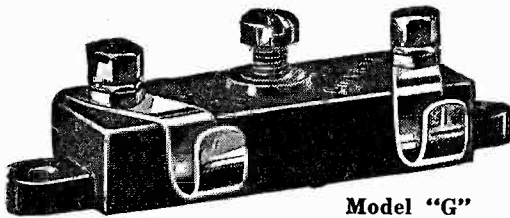

Model "G"

MODEL "G"—With grid clips obtains the proper grid capacity on Cockaday circuits, filter and intermediate frequency tuning in heterodyne and positive grid bias in all sets.

Capacity range:

Model G-1 .00002 to .0001 M. F. D.
Model G-5 .0001 to .0005 M. F. D.
Model G-10 .0003 to .001 M. F. D.

Price \$1.50

X-L PUSH POST—Push it down with your thumb. Insert wire, remove pressure and wire is firmly held. Vibrations will not loosen. Releases instantly.

Price 15c

X-L PUSH POST PANEL—Permanently marked in white on black insulating panel. In box including soldering lugs, raising bushings and screws for mounting, etc.

Price \$1.50



X-L Push Post

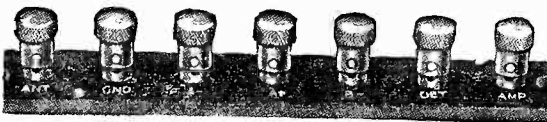

X-L Push Post Panel

Built the new LOFTIN-WHITE constant coupled radio frequency circuit. FREE wiring diagrams showing use of this and other popular circuits sent on request.

XL Radio Laboratories

2428 Lincoln Ave.

Chicago, Ill.

INFRADYNE MANUAL

SHOWING LAST SEASON'S MODEL, & HOW TO TEST IT. "RADIO" SAN FRANCISCO

25c

FILTER CONDENSERS

Manufactured by Dubilier Condenser & Radio Corp.

1 3/4 mfd. 1000 volts rated D.C. Working Voltage. Extra Special at \$1.35 each

7 mfd. 600 volts rated D.C. Working Voltage. Extra Special at \$3.50 each



Manufactured by Stromberg-Carlson Tel. & Mfg. Co.

3 1/2 mfd. 600 volts rated D.C. Working Voltage. Extra Special \$1.75 each

All of these High Quality Filter Condensers are brand new, and guaranteed as rated. They are excellent for use in your Eliminator, Transmitter, or Experimental Work.

AMERICAN SALES CO.

21 Warren Street, New York City

1928 INFRADYNE

(Continued from page 14)

tube at the far right-hand end of the base and nearest to the Infradyne Amplifier should light. The pilot light over the left-hand dial should also light. Now turn the switch to the "DISTANCE" position. Adjust the panel rheostat so that the voltmeter registers three volts. All tubes in the set and the pilot lamps above both the right and left-hand dials should light. Momentarily remove each of the CX 299's in turn and watch the voltmeter. If the tube removed was lighted the voltmeter should register a higher voltage while the tube is out of the socket.

If all the tubes are found to light properly turn the switch off and connect up the B and C batteries using the color scheme given above. Connect the blue battery cable wire to the 22 1/2 volt B battery terminal, the brown battery cable wire to the 67 1/2 volt B battery terminal, the slate wire to the 90 volt B battery terminal and the yellow wire to either the 135 or 180 volt B battery terminal. If a CX 112 tube is used in the second audio stage a plate voltage not higher than 135 should be used; if a CX 371 tube is used a plate voltage of either 135 or 180 can be employed. The C battery voltage used will depend upon the type of second audio tube and upon the plate voltage employed. Connect up the antenna and ground and plug a pair of phones into the jack on the control panel.

Turn the switch to the "LOCAL" position. Set the inner part of the antenna compensator control knob at 3. Adjust the outer part of the antenna compensator control knob so that the moving coil in the compensator makes an angle of about 45 degrees with the stationary coil. The left-hand tuning dial should read zero with the plates of the condenser in the radio frequency amplifier wide open or, in other words when the capacity of this condenser is a minimum. Turn the "VOLUME" control about four-fifths of the way on. Now rotate the left-hand dial slowly, beginning at zero, until a station operating on a wavelength in the neighborhood of 200 meters is picked up.

The balancing condenser which is connected across the antenna section of the gang condenser in the radio frequency amplifier must next be adjusted in conjunction with the antenna compensator. The antenna section of the gang condenser is that at the rear or, in this case, left-hand end. The balancing condenser which is to be adjusted is located at the end of the gang condenser farthest from the dial shaft; it is mounted, together with two other balancing condensers, on a bakelite sheet supported below the plates on the die-cast aluminum condenser frame.

This balancing condenser is controlled by a screw; the farther down the screw is turned the greater will be the balancing condenser capacity and the farther out the screw is turned the less will be the balancing condenser capacity. A special wooden wedge is furnished with the radio frequency amplifier for use in adjusting the balancing condenser. The antenna section balancing condenser has been adjusted for average conditions before leaving the factory and will need to be changed only slightly. Try varying the capacity of the antenna section balancing condenser by small amounts, rotating the left-hand tuning dial back and forth past the station setting after each adjustment. The balancing condenser should be set at the position for which tuning is sharpest and volume is greatest. When the balancing condenser has been correctly adjusted the approach to the point of maximum volume for the station used for test will be uniform on either side of the dial setting and there will be but one peak on the dial for the station.

When the balancing condenser has been adjusted, rotate the left hand tuning dial until a long-wave station is picked up, one operating on a wavelength of about 500 meters. Now adjust the antenna compensator, which is operated by the outer part of the antenna compensator control knob, until tuning is sharpest and volume is a maximum. During adjustment of the compensator for the long-wave station leave the balancing condenser setting unchanged.

Again tune in the short-wave station for which the balancing condenser was adjusted and, without changing the antenna compensator setting, readjust the balancing condenser in the manner above described. Now tune in stations over the entire scale and note volume and sharpness of tuning. If the balancing condenser and antenna compensator have been correctly adjusted it should be unnecessary to vary the setting of the antenna compensator to obtain maximum sharpness at different wavelengths. If it is necessary to vary the antenna compensator setting a different combination of compensator setting and balancing condenser capacity should be found which will produce the desired results. Final adjustment of the balancing condenser and compensator should be made on stations four or five hundred miles distant.

The three settings of the lower part of the antenna compensator control knob represent three values of antenna coupling; when the control knob is set at three the coupling is a maximum and when it is set at one the coupling is a minimum. The correct setting to use will depend on the length of the antenna and conditions, as regards broadcast congestion, under which the set is to be

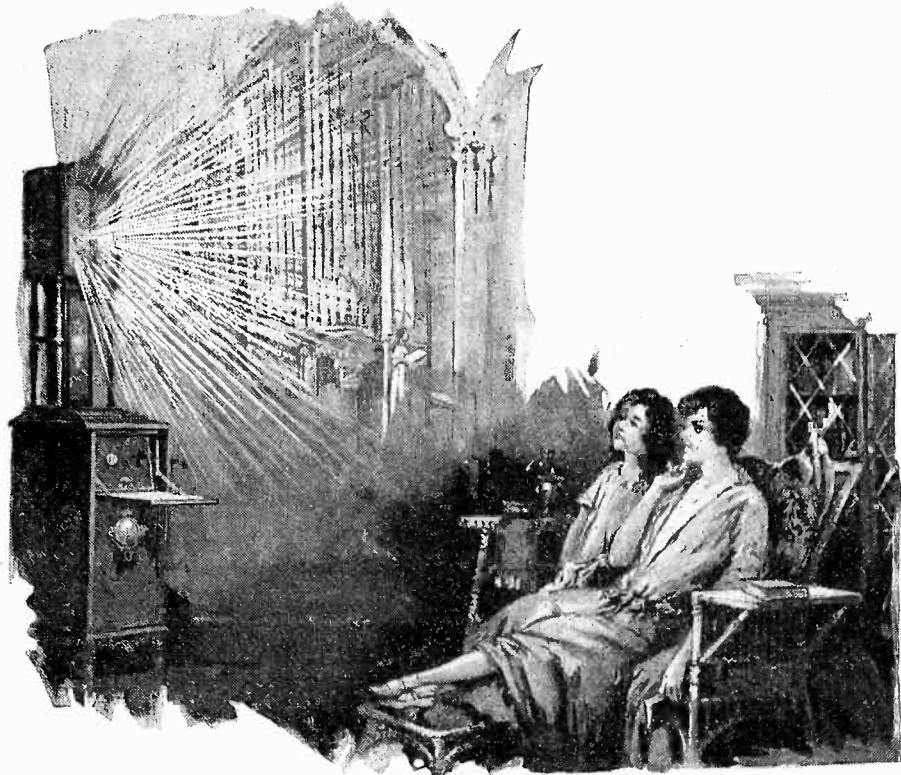

TO POSSESS a radio set equipped with Thordarson Amplification not only indicates taste and discrimination, but points to the owner's appreciation of the intangible beauties of perfect reproduction of fine music.

More and more, leading receiver manufacturers have been brought to the realization of the musical supremacy of Thordarson Amplification until Thordarson Transformers now are found in the majority of quality radio sets.

Whether buying or building your receiver — if you enjoy good music — insist on Thordarson Amplification.

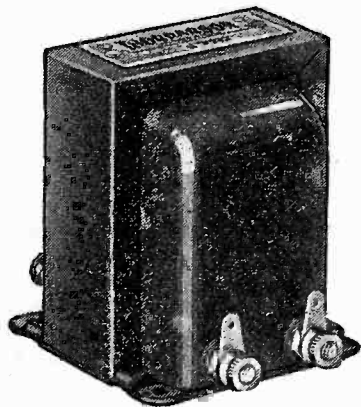

THORDARSON
AUDIO
AMPLIFICATION

Supreme in
MUSICAL PERFORMANCE!

THORDARSON ELECTRIC MANUFACTURING CO.
Transformer Specialists Since 1895
WORLD'S OLDEST AND LARGEST EXCLUSIVE TRANSFORMER MAKERS
Huron and Kingsbury Streets — Chicago, Ill. U.S.A.

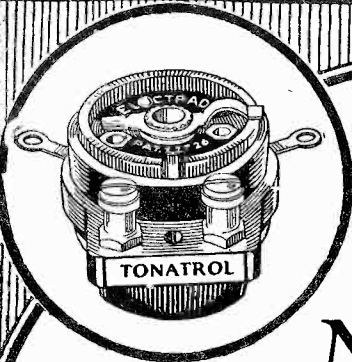

Licensed by
Technidyne
Corporation
under U. S.
Patent No.
1593658,
July 27, 1926

New!

"TONATROL"

A True Tone and Volume Control

Now you can regulate volume smoothly and evenly—from a whisper to full power with this startling new Electrad device!

"Tonatrol" is a smart addition to any receiver. Very neat in appearance and constructed of genuine Bakelite. Quickly and easily installed.

"Tonatrol" Standard
Type\$1.50
"Tonatrol" Type W. S.
(with filament switch
attached) 2.50

At your dealer's

Write for free installation
booklet explaining the cor-
rect way to control volume

Dept. 54, 175 Varick St., New York, N.Y.

ELECTRAD

In His New

Impedance Equalized Receiver

MR. FRANK JONES

The Designer, Specifies

HAMMARLUND Condensers and Coils

IT PAYS
TO USE
THE BEST

Twenty-nine leading radio designers
officially specify Hammarlund Prod-
ucts for their newest circuits. If your
dealer cannot supply you, write to us.

HAMMARLUND MFG. CO.
424-438 W. 33rd Street, New York City

For Better Radio
Hammarlund
PRECISION
PRODUCTS

SANGAMO

MICA CONDENSERS

UNAFFECTED

by

MOISTURE

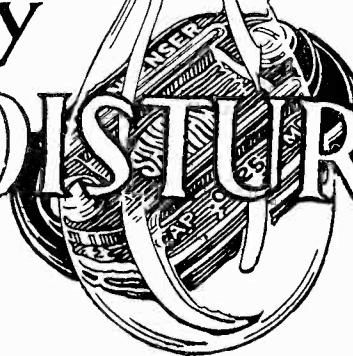

When the humidity hovers around 100, the components of your radio receiver are subjected to the equivalent of a water bath!

You can make certain, at least, that the fixed condensers in the circuit will not alter in capacity or efficiency under these conditions.

Use Sangamo Mica Condensers — they are permanently protected from all atmospheric action by a solid sheathing of pure bakelite!

Sangamo Electric Company
Springfield, Illinois

6336-8

operated. The smaller the amount of coupling used, the greater will be the selectivity. For a very long antenna minimum coupling should be used and for a short antenna maximum coupling should be employed. When the degree of antenna coupling is varied adjustment of the outer part of the compensator control knob will be necessary; the balancing condenser setting will not have to be changed.

The radio frequency part of the set is now ready for operation. Put the cover on the radio frequency amplifier and fasten it in place. Tune in stations over the entire wavelength range and either log the dial settings or write in the wavelengths or frequencies on the dial. When familiarity with the operation of the set with the switch turned to "LOCAL" has been gained, adjustment of the Infradyne can be undertaken.

See that the right-hand dial reads 200 when the plates of the Type 659 Remler Condenser are wide open, that is, when the capacity of this condenser is a minimum. Using the wooden wedge furnished with the Infradyne Amplifier turn the four Infradyne Amplifier tuning controls to zero. Turn the Infradyne Amplifier "Increase" screw about two-thirds of the way down. Use the fingers in adjusting the "Increase" screw—do not use pliers or great pressure as damage to the Amplifier will result. Turn the switch to the "DISTANCE" position and set the panel rheostat so that the voltmeter indicates three volts. Set the left-hand dial for a station preferably a moderate distance away. Set the "Sensitivity" control to the point just beyond which a series of whistles is heard as the right-hand tuning dial is rotated. If these whistles do not disappear when the "Sensitivity" control is turned all the way back, turn the Infradyne Amplifier "Increase" screw outward. The "Increase" screw should be adjusted so that the whistles appear when the "Sensitivity" control has been advanced about 1-3 of its range. Now rotate the right-hand dial until the station for which the left-hand dial is adjusted is brought in.

Consider the Infradyne Amplifier tuning controls, reading from left to right, as numbers one, two, three, and four. Leaving knob number two set at zero, adjust knob number three for maximum signal strength while rotating the right-hand tuning dial slowly back and forth past the station setting. Next set knob number one for maximum signal strength, rotating the right-hand dial during adjustment as before. Knobs numbers one, two and three having been adjusted, it remains only to adjust knob number four. Rotate the right-hand dial during adjustment as before. Knob number four will be found to tune more broadly than knobs one, two or three. As the various Infradyne Amplifier tun-

New KITS

Write for prices on
the newest of 1928
Radio Kits

"Laboratory Tested"

Laboratory of "RADIO"
435 Pacific Bldg.
San Francisco - California

Tell them that you saw it in RADIO

"NO OSKILLATE"



"NO WORKEE — NO OSKILLATE — NO GOOD" — exclaimed the two Oriental radio fans as they made a difficult attempt to tell us that their intermediate transformers were not delivering the goods. They knew of the services rendered by the laboratory of "RADIO"—and they brought their troubles to us. Best and McGown quickly checked the intermediates—found them to be badly in need of matching—made the necessary changes and returned the transformers to our Chinese friends. Now their set works fine. They can't understand English—but they *do* know good music when they hear it. Matching intermediate transformers is a specialty with us. If you want to get the most out of your set — for two dollars and fifty cents — send us your intermediates for matching.

Rates —

SETS CHECKED: Complete laboratory test and check of all parts, including any type or make of set.....	\$5.00
<small>This includes a complete check-up of all parts, matching of radio frequency coils, elimination of "bugs," etc. Sets must be shipped complete with tubes and circuit diagram, unless of standard type or make, when diagrams may be omitted. (Extra charge if diagram is not supplied.)</small>	
Intermediate Frequency Transformers. Transformers matched, to optimum frequency and filter tuned to resonance.....	2.50
<small>Condenser to tune filter extra. Transformers rewound and calibrated to a specified frequency for \$2.00 per transformer. STATE TYPE TUBE TO BE USED.</small>	
Radio Frequency Coils. Matched to resonance with a gang or bank condenser, per set of 3 coils.....	2.50
<small>(Coils and condensers both must be submitted.)</small>	
WAVEMETERS and Oscillators. Covering all wavelength (frequency) bands from 10 meters up, with 1 coil only. At least 5 points furnished	2.50
Additional coils, per coil.....	1.00
Curves drawn, per curve.....	1.00

WRITE FOR QUOTATIONS ON SPECIAL TESTING AND ENGINEERING SERVICE

PARTS

Any part made by any radio factory can be supplied by us. Before parts are shipped to our customers we make a careful inspection. When you buy parts from the laboratory of "RADIO" you know in advance that you can't go wrong.

HOW TO ORDER

When ordering parts from the laboratory be sure to specify Manufacturer's name, type number and style. C.O.D. orders accepted if half cash accompanies order. Prompt deliveries assured.

Testing and Calibration Laboratory

Pacific Radio Publishing Company

Established 1917



PACIFIC BUILDING

SAN FRANCISCO-CAL.

KITS

The many new kits of the season can be supplied by the laboratory of "RADIO." Let us send you a real matched and tested kit for any circuit. The usual retail prices prevail. No extra charge for matching.

Tell them that you saw it in RADIO



— And now the Fada "Special"

— Harmonated Reception at a Popular Price

Without question the simplest, high-powered and low-priced 6-tube shielded set ever presented. Designed by Fada engineers—every part made by Fada workmen according to Fada's rigid standards, in the Fada plant—it excels in all-round performance anything offered at anywhere near its price! Hear it today! You'll be amazed!

F. A. D. ANDREA, New York, San Francisco, Chicago

Fada Cone Speaker

22 inch, free floating cone — permanent Parkerized magnet, Cone of Grecian design. Antique bronze finished trifoof.
Pacific Coast Price \$37.00

The Fada Special

6 tube—3 radio frequency stages detector — 2 audio amplification stages. Individual stage shielding. Equalized amplification.
Pacific Coast Price \$99.00

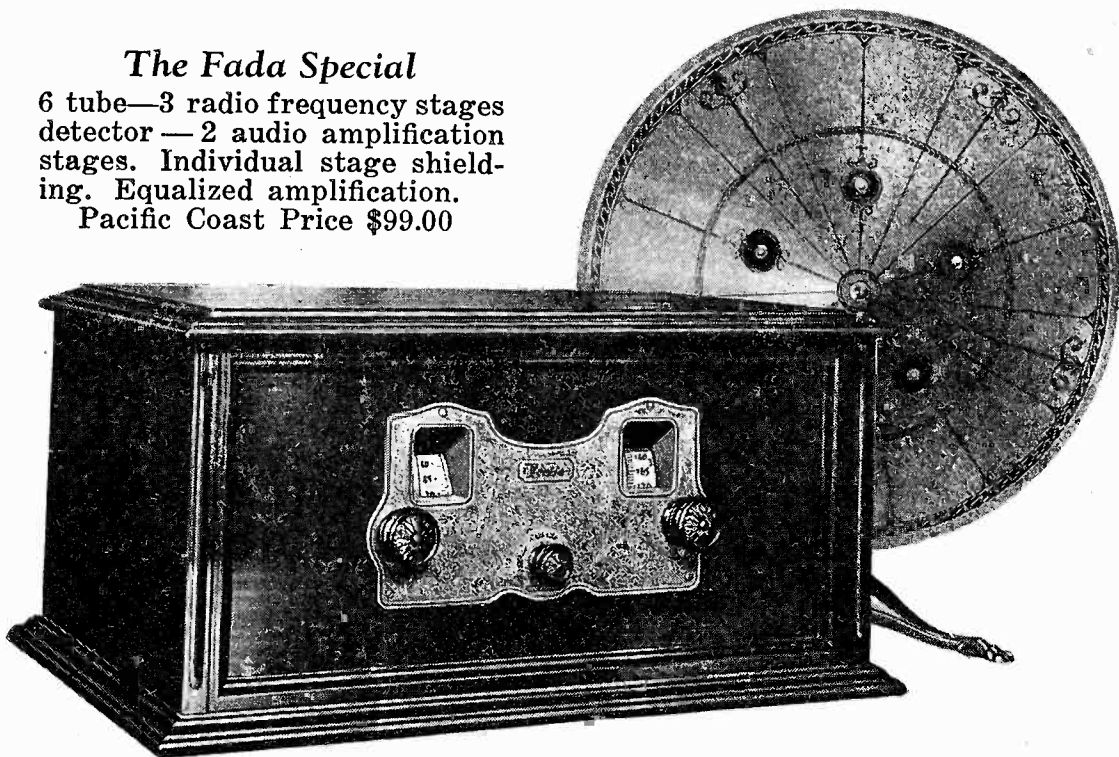

Licensed under Hazeltine Corporation Patents, Latour Corporation Patents, Radio Corporation of America Patents. Licensed only for Radio Amateur, Experimental and Broadcast Reception.

ing controls approach the correct settings the Amplifier will probably go into oscillation, that is, a whistle will be heard as the station setting is passed. If this should happen turn the "Sensitivity" control back or turn the Infradyne Amplifier "Increase" screw out. Tuning of the right-hand dial as well as tuning of the Infradyne Amplifier controls will be sharpest when the "Sensitivity" control has been adjusted to the critical point above mentioned, that is, the point just beyond which a series of whistles is heard as the right-hand dial is rotated. Final adjustment of the Infradyne Amplifier tuning controls should be made on a station at least four or five hundred miles distant.

In operating the Infradyne several things should be kept in mind. When the switch is in the "LOCAL" position only the left-hand tuning dial and the "VOLUME" control will be used. As a final adjustment on very weak signals a slight change in the setting of the outer antenna compensator control knob might be desirable; it should not be necessary to use the antenna compensator for ordinary reception once it has been correctly adjusted. When the switch is in the "LOCAL" position the "Sensitivity" control and the right-hand tuning dial will have no effect and should be left alone. When only five tubes are being used the voltmeter will also fail to register. Greater volume will be obtained with the antenna compensator switch set at 3 than will be obtained with it set at 1 or 2 but in locations where there are many broadcasting stations one of the latter two points should be used. A change in the setting of the antenna compensator switch will necessitate adjustment of the outer part of the antenna compensator control knob.

With the switch in the "DISTANCE" position, the "Sensitivity" control and both tuning dials will be used in addition to the "Volume" control. The voltmeter should always indicate 3 volts. For reception of distant stations or for maximum selectivity the "Sensitivity" control should be set at the critical point above discussed. For reception of nearby stations the "Sensitivity" control can be used in conjunction with the "Volume" control to control volume and quality of reproduction.

The two tuning dials should read nearly alike over the entire scale. The setting of the right-hand tuning dial for a given wavelength can be varied by adjusting the special semi-fixed condenser shunted across the Remler Type 659 Condenser. Adjustment of this special condenser should be left until the operator is fairly familiar with the receiver. At such time the change can be made so that the dials will agree at any desired wavelength.

Intermediate Transformers MATCHED

Let Gerald Best and D. B. McGown match and "peak" the intermediate transformers for your super. Proper fixed condensers will be attached. This entire service for \$2.50. Condensers extra.
Laboratory of "RADIO," San Francisco

HEAR the wonderful
New Acme Speaker at
your dealer's

ACME
for amplification



TOBE

B
Blocks

Tiny
Tobes

CONDENSORS — RESISTORS
Specified — Used — Universally
Tobe Deutschmann Co., Cambridge, Mass.

Intermediate Transformers MATCHED

Let Gerald Best and D. B. McGown match and "peak" the intermediate transformers for your super. Proper fixed condensers will be attached. This entire service for \$2.50. Condensers extra.
Laboratory of "RADIO," San Francisco

When all adjustments have been made we will be ready to procure the crystalline enameled copper cabinet and the decorative wooden base. The pressed steel base will be set into the wooden base and the copper cabinet, which fits into the wooden base and closely around the steel base, can be placed in position.

We now have a receiver which is amply selective to cope with modern broadcasting conditions and which offers quality of reproduction equal to that obtainable anywhere. By turning the switch to "LOCAL" economy of operation is increased and the greatest possible simplicity in tuning is obtained—equal success awaits any member of a family who wishes to partake of the pleasures which radio brings. For the man who wants "DX" and extreme selectivity the complete Infradyne is immediately available.

At KFZH, Detroit News Wilkins Expedition, Station at Mile Eighteen Fairbanks, AAA.

During time of operation February 27-28 and March 25 to June 5th:

Ac8flo, ajlsk, ajlsm, eb, 4rs, efno, 8jf, 8jn, 8ez, 8jj, eg2xy, 5hs, 5xy, 6yq, es2co, na, 7aam, 7aeb, 7aeb, 7dq, 7gz, 7kn, kdfu, kxw, ml4, wux, wwdw, wxp, wxpl, wut; NC cka, 4cl, 4cp, 4dw, 4eh, 4fv, 4pd, 5aj, 5aw, 5ar, 5ao, 5bg, 5fs, 5gt, 5fn, 9bz, NJ2pz, NZ2ga, NULaga, lasu, lbhs, kfzq, Connecticut, lbyv, 1cmx, 1yb, 2abp, 2aby, 2ahm, 2amj, 2anm, 2bdm, 2cev, 2cxl, 2ox, 2uo, 2xai, 4ac, 4ce, 4dd, 4fa, 4fu, 4ll, 4oc, 4ok, 4rp, 4qz, 4si, 4tu, 4uu, 4yn, 5agj, 5ahp, 5aky, 5ao, 5aqf, 5aqs, 5co, 5eb, 5em, 5fs, 5gx, 5ja, 5ql, 5uk, 5zai, 5av, 6aak, 6abg, 6adh, 6adn, 6adp, 6aej, 6ahn, 6ahs, 6ajl, 6akf, 6akp, 6akw, 6alt, 6anc, 6aod, 6apa, 6asq, 6aqx, 6auk, 6awq, 6axv, 6azs, 6bbn, 6bch, 6bgb, 6bgh, 6bhk, 6bjh, 6bjv, 6bjx, 6bks, 6bmo, 6bmw, 6bmy, 6bod, 6bom, 6bpm, 6bsv, 6bv, 6bxd, 6bxl, 6bxn, 6bys, 6byz, 6ccl, 6ccr, 6cdv, 6cfo, 6che, 6chn, 6cil, 6lj, 6cng, 6cke, 6col, 6crl, 6csx, 6cte, 6cua, 6cuu, 6cuw, 6cvc, 6cwk, 6czz, 6czu, 6dau, 6dfe, 6dfw, 6dgy, 6dhe, 6dic, 6co, 6ew, 6fh, 6gd, 6gu, 6hh, 6hm, 6im, 6jd, 6ju, 6kb, 6oe, 6rh, 6rj, 6rr, 6sm, 6tn, 6ve, 6vr, 6aae, 7aat, 6abh, 7abk, 7abm, 7acf, 7acf, 7acx, 7adg, 7ae, 7ay, 7bb, 7bm, 7df, 7ec, 7eh, 7ek, 7fh, 7fs, 7gb, 7gk, 7gj, 7gp, 7iv, 7iz, 7jf, 7jp, 7lr, 7mo, 7nj, 7lz, 7no, 7qb, 7rh, 7rl, 7uc, 7ur, 7wb, 7wc, 7xf, 7xw, 8acu, 8acy, 8alr, 8aly, 8amb, 8aov, 8avs, 8axa, 8abvx, 8azh, 8bwr, 8ccm, 8ccs, 8ced, 8cpl, 8evo, 8dan, 8das, 8deb, 8dcm, 8ded, 8dkt, 8dl, 7doi, 7dok, 8eq, 8ew, 8ik, 8im, 8nt, 8pl, 8qb, 8vx, 8wo, 8xe, 8zg, 9adg, 9ado, 9ahj, 9ajd, 9alm, 9amu, 9aon, 9anz, 9apm, 9arn, 9auu, 9axb, 9bbk, 9bgy, 9bpl, 9bpm, 9bqc, 9buy, 9bvk, 9bwb, 9bwo, 9caj, 9cei, 9cet, 9cia, 9ckf, 9cns, 9cos, 9cpm, 9cpq, 9cvn, 9cya, 9czw, 9dbw, 9deq, 9dfw, 9dge, 9dka, 9dkc, 9dng, 9dpb, 9dwd, 9dws, 9ecz, 9edr, 9eea, 9eev, 9efo, 9ekf, 9ekn, 9emb, 9cn, 9cv, 9dr, 9dz, 9ek, 9es, 9it, 9kd, 9kv, 9sa, 9so, 9sv, 9uz, 9vv, 9wi, 9xi, OA, 1fs, 2ds, 2dy, 2gw, 2hm, 2jp, 2jy, 2mh, 2no, 2ms, 2rb, 2rc, 2rx, 2sh, 2ss, OA2xi, 2yi, 3bq, 3dc, 3ef, 3es, 3gf, 3hl, 3lg, 3my, 3tm, 3rb, 3wm, 3vp, 3zy, 4az, 4bd, 4cg, 4cm, 4go, 4lj, 5bg, 5bw, 5by, 5cm, 5dx, 5hg, 5ja, 5lf, 5lu, 5wh, 5ws, 6sa, 7cw, 7hl, 7om, 7gh, OP1hr, 1au, OZ, 1an, 1fq, 2ac, 2ae, 2as, 2at, 2bx, 2gc, 2gg, 3aj, 3au, 3ar, 4aa, 4ac, 4ae, SA-cb8, sc2bl, arcx, ardi, aa7, nr-CTO, agb, bei, dez, ffp, glq, jkzb, joc, juk, jzb, jyz, kfsx, kif, kda, fr3, Ojk, naa, noh, nba, npl, npm, npn, npo, npu, npa, wct, wvt, wuaa, wvc, vok, prk, vis, perr, nidk.

Q R A's

7PH—Portable 7ABV (ex7HE), Leo Sands, 2119 McDougall Ave., Everett, Wash.

GBM—Post Office Radio Station, Leafield, Oxford, England.

es2CO, es1CO, es2NN—Lieut. E. V. R. Lind, Laka Santahamina, Helsinki, Finland.

2UA, B. D. Jones, formerly 75 St. Nicholas Place, New York City, now 2254 Cedar Ave., Bronx, New York City—75 watts 40 meter.

CN9AJ, British Columbia Amateur Radio Association, 3423 Pender St., East, Vancouver, B. C.

Most satisfying to the musically critical when used in a good circuit.

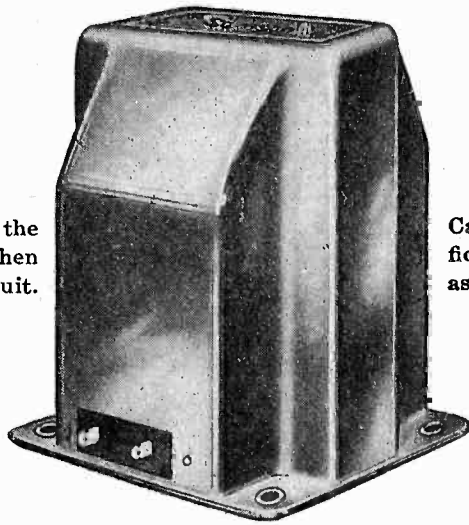

Causes proper amplification of high notes as well as low ones.

Exactly Interprets Broadcast Music

JUST as Wagner revolutionized Grand Opera by making music interpret the action of characters on the stage, Samson has improved radio by making radio music exactly interpret the characters in the broadcasting studio.

So perfect is the naturalness that results from the use of

Samson Symphonic Transformers

which amplify the overtone as well as the fundamental, that any further improvement could not be detected by the human ear.

You can, therefore, now build a set of lasting satisfaction, or hear this wonderful improvement for yourself by asking your dealer to slip a pair of Samson Symphonic Transformers in place of the ones now in your set.

Our book—"Audio Amplification"—accepted as a manual of audio design by many radio engineers—contains much original information of greatest practical value to those interested in bettering the quality of their reproduction. Every radio enthusiast should have a copy.

SAMSON ELECTRIC COMPANY
Manufacturers Since 1882

Sales Offices in
Thirty Leading Cities



Main Offices at
Canton, Mass.
Factories:
Canton and Watertown

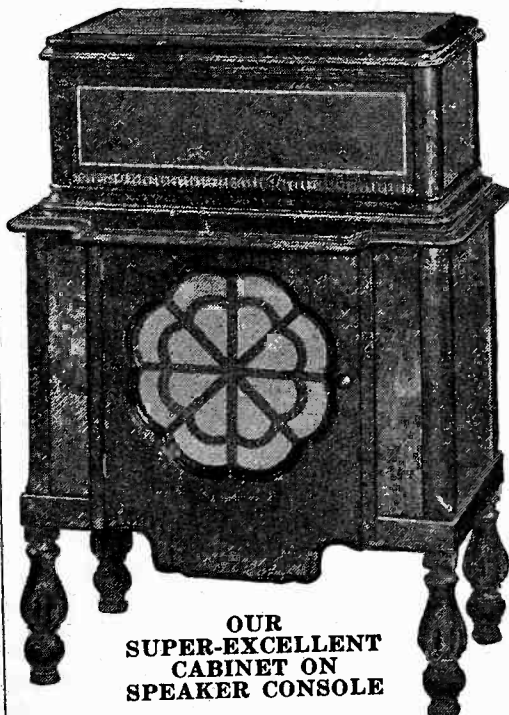

OUR
SUPER-EXCELLENT
CABINET ON
SPEAKER CONSOLE

Radio Cabinets

This cut shows our Super-Excellent Table Cabinet on our Super-Excellent Speaker Console. This is only one of our 10 latest conceptions of Radio Furniture. We have an unusual display of Furniture designed and built exclusively as Radio Furniture.

Send for catalog and descriptions and you will find that we are listing and carrying, ready for immediate shipment a very beautiful line. From all forecasts it is apparent that Radio Furniture will be the dominating factor in radio sales this coming season. Sets in our Cabinets will make sales. Special Cabinets Built to order in quantities.

Ehlert Radio Furniture Company
2468 Lincoln Avenue, Chicago, Ill.

Show Rooms and Large Stock Carried in Chicago.

Manufacturers of: RADIO CABINETS, RADIO DESKS, RADIO CONSOLES, RADIO TABLES.

Tell them that you saw it in RADIO

NATIONAL B-Power Supply

A newly designed B-Eliminator, with special features not hitherto offered to the public, will be announced in the near future. The unit is small, light, simple and easy to set up. The price will be attractive.



The new NATIONAL B-POWER SUPPLY is manufactured under license association with Radio Corporation of America, General Electric Co., Westinghouse Electric and Manufacturing Co., and the American Telephone and Telegraph Co.



BE SURE YOU GET THE GENUINE

NATIONAL RADIO PRODUCTS

NATIONAL · CO · INC · W · A · READY · PRES · MALDEN · MASS ·
Send for Bulletin R-8

SWEETHEART'S LOVE AFFAIR

(Continued from page 20)

things were going a very thin communication could be obtained, enough to tell them that we needed help, but there was no way to get the thousands of important messages out from Yokohama to Tokio and from there to the world, unless the big commercial station whose broken mast I could see from the ship, could be got working.

All the Japanese operators at the station had been killed, and there were no other operators in the city. Several of us ops on the various ships, including the Japanese war ship, could have gotten together and gone ashore, but we had heard the land station was a ruin so we felt sure we couldn't do anything. You can't rebuild a whole station in a day.

I told this to Sweetheart. He hadn't thought about the necessity for getting news out to Tokio.

"I'm going to op that station," he said.

I wonder if anyone understood the conflict that was in the boy's heart when he went out this way to do his duty as he saw it? On the ship there was safety, while ashore there was vandalism and murder and danger. And horror! I myself saw a pile of ten thousand burning bodies; there was no time for burial. There were dangers other than being attacked by the bandits that roamed the fallen city, too. The water was polluted with typhus. Dead bodies filled the creeks. Then too, on the ship was the girl with whom Sweetheart had fallen in love. If he left her, something might happen to the ship and he would never see her again, never be able to reach her side and protect her. Too, he might die ashore and never see her again. And if he left her on the ship he left her where the purser could tell more lies to her, make her hate him. He had found out the purser's dirty work, thanks to me.

Well, he went, and there were no cheers as he did his little act of heroism, either. No brass band played, he just slipped over the side and went to shore with a returning launch that had brought out a load of refugees.

I said a while ago that you couldn't rebuild a whole station in a day. Sweetheart did exactly that. About a month ago I got a letter from him in which he told me the whole story.

The station was a couple of miles out of town, and with the town utterly demoralized there was no way to get to it. He found an automobile that was not smashed or burned, stole it, and drove out. He ran out of gas and had to walk part of the way. He found the station a wreck. The walls were down and the place had started to burn. He stopped the fire before it reached the

set. The rest of the ops in the harbor—it is a compliment to call Sweetheart an op, though, for he has a fist like a threshing machine—hadn't thought of that, nor had any of us gone ashore to find out the truth of the report that the station was a complete ruin. That was the difference between other men and Sweetheart.

Only one mast was broken, half-way up. The guys and the fallen part were hanging all over the place. Sweetheart cut away the guys and repaired the broken wires of the antenna. But the antenna was down, and it weighed a ton. How could he get it up? The good mast was two hundred feet high. He climbed it, expecting the weakened guy wires to break at any minute, and passed the antenna cable—the one designed to hold up the aerial—through the steel braces at the top of the mast, since he had no pulley. Twenty or thirty coolies had gathered to watch the white man do fool tricks. He got a gun from the station when they refused to help him, and held it over them while they pulled on the cable. He got one end up and then climbed the broken mast and got the other end up.

The receiving set worked. He was lucky there. But the transmitter had derived its power from the city mains, and they were down. The auxiliary gas engine wouldn't work; there was no gasoline and a falling timber had smashed the carburetor. He walked back to the car he had stolen, broke out the carburetor and attached it to the motor in the station. Still no gasoline. There was none in the city; he didn't know where to get any, at least. He didn't have time to walk back to the city.

There were dozens of rickshas lying where their runners had dropped them. Sweetheart found one and paid a coolie two dollars—two weeks' wages—to take him back to town. There he broke into a store, although people were being shot for vandalism every hour, and stole a cold chisel and a sledge. He found a Ford that would run and drove about town hunting wrecked automobiles. From each one he knocked off the gas tank with his sledge, and piled them into the Ford till he had fifty gallons of gas. Then he drove out to the station and got the set working.

I nearly fainted when I heard the familiar note of that land station, that night. Hear it? You couldn't hear anything else. Sweetheart had cut away the secondary of the oscillation transformer and connected aerial and ground directly to the spark gap. A 10 KW spark, it was.

I couldn't start my own set going and congratulate him, for it would have interfered with him; he wanted the Tokio station and no others.

The Japanese use a special code, sounding a lot like our numerals and

METERS

WE REPAIR THEM
REGARDLESS OF MAKE

**Voltmeters, Ammeters,
Wattmeters**

Send Them To Our Labora y

HEINTZ AND KAUFMAN
SCIENTIFIC INC. APPARATUS

219-221-223 Natoma St. San Francisco

Wonderful Bargain

at \$2.90

Here's a beautiful cabinet at a remarkable price made possible only by our tremendous production. It is quality you can't match at twice the price. The Cabinet is made of selected hardwood with three coats of lacquer, all rubbed down to a rich, lustrous piano finish. Two nickel plated hinges. No Increased Price even for Larger Sizes. A real bargain for the amateur set builder.



Piedmont

Dimensions

7" x 18" x 10" Deep
7" x 21" x 10" Deep
7" x 24" x 10" Deep
7" x 26" x 10" Deep

Your Choice at \$2.90 Ea.

f.o.b. Hickory

Cash with Order.

No C. O. D.'s

At this special price.

12 hour service
factory to you

Southern Toy Co. Inc.
Manufacturers Hickory N.C.

Tell them that you saw it in RADIO

Morse, mixed. The Japanese operator at Tokio heard Sweetheart's slow fist and had sense enough to hunt up an American operator in Tokio. I heard Tokio come back at him, finally, and whispered, as though Sweetheart could hear it, "Give 'em hell, boy."

We steamed out of port. Our captain had helped all he could, but he was under orders and had to go. I went up to the bridge and told him that the Tokio station was working and that Sweetheart had done it.

"Deserted the ship, eh?" he said. "Well, he would have been discharged for drunkenness and disregard of duty when we reached port, anyway."

So I told him the whole story, and the captain, who was as just as he was hard, changed his mind. It was Purser Merrick who got fired, and blacklisted, and Sweetheart got a personal letter from the Old Man and from the company, too. The Old Man made his apologies right when he made 'em.

Two days out Marion came up to the shack. She believed me now. The captain had told her. I let her put on the phones and listen to Sweetheart. He was still in range—it may have been untuned, but it was ten kilowatts!

I guess it sounded like sweet music to the girl. It didn't sound like sweet music to me. Not with *his* fist! But I had listened to that tired fist for two days and two nights steadily. For fifty hours Sweetheart had stuck at the key—no sleep, no nothin'. Just work, and lots of guts. Lots!

"Can you send him a message?" Marion asked me, excitedly.

"Yes, I guess so. I can call him, anyway; the work he's doing must have let up a bit by now." I was pretty sure that Sweetheart would get a kick out of hearing the old call.

I threw the switch and let him have it, and he came back. It must have been a shock to hear us so weak. He, of course, had no way to know that we had left port.

"Had to leave port for home," I sent. "Sorri. C U L. Marion hr sez Q T C msg."

"C U L om," he spluttered at not above ten words a minute. Two sleepless nights hadn't added to the beauty of Sweetheart's fist. "Hooray! GA."

So Marion dictated her message. It must have repaid Sweetheart for his long vigil:

"I know now. You are wonderful, wonderful, wonderful. Remember I think that when we meet again. Love, Marion."

So that's Sweetheart's love affair.

Specified



for the new
**Impedance
Equalized
Receiver**
described in
this issue by
Francis Churchill

See Page 25

CEC TUBES

make any good receiver
better because of
**UNIFORM QUALITY,
STEADIER
PERFORMANCE,
LONGER LIFE.**

Ask your dealer or write us for complete data sheet giving characteristics of the complete CeCo Line.

A Type for Every Radio Need

C. E. MFG. CO., Inc.

Providence, R. I., U. S. A.

Largest Plant in the World Making Radio Tubes Exclusively.

Portable Short Wave Transmitter

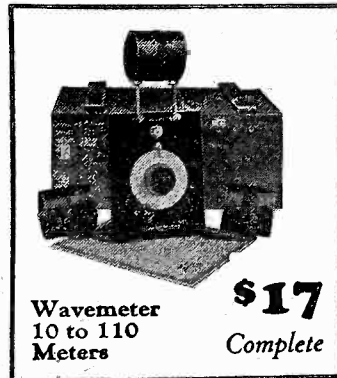

Wavemeter
10 to 110
Meters **\$17**
Complete

Complete with all accessories
including one power supply

\$90.00

We are glad to quote prices on
complete amateur and commercial
installations

Crystal Control a Specialty

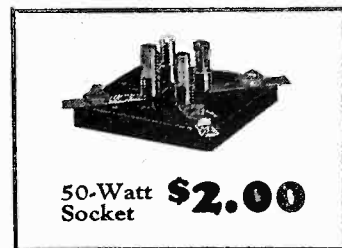

50-Watt
Socket **\$2.00**

TRANSMITTING EQUIPMENT LABORATORIES
3675 Moneta Avenue Los Angeles, Calif.

Tell them that you saw it in RADIO

FROST-RADIO

Parts for the
INFRADYNE

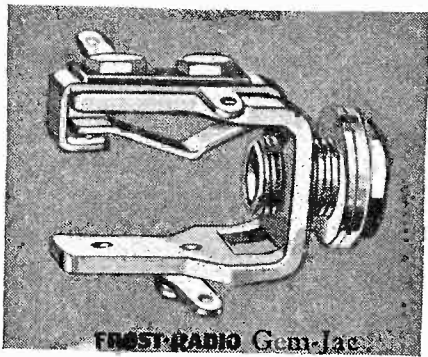

No. 954 Gem-Jac

This jack projects only 1 inch back of panel. It is the sturdiest and at the same time the most compact jack made. Brass frame is nickel plated and hand buffed. Has nickel silver contact springs with sterling silver contacts and finest Bakelite insulation. Use No. 954 in your Infradyne. List 45c.

HERBERT H. FROST, INC.
160 North La Salle Street, Chicago
NEW YORK LOS ANGELES

FROST-RADIO

Parts for the
INFRADYNE

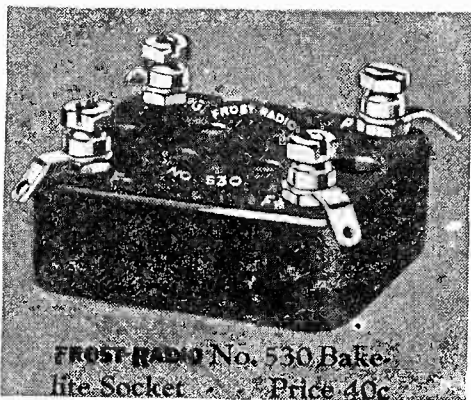

No. 530 Socket

No other socket made has such positive self-cleaning contacts as this No. 530 Frost-Radio Bakelite Socket. Tube prongs are gripped for almost entire length by heavy contact springs of special phosphor bronze. Supplied with binding posts, as shown, or in special sub-base type for sub-panel mounting, with mounting screws. List 40c.

HERBERT H. FROST, INC.
160 North La Salle Street, Chicago
NEW YORK LOS ANGELES

PHASE RELATIONS

(Continued from page 22)

portion. The right angle component of the current will assume greater values, and the in-phase component correspondingly smaller values. The stability will therefore decrease with an increase in frequency. There will be one frequency at which the in-phase component of i_4 equals i_3 . Then the circuit will be just as if the first two tubes alone were on the common impedance. The amplification is decreased by Z . But as the frequency increases, i_3 will become much greater than the in-phase component of i_4 , and the four tube circuit will in effect become a three tube resistance coupled amplifier, which is inherently unstable as was shown above.

How the stability in a four tube circuit is lost in this manner is made clear with an illustration. In Fig. 4 OA is

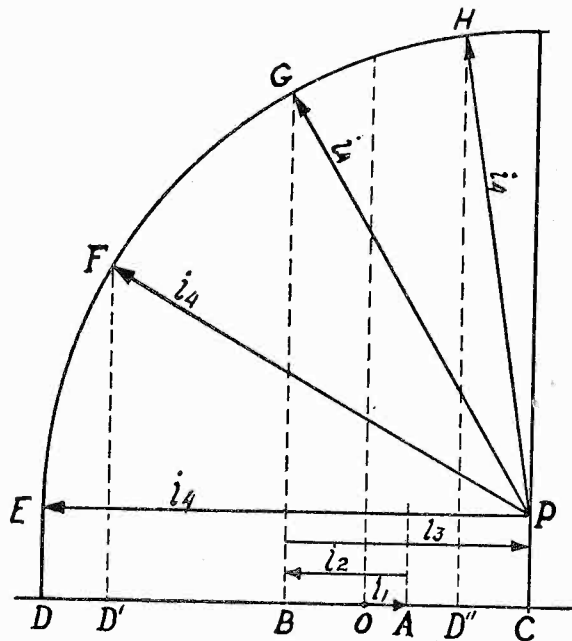

Fig. 4. Effect of Phase Relation on Stability

i_1 , the current in the plate circuit of the first tube. AB is i_2 , the current in the second tube. OB is the net current in the common impedance Z . It is in opposite phase to OA and therefore it decreases the amplification. BC is the current in the third tube. It is in phase with i_1 but opposed to i_2 . The net current through Z is now OC , which is in phase with i_1 and therefore aids the amplification. CD is i_4 , the plate current in the last tube, when this is all in phase with the emf. OD is now the net current in Z . It is opposed to i_1 and reduces the amplification.

If there is inductive reactance in the last load, i_4 lags behind the emf. At some frequency the angle of lag will be FPE . The in-phase component of i_4 is CD' for that retardation and OD' is the net current in Z in opposite phase with i_1 . The decrease in the amplification is therefore less than it was before.

For a higher frequency the angle of lag will be GPE , when the in-phase component of i_4 will be CB , that is, exactly equal to i_3 , but in the opposite direction. The net in-phase current in Z is OB , the same as it was when only two tubes were used. There is still a decrease in the amplification because OB is opposed to OA .

For a still higher frequency the angle of lag will be HPE , and the in-phase component of i_4 will be CD'' . The net current in Z is now OD'' , which is in phase with i_1 or OA , and therefore the amplification is increased. The increase begins as soon as the in-phase component of i_4 is less than CO . Oscillation is probable at some frequency above this point; but if the regeneration through Z is not sufficient for oscillation, there will be an amplification peak at the frequency where oscillation is most probable, and this peak will cause blasting and distortion. In many circuits of this type the blasting occurs in the soprano range.

An impedance coupled circuit may be analyzed in the same way although the work is not so simple. Not only is there a lag of current in every plate circuit, but there is also a phase shift in the grid input voltages. However, if all the stages are exactly the same, there is no essential difference in the result, nor in the analysis. The graphical representation would be the same as Fig. 4 except that the base line DC and the entire construction would be tilted. A circuit of an odd number of plate circuits on the common impedance would still be unstable on the low frequencies and one of an even number would be unstable at the higher.

A transformer coupled amplifier can be analyzed likewise. The analysis is quite simple if it can be assumed that the transformer ratios are constant and independent of the alternating plate currents. But there is an additional com-

Magnet Wire and Windings

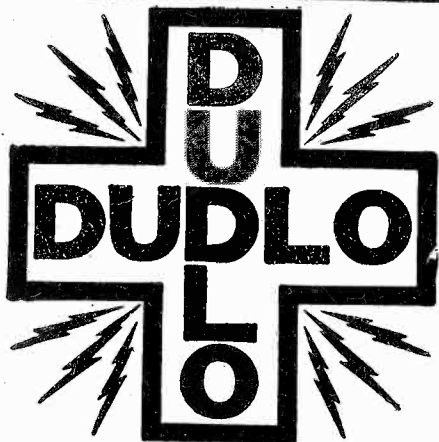
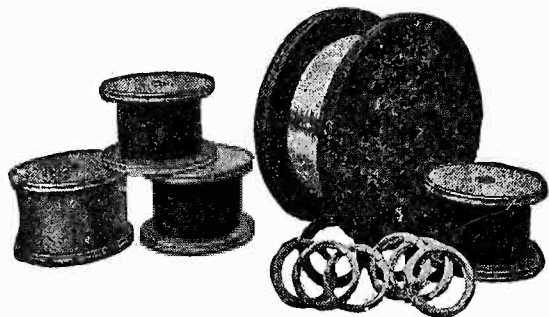

Western Representative
A. S. LINDSTROM CO.

324 N. San Pedro St.
Los Angeles

274 Brannan St.
San Francisco

95 Connecticut St.
Seattle

221 S. W. Temple
Salt Lake City

146 1/2 N. 10th St.
Portland

DUDLO MANUFACTURING CORPORATION FT. WAYNE, IND.

Tell them that you saw it in RADIO

plication introduced by the fact that a transformer can be connected in two ways. In one connection the transformer changes the phase by 180 degrees and in the other the phase remains the same. In the first a two tube circuit is relatively stable and in the second it is unstable. When there are more than two tubes in the circuit it is always possible to select the connections of the transformers so that all the plate currents are in phase, or nearly so, in the common impedance. This means stability, but at a considerable decrease in the amplification when the resistance in the common impedance is high. It is well known that a howl in a transformer coupled amplifier can sometimes be stopped by reversing a pair of leads on a transformer, and that sometimes this operation merely changes the pitch of the howl. It is when all the transformers are connected so that they change the phase by 180 degrees that greatest stability can be expected, at least at low frequencies.

Most trouble from low frequency oscillation is encountered in resistance coupled amplifiers. The reason for this is that such circuits amplify the low notes well. Almost as much trouble is met in the best transformer and impedance coupled circuits, because they, too, amplify the low notes well. Poor transformer and impedance coupled circuits rarely develop low frequency oscillation, because they do not amplify low notes. High amplification, of course, is the first requisite for oscillation. At high frequencies the common impedance, which is the means of regeneration, can be reduced by putting a large condenser across the plate voltage source; at low frequencies this is of little avail.

THE DUO

(Continued from page 29)

After checking the wiring and making a special precautionary circuit test as explained by G. M. Best in April, 1927 RADIO on page 18, the tubes, source of power, and external connections can be made preparatory to the adjustment of the receiver. As high *B* voltage as obtainable should be used on the Van Horne tube because of its "High μ " the plate impedance is high, but is brought to lower values, as in any case, by a high plate voltage. The circuit was developed using an eliminator supplying 300 volts. However, 150 volts of *B* battery gave satisfactory operation by actual test. The detector *B* voltage is best 45 volts or less for distance reception and 67 for regular operation. The *C* battery should be 1.5 to 2 volts, but not more, because of the characteristics of the double-grid tube.

When the set is operating properly the volume control will produce a whistle if turned to the right beyond a certain position. A station of medium wavelength should be tuned in, and the

Phasatrol and grid leak adjusted until best reception is obtained. The Phasatrol will generally give the proper balancing when turned nearly all the way counter-clockwise, the position of maximum neutralization. A leak of 2 megohms appears best for general operation, while a value of 3 or 4 megohms gives slightly better results on distance reception. "Motor boating" of the detector tube on strong signals can be prevented by the use of a low value, 2 megs. or under.

The operational characteristics are very similar to the Browning-Drake receiver, the station being tuned in by reducing the heterodyne beat note to zero, i. e., finding the "hollow" between the two regenerative whistles accompanying it on each side.

It will be found that the two dial readings on the drum will be almost identical. Therefore, in searching for stations they are rotated together with the same readings opposite and are followed up by the volume control. After one is located a more precise adjustment of each dial and adjustment of the volume control will give maximum volume.

The Duo is gratifyingly selective as compared with the general run of sets and no difficulty should be experienced in cutting through local stations for distance with the average broadcast antenna. In the early summer, even before the Radio Commission's reassignment of frequencies, it was possible to cut out San Francisco Bay stations, located from two to ten miles away, and bring in Los Angeles and Portland stations on the loudspeaker. In the event that greater selectivity is desired than that afforded by the Unitune as furnished, it is suggested that 3 to 5 turns be removed from coil L_3 . It was found experimentally that in some cases this reduction of the number of turns on the coupling coil to the detector circuit also aided signal strength and smoothness of operation.

Due to the few tubes used there is little possibility of overloading the loudspeaker, as can occur with six and eight tube sets. Rather, the loudspeaker for the Duo should be chosen which has been designed to give maximum response for a given input, instead of freedom from chattering at heavy inputs. In order to determine which speaker best met this requirement six representative makes were tested, with the result that a Thorola model 4 horn type proved the best. For those who desire the fullness of quality afforded by the use of both cone and horn type speaker in series a Thorola cone is recommended in addition. These recommendations are in no wise to be construed as proving the other speakers worthless, but simply indicate that the Thorola speakers measured up best to the requirements of the Duo.



Approved Power Supply Parts

An enthusiastic market demands sets powered from the light socket. Dongan, producing parts exclusively, offers to the set manufacturer power supply transformers and chokes designed for all electrically-operated sets. Dongan Power Supply Parts represent the latest development in design and refinement in construction.

Receiver manufacturers can rely on Dongan as a source of supply on Power Supply Parts for all approved types, mounted or unmounted. Send your Specifications to our engineering department. Samples available now.

Power Supply Transformers



used with

350 - 400 m.a. tubes. This transformer is constructed in a handsome, durable metal case.

\$15 list

Power Supply Chokes

for

350 - 400 m.a. tubes. Two chokes built into one case.

\$15 list

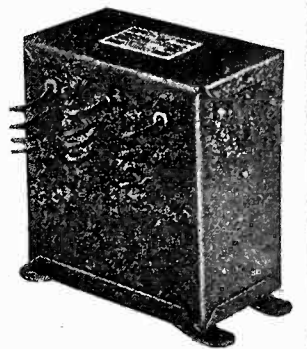

FANS—Rebuild that old set. In the long run it will be an economy and you'll have assurance of full-powered reception all the time—at a very low cost.

If your dealer cannot supply you, immediate delivery will be made upon receipt of check or money order. Specify type of rectifier you intend to use.

DONGAN ELECTRIC MFG. CO.
2991 - 3001 Franklin Street, Detroit, Michigan

TRANSFORMERS OF MERIT for FIFTEEN YEARS

Tell them that you saw it in RADIO

TELEVOCAL Quality Tubes

Better
—by Far!

COMBINE delicate detection with high amplification. Non-microphonic and cannot short because of exclusive TELEVOCAL SUPPORT and method of construction. Tested, balanced and proved perfect before leaving factory. Insist on Televocal—they cost no more! Televocal Tubes are made in all standard types.

If your dealer cannot supply you write us, sending his name.

TELEVOCAL CORP.

Televocal Building
586 — 12th Street
WEST NEW YORK, N. J.



TIME AND WEATHER SCHEDULES FOR GREAT LAKES By Fred Wagner (Late "KDXL" SS Manual)

E.S.T.	CALL	LOCATION	WAVE	WEATHER FORECAST
8:45 A.M.	WLC	Rogers, Michigan.....	715	Existing WX for Lake Huron
10:30 A.M.	WAV	Detroit, Michigan.....	1600*	Upper and Lower Lakes (Private)
10:40 A.M.	VBG	Toronto, Ontario.....	1600	Upper Lakes and Georgian Bay
10:45 A.M.	NAJ	Great Lakes, Illinois.....	2300*	Upper and Lower Lakes
10:45 A.M.	WLC	Rogers City, Michigan.....	715	Upper and Lower Lakes
11:00 A.M.	WAM	Buffalo, New York.....	715	Lower Lakes
11:00 A.M.	WTK	Cleveland, Ohio.....	715	Upper and Lower Lakes
11:00 A.M.	WME	Duluth, Minnesota.....	715	Upper Lakes
11:00 A.M.	VBC	Midland, Ontario.....	1600	Lower Lakes and Georgian Bay
11:05 A.M.	VBD	Point Tobermory, Ontario.....	1600	Lower Lakes and Georgian Bay
11:10 A.M.	VBE	Point Edward, Ontario.....	1600	Lower Lakes and Georgian Bay
11:20 A.M.	VBB	Soo, Ontario.....	1600	Lower Lakes and Georgian Bay
11:30 A.M.	VBA	Fort William, Ontario.....	1600	Lower Lakes and Georgian Bay
11:55 A.M.	NAA	Washington, D. C.....	2650	Time Signals
11:55 A.M.	NAJ	Great Lakes, Illinois.....	2300*	Time Signals
11:55 A.M.	NSS	Annapolis, Md.....	16,900	Time Signals
Noon	WGO	South Chicago, Illinois.....	890	Upper and Lower Lakes
4:00 P.M.	WAM	Buffalo, New York.....	715	Lower Lakes
4:00 P.M.	WTK	Cleveland, Ohio.....	715	Upper and Lower Lakes
4:45 P.M.	WLC	Rogers City, Michigan.....	715	Existing WX for Lake Huron
5:00 P.M.	WGO	South Chicago, Ill.....	890	Upper and Lower Lakes
5:00 P.M.	WME	Duluth, Minnesota.....	715	Upper Lakes
5:00 P.M.	NAJ	Great Lakes, Illinois.....	2300*	Hydro
8:45 P.M.	WLC	Rogers City, Michigan.....	715	Existing WX for Lake Huron
9:55 P.M.	NAA	Washington, D. C.....	2650	Time Signals
9:55 P.M.	NAJ	Great Lakes, Illinois.....	2300*	Time Signals
9:55 P.M.	NSS	Annapolis, Md.....	16,900	Time Signals
10:00 P.M.	WGO	South Chicago, Illinois.....	890	Upper and Lower Lakes
10:00 P.M.	WAM	Buffalo, New York.....	715	Lower Lakes
10:00 P.M.	WTK	Cleveland, Ohio.....	715	Upper and Lower Lakes
10:30 P.M.	WLC	Rogers City, Michigan.....	715	Upper and Lower Lakes
10:40 P.M.	VBG	Toronto, Ontario.....	1600	Lower Lakes and Georgian Bay
11:00 P.M.	NAJ	Great Lakes, Illinois.....	2300*	Upper and Lower Lakes
11:00 P.M.	VBC	Midland, Ontario.....	1600	Lower Lakes and Georgian Bay
11:05 P.M.	VBD	Point Tobermory, Ontario.....	1600	Lower Lakes and Georgian Bay
11:10 P.M.	VBE	Point Edward, Ontario.....	1600	Lower Lakes and Georgian Bay
11:20 P.M.	VBB	Soo, Ontario.....	1600	Lower Lakes and Georgian Bay
11:30 P.M.	VBA	Fort William, Ontario.....	1600	Lower Lakes and Georgian Bay

*Approximate Wave.

NOTE: WHQ sends weather at 11:15 A.M. during tourist season only on 875. WHQ Machinac Island, Michigan

TIME, PRESS AND WEATHER SCHEDULES, U. S. A. By Fred Wagner

E.S.T.	CALL	WAVE	LOCATION	
7:00 A.M.	WAX	5553	Miami, Florida.....	Press (Private)
10:00 A.M.	NAT	2700	New Orleans, Louisiana.....	Weather
10:50 A.M.	NAA	2650	Washington, D. C.....	Weather, Hydro
11:30 A.M.	WNU	3331	New Orleans, Louisiana.....	WX, TFC, Private Press
11:55 A.M.	NAA	2650	Washington, D. C.....	Time, TFC, Hydro
11:55 A.M.	NSS	16,900	Annapolis, Maryland.....	Time
1:00 P.M.	NBA	7000	Balboa, Canal Zone.....	Time
9:55 P.M.	NAA	2650	Washington, D. C.....	Time
9:55 P.M.	NSS	16,900	Annapolis, Maryland.....	Time
10:00 P.M.	VBT	2660	Montreal, Canada.....	Press (Private)
10:45 P.M.	WSH	2400	New York, N. Y.....	Press
10:50 P.M.	NAA	2650	Washington, D. C.....	Weather
10:50 P.M.	NPG	11,000	San Francisco, Cal.....	Weather
11:30 P.M.	WNU	3331	New Orleans, Louisiana.....	WX, TFC, Private Press
12:00 P.M.	NAY	5000	Brownsville, Texas.....	Hydro, Weather
12:15 A.M.	WII	13,500	New Brunswick, N. J.....	Press (Private)
1:30 A.M.	WSA	650	New York, N. Y.....	Press (Spark)
2:00 A.M.	NAA	2650	Washington, D. C.....	Navy Press
3:00 A.M.	KPH	2300	San Francisco, Cal.....	Press
4:00 A.M.	VAE	1600	British Columbia, Canada.....	Press
5:00 A.M.	NBA	7000	Balboa, Canal Zone.....	WX, Navy Press
5:00 A.M.	NPL	11,000	San Diego, Cal.....	Navy Press

SOME RECENT QST's

(Continued from page 32)

From WNU, May 31, 1927. All ships and stations: Effective June 1st, Telo, Honduras, radio call letters UC, will collect observers' messages from ships on 2100 and 2400 meters from 6 AM to 6:30 AM and 6 PM to 6:30 PM, 90th meridian time. Telo will transmit on 2400 meters. This traffic will move to New Orleans WNU at 6:45 AM and 6:30 PM.

From WNU, June 2, 1927. All ships and stations: Effective June 1st, radio station Swan Island call letters US will broadcast local morning weather at 7:30 AM, 90th meridian time on 600 meters spark.

QUERIES AND REPLIES

Have a 9 tube Superheterodyne using most of the parts specified for the 1925 Best Superheterodyne. Can these parts be used in the 1927 model, especially the intermediate frequency transformers and variable condensers?—A. E. P., San Leandro, Calif.

You can use practically all these parts

in the new circuit. It will be necessary for you to install a third tuning condenser, making a total of three dials, since the Remler condensers are not well adapted to a link motion of the type required in the 1927 circuit.

Am interested in converting my old style, three dial Neutrodyne into an Infradyne. Will there be an interaction between the open field coils used in my set, and the Infradyne amplifier? Will it in any way affect the operation of the Infradyne unit to change the filament wiring so that two of the amplifier tubes are in series so as to use 6 volts without a rheostat? Is it advisable or necessary to shield the oscillator coil?—W. R. V., Dearborn, Mich.

There will be no appreciable interaction between the Infradyne unit and the tuned r.f. part of your set. I would not advise rewiring the unit. To do so will be to void the guarantee of the manufacturer, and to unbalance the wiring in the unit to such an extent that it would be inoperative. The oscillator coil need not be shielded.



STANDARD
CLAROSTAT.
Universal
range. Carry-
ing capacity,
20 watts.
List \$2.25

CLAROSTAT

To an even greater extent than in past seasons, CLAROSTAT, the greatest variable resistor, will be identified with the leaders—in receivers, in B eliminators, in power amplifiers and in A, B, C units.

Write for complete information

American Mechanical Labs., Inc.
285 N. Sixth St., Brooklyn, N. Y.



POWER
CLAROSTAT
Universal
range. Carrying
capacity, 40 watts.
List \$3.50

LETTERS FROM LARRY

By JACK BRONT

Nr 281 Check \$8.76 Radio SS Lake Dis-comfort, Fld Date
George Hassenpeffer, 218 River Street, Hoboken.

Dear old brass masseuse (stop) Well OM we sure had a good trip this time (stop) We was working on the transmitter yesterday and I could have been done sooner only Honk likes to help (stop) Honk I says just touch one of them two wires old chop (stop) Sure he says (stop) Do you feel anything Honk I says (stop) No he says (stop) Well I says don't touch the other one then Honk because its got 18000 volts on it OM (stop) Oh migosh Honk says (stop)

Well the British post office didnt answer my letter where I explained my system for cutting down power waste and accelerating programs (stop) I hear the P O is going to take over broadcasting (stop) I showed them where they could save 7 3/4 per cent power and speed up programs KO if they made sure all the station artists dropped their haitches (stop) But I guess they think its a haitch of an idea (stop)

Well we just got to the dock this A M when Mr Bakersfield from the assassinated px was down and he says hello Sparks is there anything newsy this time (stop) Yeah I says Mr B there is I noticed a most peculiar phenomenon this time I says (stop) A bevy of passengers stood around the ship bulletin board aghast—I guess thats the way they stood anyway one gentleman was bowlegged at least—and gazed avidly at some news which you send us Mr B (stop) I cant explain it Mr B except that the third must have actually copied some press I says (stop) Aw fix your gridleak and stop the squawk the third says (stop)

Say a delayed letter from Vic Marshall with the French Foreign Legion says they had a portable super with them in Maroc (stop) I bet they pick up some hot stuff on the Sahara (stop) Vic says Boyd Nixon crawled up on a Riff encampement and located a loudspeaker on a wire and routed two hun-

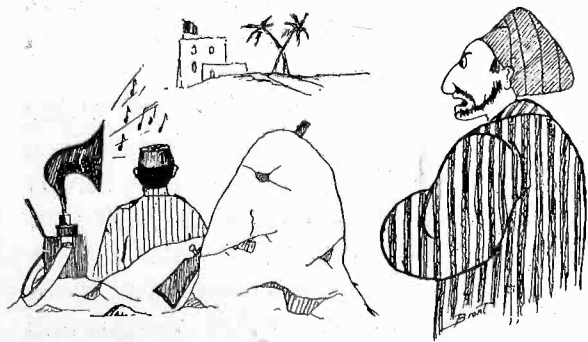

dred Riffians (stop) They fled in terror (stop) Well I done the same thing right here in those united states (stop) I mean flee in terror from a loudspeaker (stop) It was a old one (stop) But

TIME
to think about
your set!

AUTUMN is coming—World's Series games, Davis Cup matches, football, even a heavyweight championship to be decided.

But will your set be ready? Most sets lose their vitality through summer idleness, taking on a general fatigue which affects batteries, tubes and circuits alike. Your set is probably no exception.

It may have a "swinging open-circuit," improper voltage "balance" between B and C batteries, or some other electrical defect. Can you locate these troubles and correct them?

YOUR SET DESERVES AN ELECTRICAL INSPECTION WITH



WESTON
Model 519
RADIO
SET
TESTER

1000
ohms
per
volt

CONSULT A RELIABLE DEALER — one who maintains a service department equipped to make the required tests at your home. Make certain that his service man employs the instrument shown above. You can then be assured that your set will receive a thorough "conditioning" —circuits adjusted, tubes and batteries replaced where necessary —and all with laboratory accuracy.

Then with your set in complete order you should install a small Weston instrument to maintain the efficiency of your set.

There are several models available. Your dealer will advise you which one to use for your set, or write to the nearest address below and ask for Circular J.

Graybar Electric Company, Inc.
84 Marion St., Seattle, Wash.

J. H. Southard, San Francisco, Cal.

A. A. Barbera, Los Angeles, Cal.

Repair Service Laboratory
682 Mission St., San Francisco, Cal.

WESTON ELECTRICAL INSTRUMENT CORPORATION
156 Weston Ave., Newark, N. J.



Tell them that you saw it in RADIO

Most
Powerful
"B"
Eliminator

**Majestic
Super
"B"**

COMPLETE
WITH TUBE

LIST PRICE
\$29.50

See us at the
Radio Exposition in San Francisco
August 20 to 27th

Grigsby-Grunow-Hinds Co.
4580 ARMITAGE AVENUE
CHICAGO, ILL.
W. J. SEROY, Pacific Coast Sales Mgr.
122 Broadway, Oakland, Calif.

Build Sets!
make \$100⁰⁰-a week

WRITE NOW FOR FREE DATA

Get into the radio business. Let us show you how to make spare time money—easily and surely. **COMPLETE SYSTEM** No obligations. Get our system now—today. A post card brings full details.

Dept. "R"
Radio Constructors Corp., 357-12th St., Oakland

NEW RADIO LOG - 25c

All the New Listings right up to date
"RADIO" - Pacific Building - San Francisco

X, P, Q, R, M, Z, T, !

An announcement on the average loud speaker, may sound like this; but with the "ENSCO" 3 foot cone or roll speaker you hear every word and every note through the heaviest static.

Kit **GENUINE** Kit
\$10 **"ENSCO"** \$10

Why has "ENSCO" been endorsed by all leading magazines and the foremost newspapers? Because—it is the most highly developed big cone assembly now offered to the public, it reproduces all frequencies and greatly reduces static. The "ENSCO" unit is the only direct-drive unit for large cone speakers.

Manufactured under U. S. Patent No. 1630119; "ENSCO" Cushion Drive Patent No. 1163854; Cone Diaphragm Patent No. 1003655 and other patents pending.

Assemble the "ENSCO" speaker in less than an hour. It works on any set with any power. No filters or chokes necessary, 90 to 250 volts without protection or 500 volts with transformer. Six different types to choose from. Cones beautifully decorated and marked for assembly. Wall, pedestal or console; all fully described in illustrated instruction book.

Sold under absolute (money back) guarantee

ENGINEERS SERVICE COMPANY

25 Church Street.....New York City
73 Cornhill.....Boston
28 E. Jackson Blvd.....Chicago

Ask your dealer or mail order to nearest office. Send money order, check or cash, or we will ship C.O.D. We pay shipping charges.

Now
You can build the
kind of a radio you
have always wanted

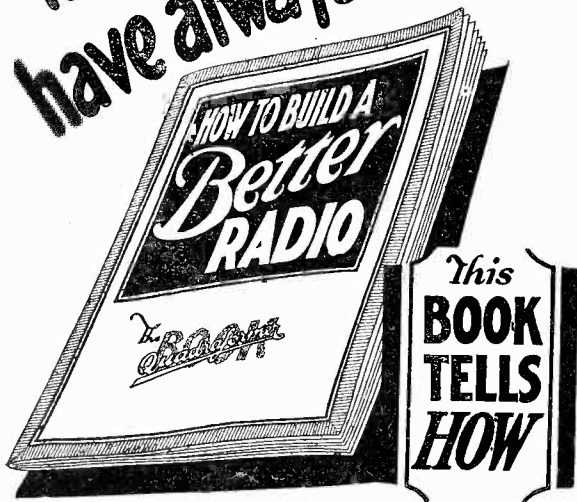

No matter whether you want to improve a set you now have or build a new one — get this book first. Tells how to build the latest one, two and three dial receivers — 5 to 7 tubes.

10¢ PREPAID

GEARHART-SCHLUETER, Fresno, Cal.

Make Any Good Receiver

CEC
TUBES

BETTER
C. E.
Mfg. Co., Inc.
Providence,
R. I.



Vic says Nixon was missing on the second and he guesses the dear Riffs know where hes at (stop) But maybe the vultures do too its sure no picnic over there with the Legionnaires (stop)

Say when we had a regular boat and fire drill Friday why some passenger come up to the shack and he says Sparks: the captain always goes down with the ship dont he (stop) Yeah I says (stop) Gee he says the captains all have gray hair (stop) Sure I says thats from getting in the salt water so much (stop) For goodness sakes he says (stop) It sure aint for the sake of vanity I says (stop)

Well Honk tuned in for Europe on long wave last night and he couldnt get a peep (stop) Say see whats wrong with this receiver will you he says (stop) Now Honk I says I know you quite a while now and I like you and everything but I sure dont approve your getting signals the way your trying I says (stop) Now Honk I says just turn them tubes on—sort of careless-like—and see if the set dont work better (stop) Well of all things says Honk (stop) Yeah I says Honk I guess they somehow just got along without tubes one time but I says when you use a regenerative receiver I says why its kind of handy to use the tubes I says (stop) Aw quit broadcasting says Honk dont you see the red light went out (stop)

Well on Tuesday a S Y T looked in the shack and she says Ooh what a nice looking radio and just as bright as anything (stop) Young lady I says I salute you as possessive of keenest perception and of most exquisite taste I says (stop) Ooh she says I er was referring to the er radio utensils you know (stop) The fleeting romantic radio waves she says (stop) Yeah I says Miss—especially about 7 P M when the evening QRM schedule starts I says (stop) Ooh she says why your work must be so romantic she says (stop) She sure do I says why Miss why only this morning I got two TRs and an impassioned QRT (stop)

Say OM I seen Hink Bolis yesterday and he says when the *Belle Horizonte* with mahogany logs for New Orleans sunk awash in the Caribbean when the life boats pulled away why Eddie Cosgrove got left behind because he stopped to change clothes OM (stop) Mr Coyne at Kingston asked how come (stop) Why I always believe in dressing for the occasion Mr. Coyne he says (stop) Why Mr Coyne says you must of thought you was going some place he says (stop) Well Eddie says when I seen the rail go under I didnt think nothing else but (stop) I heard he had on his bathing suit (stop) It wasnt a green one (stop)

We got the resistance coupled amplifier hooked up KO (stop) Honk says it ought to be good because all its got in it is pure resistance all over (stop)

Tell them that you saw it in RADIO

Honk always was gloomy-like (stop) He was born up in the Arctic where they only got two seasons night and July (stop) C U next trip old horse 73 (sig) Larry

Nr. 298, Check \$3.98 Radio, SS Lake Discomfort, Fld. Date.

George Hassenpeffer, 218 River Street, Hoboken.

Dear old horse (stop) Well OM we had a fine trip this time only on Wednesday it was kind of sad (stop) We passed some whalers and it sure is sad to see a whale blubber (stop)

Well an S Y T come along the deck and she says Ooh are you the radio (stop) No I says lady—Honk and I just works here (stop) And isnt there one other operator too she says (stop) No I says lady theres two other operators two—and I says Honk here is a part of the sad news (stop) Oh hes such a just exotic figure dont you think she says (stop) Well I dont know lady I says I think he had the measles one time—thats what makes him look that way I says OM (stop) You must just



get an awfully large salary in radio dont you she says (stop) Far from the horrible truth lady I says—I pays the company for the job so I can collect the autographed message blanks (stop)

Just then a man come along and he says have you got the butter and egg quotations (stop) No mister I says them night clubs dont ever broadcast nothing I says (stop)

I heard a Jap sending yesterday (stop) I guess he had rheumatism (stop) He didnt repeat anything (stop)

Say its long past Armistice Day now but I was thinking about Armistice Day in 1918 (stop) Just after we heard about the armistice which would end the madhouse in France—getting the dope from FL up at Eiffel Tower—the night before—Why the tar paper shack where I had the radio set was in the zone of the 77 fire (stop) The shack was blown apart next morning before the last round at 11 A M—the wind

was sure strong that morning OM (stop) Well after the shack got on fire why it set off an infantry fireworks dump behind the shack and since the Major was celebrating the end of the war by taking a bath in a big iron cook pot out in the field—why the Major was embarrassed when two big army skyrockets landed in the pot (stop) The Major was in the cook pot at the same time (stop) My ears never have been very sensitive since I heard the Majors comment (stop) General Sherman never had active skyrockets in his bath tub OM—at least when he was in the bath tub too (stop)

Say OM if you heard a certain California station shut down real sudden one night a couple of months ago you might of wondered what was wrong (stop) Well it was this way (stop) An old timer who had been General Sherman's personal operator resurrected an old comrade in arms from the Soldiers home and had him describe the dramatic surrender of the beloved Lee to our General Grant O M(stop) Well the old veteran wasnt much on grammar and construction—not nothing like I am OM—but he took the two bits in his teeth and started off KO until he got to the worst (stop) Quote yes you see folks me and Grant was standing there waiting for Lee you see folks and Lee comes up and he says hello Grant and Grant says hello there Lee (stop) Well then folks Lee says Grant take this dad burned sword of mine will yuh (stop) Aw gwan Grant says—Lee I dont want your doggoned old sword (stop) Yuh better keep it for the plowing in the spring—now let me see folks—No I guess it was to keep the horses for the plowing folks—but anyway folks Grant turns around and he says is that all right Bill (stop) Sure I says Grant thats all right with me and then me and Grant went home folks—thats all I guess folks—but I aint sure folks whether it was to keep the sword or the horses—unquote (stop) Happily the mike had been disconnected early in the discourse—and the tired old veteran slipped softly down on the studio floor (stop) He never got back to the Old Soldiers Home OM (stop)

Well OM how is your skip receiver coming along (stop) Last night I was out on deck some time after 11 px and something hit me just amid ships (stop) I aint sure about what it was but I think these skippers ought to do something about it (stop)

Well OM this is about all this time as I got to write up three weeks log (stop) Im sure behind with the log OM as I only got it wrote three months ahead (stop) Watch out for that guy that signs off K all the time (stop) He ought to be reported for not using his whole call (stop) 73 old horse

(sig) Larry



Mr. Set Owner:—

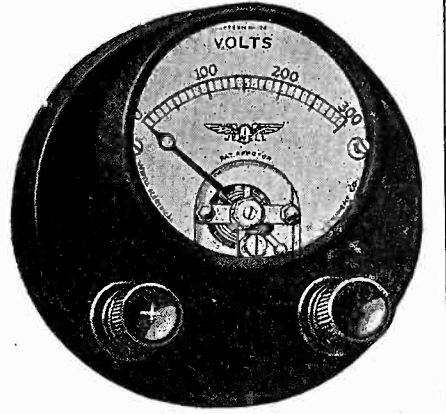

Pattern No. 139

You are now able to obtain a high resistance voltmeter to check the voltages of your B-eliminator and at a price that is well within the limits of your pocket book.

The Jewell Pattern No. 139 B-Eliminator voltmeter was produced with the set owners requirements in mind. It is three inches in diameter and of the same permanent magnet, moving coil, D'Arsonval type movement as are the larger types of high resistance meter. Its 0-300 volt scale enables readings to be taken of all ordinary eliminator voltages. The resistance is sufficient to guard against excessive lowering of the circuit voltage when using the instrument.

Ask your dealer to show you this instrument or write us direct for descriptive circular No. 1103

Jewell Electrical Instrument Company

1650 WALNUT STREET, CHICAGO

"27 Years Making Good Instruments"

Metal Cans for the new ABC Eliminator

Sheet steel cans, with steel baseplate, exactly as specified by G. M. Best in this issue, shipped direct from the factory. Cans are of best grade 20 gauge steel, riveted at all joints, and finished in handsome baked enamel. Baseplate has flanged edges, so that wires can be run underneath. Ventilating holes in sides and lid provide adequate protection against overheating of parts. Ideal for any type of ABC eliminator, and absolutely fireproof.

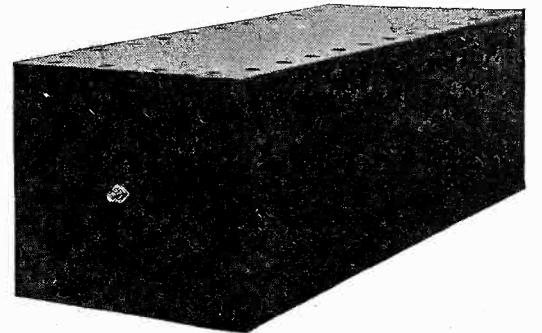

Price \$5.00, f.o.b. factory at Oakland

WESTERN TRANSFORMER COMPANY

618 EAST 11th STREET

OAKLAND, CALIF.



Ward Leonard Vitrohm Resistors

Rated to carry 60 watts continuous duty.

1100 ohms with taps of 400, 400 and 300 ohms.
2600 ohms. 7000 ohms.

Your choice of any of these three sizes at
EXTRA SPECIAL PRICE OF
85 CENTS EACH

All of these Ward Leonard Heavy Duty, Vitrohm (vitreous enamel) Resistors are brand new, Size 4x1 in. They are absolutely permanent and accurate in value and are for use in your Eliminator, Transmitter and all kinds of electrical control work.

AMERICAN SALES CO., 21 WARREN STREET, NEW YORK CITY

Tell them that you saw it in RADIO

Why Paper and Why Mica in Radio Condensers?

By Harry F. Houck

Chief Engineer, Dubilier Condenser Corporation

The reasons for using mica as the dielectric in certain condensers and paper for others, are governed by many factors passed upon by the engineering as well as the production staff of the condenser manufacturing establishment. What is more, there are certain economic considerations which decide the dielectric that shall be employed. So well are these various factors defined that the mica condenser has a clearly delineated field of uses, while the paper condenser, likewise, has another clearly defined field.

First of all, mica is the better dielectric. It has far greater electrical strength than paper, which is to say that for a given mass of material, it will withstand greater voltages without breakdown. At the usual operating voltages in radio reception, a mica condenser should have virtually a perpetual life, while the carefully built paper condenser should have a life of from ten to fifteen years in contrast with the poorly built paper condenser with an indefinite lease of life which may be measured in hours or days or weeks or months.

However, mica cannot be worked as thin as paper, which is the main drawback to its employment in large capacity condensers. Mica cannot be worked to thickness less than a 2 mils, while paper, on the other hand, can be worked to 0.5 and even 0.4 mils. Hence the mica condenser, with its considerably thicker dielectric, must have larger plates and more of them to equal the capacity of the paper condenser with its much thinner dielectric. The mica condenser will be much bulkier, therefore, for voltage ratings below 1,000, but at 1,000 volts and above the properly built paper condenser must have six layers of paper for the dielectric, which causes the paper condenser to be almost as large as the mica condenser. Above 1,000 volts, obviously, the mica condenser comes into its own more and more as the voltage increases, since the marked plurality of papers necessary in the corresponding paper condenser soon makes the latter impractical.

In the matter of cost, the mica condenser is virtually prohibitive for large capacities at 1,000 volts or less. The manufacture of the mica condenser is far costlier than is the case with the corresponding paper condenser. Each piece of mica must be individually tested. Then the assembly calls for the stacking of alternate sheets of mica and tinfoil, one by one. By way of contrast, the paper condenser starts out with paper and tinfoil in rolls, which

have been passed upon beforehand. The assembly is purely a matter of winding the interlarded tinfoil and paper into a compact roll, on automatic machines.

The discrepancy in production cost between mica and paper is reflected in the final price of the respective condensers. Thus taking a 1 mfd., 1000-volt condenser as the basis for comparison, the paper condenser will cost in the neighborhood of \$5, while the mica condenser will cost about \$25. Translating these figures into terms of radio power unit practice, in which at least 10 mfd. is required for an ideal B-eliminator, it will be noted that the comparison shows \$50, for the paper and \$250 for the mica.

From the technical standpoint, there is a clean-cut distinction between the proper sphere of the mica condenser and that of the paper condenser. The former, aside from its necessary application to radio transmission, is essential in the radio-frequency end of reception, where radio-frequency energy is being handled. Mica has the necessary permanency of capacity, low phase angle, and ideal power factor. Paper does not make for such precise, highly efficient performance. Hence the growing tendency of late on the part of some to substitute tinypaper condensers for the usual mica condensers or micadons in the radio-frequency end of reception is to be deplored. Grave losses in efficiency are bound to result, and variation in capacity is almost certain to alter the critical balance of the radio-frequency circuit. Even on the plea of economy, which can be the only excuse for the use of small paper condensers, the diminutive paper condensers cannot justify themselves for the reason that in the corresponding mica condenser the small quantity of materials together with the relatively simple assembly for the small capacity condenser provides little differential in cost between paper and mica.

In the audio-frequency end, however, where low-frequency currents are handled and where the capacities run very much greater, the paper condenser is altogether justified while the mica condenser would be economically unsound, as well as entirely unnecessary. The only advantage that could possibly be gained through the use of mica would be virtually indestructible condensers of endless life. However, as the result of long experience we have learned how to make paper condensers which, used at their rated voltage, have a life well in excess of ten years—or a radio lifetime.



For continuous duty at
20, 40, 100 and 200 watts



Aerovox Products are Specified
by
Gerald M. Best

AEROVOX

"Built Better"

PYROHM RESISTORS

AEROVOX Pyrohm Resistances are made of the best grade of resistance wire, wound on a refractory tube and coated with a porcelain enamel which thoroughly covers and protects the wire from moisture, oxidation and mechanical injury. All Resistance Values. Tapped Resistances for all popular circuits in stock.

AEROVOX WIRELESS CORP.

70 Washington St., Brooklyn, N. Y.

Build Sets make \$100.00 a week

GET INTO RADIO GAME

Let us show you how to make money in your spare time building Infradyne receivers. The sale of one set with accessories nets you a substantial profit. The new 1928 Model DX Infradyne will be the season's winner.

PROFITABLE, FASCINATING WORK. START NOW!

Get going now—let us send you complete circulars outlining our entire system. Anybody with ordinary mechanical ability can profit from this new method.

THE SEASON HAS OPENED

August 1st is the opening date of the new radio season. Long distance reception will be good this year. You can make Infradyne demonstrations now and outperform any set on the market.

GET OUR PLAN NOW

The plan is ready for you—now. A post card will bring complete details. Be the first man in your town to get into the INFRADYNE business. Don't delay!

RADIO CONSTRUCTORS CORPORATION

Dept. "R," 357 12th St., Oakland, Cal.

Tell them that you saw it in RADIO

COPPER SHIELDING FOR RADIO

By COPPER AND BRASS RESEARCH ASSOCIATION

WHEN an electric current runs through a wire, magnetic lines of force are set up about the wire creating what is known as a magnetic field. If the wire is wound into a coil, the magnetic field is increased and if iron is inserted into the coil, the field is still further increased. This field is not confined to the center of the coil or the iron core but spreads out around the coil in the form of magnetic flux in accordance with the shape of the coil. In coils of the solenoid type, the field is most intense along the axis of the coil but flux lines spread outside the coil from its ends. The toroidal or doughnut type coil, which is a solenoid bent in the form of a ring, is designed to confine these stray flux lines as the coil has no free ends. The binocular type of coil has approximately the same characteristics. These special coils, however, together with basket-weave and spider-web type all have fields extending outside the coils to some distance.

It will be seen then that if these coils are inserted in a radio receiver and are not spaced sufficiently far apart, the free fields will interlink so that the radio-frequency currents in one coil will set up interfering currents in another coil, producing what is known as feed-back or radio-frequency inter-stage coupling. This manifests itself in the form of whistles in the loud speaker attached to the set when the radio-frequency circuits are brought into resonance by means of the dials on the tuning condensers. There is another form of feed-back due to electro-static coupling between the grid and plate elements of the tubes. This coupling, in most radio-frequency receivers, is neutralized by means of small feed-back condensers called "neutrons." This method of neutralizing was invented by Prof. Hazeltine and is known as the neutrodyne principle.

Electro-magnetic shielding is employed to screen these stray coil fields from the adjacent tuning transformers and confine these fields to their respective stages of radio-frequency amplification. This is known as inter-stage shielding. In addition there is another type of shielding employed in a few receivers to prevent the inductances of the set being affected by the fields from waves of super-power stations in the direct vicinity of the receiver. This type of shielding is essential in congested localities where there are a great number of broadcasting stations, and consists of surrounding the complete receiver by a metal lined cabinet so that waves radiated by the stations can enter the receiver only by way of the aerial connection.

There is a Vitrohm Radio Resistor

for EVERY power unit

More than 90 standard Vitrohm Resistors and Rheostats cover the resistance need of every socket power circuit now on the market.

Resistance is the heart of power circuits. Make sure of quiet, permanent, and unfailing service by insisting on Vitrohms for radio.

Vitrohm Resistors and Rheostats are guaranteed unconditionally for continuous-duty in any circuit where they operate within their watts dissipation rating—Vitrohm Resistors have the highest continuous-duty rating without resistance change of any resistor.

New Vitrohms

The list below of new resistors and rheostats is partial. A full description of new Vitrohms for Radio is available without charge. Send for it.

RAYTHEON 350 M. A. UNITS
Vitrohm Resistor 507-70 \$8.75
Vitrohm Rheostat 507-59 5.50

QRS 400 M. A. CIRCUITS
Vitrohm Resistor 507-62 \$8.75
Vitrohm Rheostat 507-59 5.50

SILVER-MARSHALL UNITS
Vitrohm Resistor S-M 653 \$2.50
Vitrohm Resistor S-M 655 2.50
Vitrohm Resistor S-M 657 5.00

THORDARSON POWER PACKS
Vitrohm Resistor for R-171 \$2.15
Vitrohm Resistor for R-210 2.65
Vitrohm Resistor for R-210 4.90
with UX874 Regulator Tube

The Adjustat

A new Vitrohm Rheostat, dissipating 20 watts, having 15 steps of resistance. The Adjustat is priced at \$3.00.

11 types are available in the following resistances and current capacities:

507-79, 1 ohm, 4 amp.—507-71, 2 ohms, 3 amp.—507-72, 6 ohms, 1.5 amp.—507-73, 20 ohms, 1.0 amp.—507-74, 30 ohms, 0.75 amp.—507-80, 50 ohms, 650 m.a.—507-81, 600 ohms, 180 m.a.—507-75, 1000 ohms, 125 m.a.—507-76, 2250 ohms, 90 m.a.—507-77, 10,000 ohms, 40 m.a.—507-78, 25,000 ohms, 10 m. a.



WARD LEONARD
ELECTRIC COMPANY
MOUNT VERNON, N. Y.

Tell them that you saw it in RADIO

POWERIZER

AGAIN LEADS THE FIELD!

THOSE who heard the new POWERIZER operating on a Radiola 20 direct from the light socket with the new AC tubes at the R.M.A. Show held recently in Chicago, expressed genuine amazement at the marvelous tone and unusually fine performance. They were thoroughly convinced that POWERIZER again leads the field.

There is only one solution to the ABC supply problem. That is raw AC current stepped down and fed direct to tube filaments with a POWERIZER.

Model PXY-1

Gives ABC power supply and the marvelous POWERIZER tone to any set. Uses no batteries, liquids, or paste. Made complete in a compact, beautifully finished container. Can be connected in a short time. Uses 216-B as rectifier and 210 as amplifier. There are taps to handle filaments of UY-227 and UX-226 tubes.

Model PXY-2

Gives the power supply deluxe which means power supply to detector tube and all tubes ahead of it. Can be operated from phonograph or electric receiving set. This POWERIZER amplifies and enriches the tone of any phonograph and electric receiving set. Far beyond anything you have ever heard.

Jobbers and Dealers

Write us TODAY for folder 1009-RR. "Real ABC Socket Power with Real Tone." It contains much information that will keep YOU off the rocks this year and make money for YOU!

Licensed by Radio Corporation of America and Associated Companies

RADIO RECEPTOR Co., Inc.
106 SEVENTH AVE., NEW YORK

MODERNIZE YOUR RADIO

YAXLEY

IMPROVED RADIO PRODUCTS

Improvements will bring you a new standard of convenience and comfort in radio entertainment.

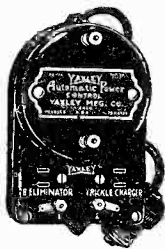

Automatic Power Control

Switches on the B eliminator and cuts out trickle charger when set is turned on and

the reverse when the set is turned off.

No. 444—Series Type Automatic Power Control—Now furnished in the new construction, exclusively Yaxley, to take care of sets having a current draw from four 199 type of tubes up to eleven 201 type of tubes, keeping the voltage drop below 2/10 volts.....\$5.00

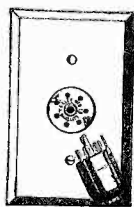

Convenience Outlets

To give you greater joy with your radio, with less muss and fuss with its accessories, these Radio Convenience Outlets permit the wiring of the home so that batteries are out of sight, a loud speaker can be placed in any room, and with the aerial and ground can be tapped like your regular electric convenience outlets. Do away with unsightly lead in wires and set connections. Avoid damage to the building and acid stains on floors or furnishings. Outlet plates made single or in gangs. Fit any standard switch box or may be attached directly to plaster laths or studding.

No. 135—For Loud Speaker and Head Phones.....\$1.00

No. 136—For Aerial and Ground 1.00

No. 137—With Plug for Battery Connections 2.50

Write for new illustrated and descriptive price list.

At your dealer's. If he cannot supply you, send his name with your order to

Direct Representatives:

Henger-Seltzer Co.
1111 Wall Street, Los Angeles
377 Brannan Street, San Francisco

Don H. Burcham
1553 E. Everett Street, Portland

In the present-day receivers of the better type, both forms of shielding are employed by enclosing the inductances with their associated apparatus in individual copper cans to comprise a completely shielded and individual radio-frequency amplification unit.

Practical Shielding

ELECTRO-MAGNETIC shielding to be effective must be complete. The smallest crack or opening is sufficient to spoil the whole receiver and it is imperative, therefore, that great pains be taken with the work and that plenty of time be allowed for the process. The problem is not one for a beginner in radio. It should be undertaken by those experimenters only who have had some experience in building sets and who are acquainted at least with typical commercial broadcast receiver circuits. It should be borne in mind that shielding is not purely a mechanical operation as it requires technical design as well, based on the action of the radio-frequency circuits in the set. The design of the receiver that is to be shielded must be thoroughly studied, electrically as well as mechanically, before satisfactory results may be obtained.

It is especially difficult to shield receivers already designed and built without shielding and the most satisfactory and practical method is to tear down and rebuild the receiver with shielding as the basis of the new design. In many five-tube receivers, for instance, the radio-frequency tubes are not placed directly behind their inductances and condensers. Instead they are placed beside the condenser-inductance unit and are staggered with the audio-frequency tubes. For this reason it is difficult to make a can to surround the condenser-inductance and associated tube of each radio-frequency stage. It is better to redesign the set with the radio-frequency tubes directly behind their respective inductances (which as a rule are mounted on the condenser frames) and build rectangular cans to hold the complete units.

The ideal theoretical shielded receiver is one in which the inductances are so widely spaced that their fields cannot interlink. Because of size limitations and feed-back due to wiring, etc., this condition is impracticable, if not impossible, and it is therefore necessary to sacrifice efficiency slightly for practicability by using a shielding material that will dissipate these stray fields in the form of small eddy current losses. As the efficiency of this dissipation is proportional to the conductivity of the shielding material, copper is found to be the most practicable material for the purpose.

In laying out the design of the shielded receiver, the size of the can for the radio-frequency unit must be considered first. This is determined by the

equipment it is to hold,—the condenser, inductances and tubes being the essential factors. The most important of these is the inductance, which must have sufficient clearance to the walls of the can. In general, it is best to make these cans just as large as possible while taking into consideration that large radio-frequency units require correspondingly larger main and sub-panels to hold them.

After the radio-frequency unit cans have been designed, make up a layout plan of the set to scale. Design the sub-panel to set 1/16 in. behind the main panel and locate the center can on the center line of the set, laying out the rheostats, volume control, jacks and mounting brackets. Allow room enough between the cans for rheostats and volume control that are usually mounted on the main panel and design these to be mounted on the panel between the cans. It is not necessary that these be shielded provided the wires go directly into the shielded box below the sub-panel, or into one of the inter-stage cans directly adjacent to the controls. As a rule, the set will wire best if the jacks are mounted on the panel below the sub-panel so that they project into the sub-panel box.

This layout will determine the length of the main panel and sub-panel. Now lay out the audio tubes and transformers to determine the depth of the sub-panel and make a front view of the set and cans to determine the necessary main panel height. If it is found that the panel will be too long rearrange the jacks to be located directly under the rheostat and volume control and, if necessary, decrease the width of the cans a little to gain space.

Make a schematic diagram and from it work out a full scale working wiring diagram, rearranging the parts to make the leads as short and direct as possible. The negatives of both *A* and *B* batteries may be soldered directly to the cans thus saving a lot of wiring. This shielding should be connected to the ground binding post of the set. Plan on insulating the parts, etc., where necessary, with bushings or blocks of hard rubber.

The most practical shielding material will be found to be 16 oz. soft copper sheet, which may be procured from any tinsmith, plumber or hardware dealer as it is a standard size which is invariably carried in stock. It is best to use sheet that has not been coiled to keep the surfaces as flat and true as possible.

A receiving or transmitting tube that will not oscillate any more can be made to serve as a rectifier tube as long as the plate or grid are not shorted to the filament. The socket springs connecting to the grid and plate of the tube should be wired together, so that the tube will carry more current.

Tell them that you saw it in RADIO

They

stand the surges

PARVOLT WOUND CONDENSERS

Are specified most frequently in circuits where service is hard and only a good condenser can stand up.

Use the proper Parvolt Wound Condensers in the filter circuits of current supply units and know that all condenser problems are completely eliminated.

Parvolt Wound Condensers are made for three maximum service voltages:

Type A— 400 V. d. c. con. duty
Type B— 800 " " " "
Type C—1000 " " " "

THEY STAND THE SURGES

Made and guaranteed by
ACME WIRE COMPANY
NEW HAVEN, CONNECTICUT

SARGENT'S INFRADYNE MANUAL

Describing Last Season's MODEL

Is now ready for
Immediate Delivery

Order your copy now
by sending 25c in coin or
stamps to

"RADIO"

433 Pacific Bldg., San Francisco



TREGO

Phonographs
PORTABLE

Greatest Value In Portables Today

FINE FOR

MOTOR TRIPS,
BOAT RIDES,
DANCING
OFFICE and the HOME

\$10⁵⁰



NELLIE TREGO
Designer of the famous Trego Portable.
DEALERS and AGENTS WANTED
Men here is your lifetime opportunity selling America's finest portable phonographs from our own big, honorable factory. Easy to sell, lowest factory prices. Big steady demand in every locality.

\$200 TO \$500 A WEEK
No experience necessary. We show you how and furnish everything you need. Your success is assured with a steady income every month. Every customer satisfied—or we refund his money for you—big repeat business. Be our factory agent in your locality. Failure impossible.

WRITE FOR DEALERS' CATALOG
Write today for our big free 32 page catalog showing our lowest wholesale prices, nothing like it in the country today. Factory direct to dealer—no middle man profits—let us be your warehouse and carry your stock for you.

EXCLUSIVE AGENCY GIVEN IF DESIRED
Manufacturers of the new Trego light socket, no battery radio with built in speaker, \$100.00. Console built in speaker \$175.00. Hear and see them at your dealer. If your dealer cannot supply you, write us direct and we will appoint an agent or dealer in your locality.

Trego Radio Mfg. Co.

1427 Chestnut

K. C. Mo.

FREE SAMPLE OFFER
We are making a daring offer to dealers and agents who want to make big money. We will send a sample to any one who wants to test it and if you do not say it is the best portable on the market we will gladly refund your money plus 50c for your trouble. Trego Radio Mfg. Co., wants dealers in every locality. Mail the coupon below.

TREGO RADIO MFG. CO.
1427 Chestnut K. C. Mo.
Please send your free 32-
page catalogue and
proposition to

The SHELBURNE

"DIRECTLY FACING THE SEA"
ATLANTIC CITY

"European Plan"

Famous French Grill and Restaurant

"A rendezvous for those who seek
the best"

MUSIC
SHELBURNE CONCERT ORCHESTRA
Proprietary-Management,
JACOB WEIKEL

Tell them that you saw it in RADIO

Most from Your Tubes

GOOD tubes are little better than poor tubes without Amperite. Utmost performance and longest life requires the perfect automatic filament control of each individual tube, afforded only by Amperite. Insist on this variable filament resistance—and look for the name. Eliminates hand rheostats. Simplifies wiring.

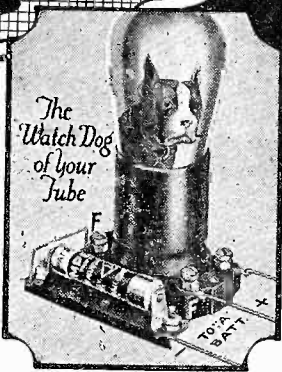

Radial Book—FREE

Explains fully Amperite principle and operation. Gives season's best Hook-Ups and Construction Data. Send for it today to Dept. R-9

Radial Co., 50 Franklin St., New York



Price \$1.10 mounted (U.S.A.) Sold Everywhere

AMPERITE

REG. U.S. PAT. OFF.

The "SELF-ADJUSTING" Rheostat

SOUND EXPERT ADVICE

On Radio and Scientific Patents

Specializing in Radio Patents and Trade Marks and Investigations Relating Thereto

John Flam, Patent Attorney

821 Merchants National Bank Building
Los Angeles California

BEST'S SHIELDED

SUPER BLUE PRINTS \$1.00

"Radio" San Francisco

LYNCH RESISTORS

ARTHUR H. LYNCH, Inc.

1775 Broadway General Motors Bldg. New York City

IMPEDANCE EQUALIZED RECEIVER

(Continued from page 27)

edge of the winding is about $\frac{1}{8}$ in. above the end of the secondary coil for a preliminary setting. This coupling can be varied after the set is completed and the proper adjustments are being determined.

The second stage tuning condenser and the detector tuning condenser are coupled together by means of a $\frac{1}{4}$ in. brass rod 10 in. long. These condensers have removable shafts so that several of them can be run from one shaft if desired. The rotors can be lined up properly after the set is in operation by tuning to some broadcast station around 300 meters and moving the rotors of these two condensers with the fingers until the loudest signal results. As soon as this position is found, the set-screws in the rotors should be tightened. It was found that the two condensers were exactly in line in the set described after this adjustment had been made.

It should be noted that the Amperite filament resistances are wired in the negative side of the first 3 tubes so that a negative bias of 1 volt is obtained on each of these tubes. Either plus 45 or 67 $\frac{1}{2}$ volts should be used on the two stages of r. f. and 90 volts on the detector. The $\frac{1}{4}$ megohm resistance in the plate circuit of the detector, drops the voltage down so that a 1 volt negative bias here is just right for bias detection when using a high mu detector.

The volume control is in the grid circuit of the first audio amplifier tube, being one of the new variable high resistance units combined with a filament switch. This means that the filaments are shut off when the volume control knob is all the way around to the minimum side of the potentiometer. The audio amplifier was designed for use with a type 171 power tube in the last stage so an output choke is used to protect the loudspeaker windings. If any audio howling or singing is present in the completed receiver, grounding the cases of the two audio transformers and the output choke will generally cure it.

In building this set, the detector can

be a low mu tube using a grid condenser and leak and the first stage of audio frequency can be eliminated. The volume control potentiometer should in that case be placed across the secondary of the first audio transformer. However the arrangement as used in this receiver is preferable.

After the set has been completed and the wiring all checked, the batteries, aerial, ground, and loudspeaker should be connected in and the tubes inserted, 201-A type in the two r. f. stages and first two audio stages, a high mu tube in the detector socket and a 171 power tube in the last audio stage. The phase control condensers C_1 and C_2 and also the two condensers C_3 and C_4 , should be set at minimum capacity by unscrewing the adjusting screws on the Variocondensers. C_1 and C_2 should then be brought up in capacity until the receiver just oscillates when the tuning condensers are nearly all of the way out, or when the set is tuned to a short wave station.

It will be noted that the receiver will not oscillate on the upper wavelengths which is a common fault with tuned r. f. receivers. This effect is overcome by adjusting the condensers C_3 and C_4 until the receiver just oscillates over the whole broadcast band. It may be necessary to adjust the primary coupling somewhat while making these adjustments. Changing one condenser or transformer coupling affects the other adjustments so quite a bit of juggling is necessary in order to make the receiver just barely oscillate over the whole tuning range of the receiver. After these adjustments have been made, C_1 and C_2 should be reduced slightly so that the receiver does not oscillate and it is then ready for operation.

In adjusting the various constants of this circuit it will be found that certain settings will cause it to oscillate over a certain band or up on the higher wavelengths and so forth. When the receiver shown in the picture was set up in its final form, it took about ten minutes to make all of the necessary adjustments, which shows that there is nothing complicated about them.

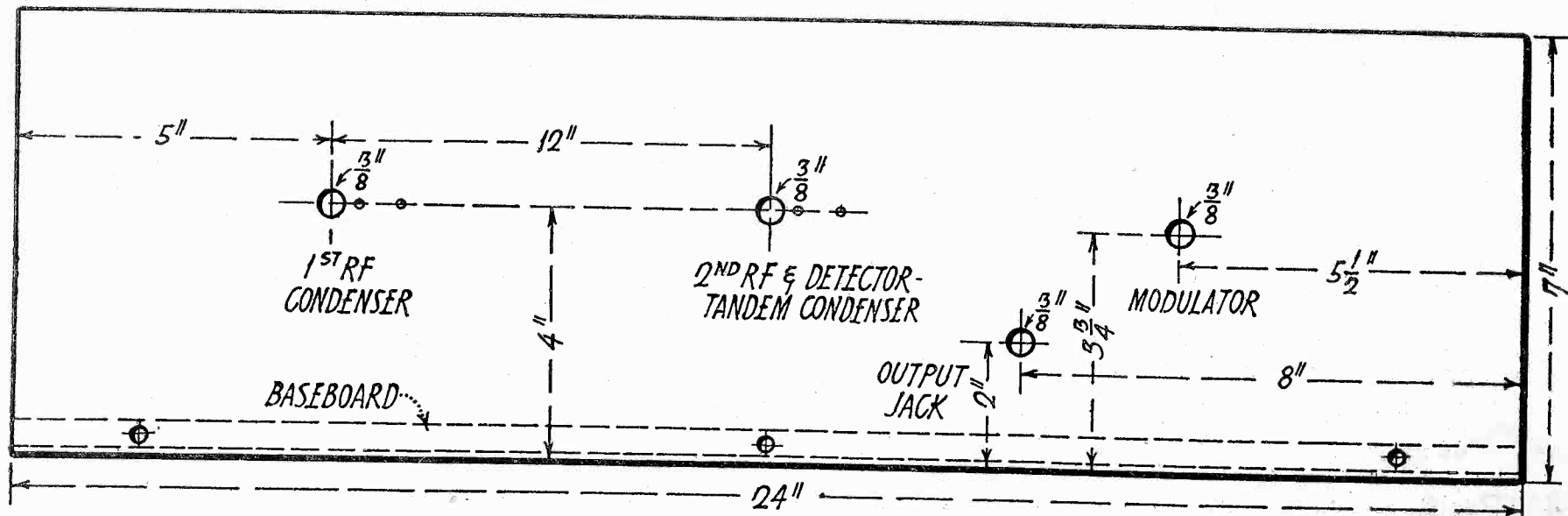

Fig. 6. Panel Layout

Tell them that you saw it in RADIO



PERFECT

**Tube Performance
demands *AMPERITE***

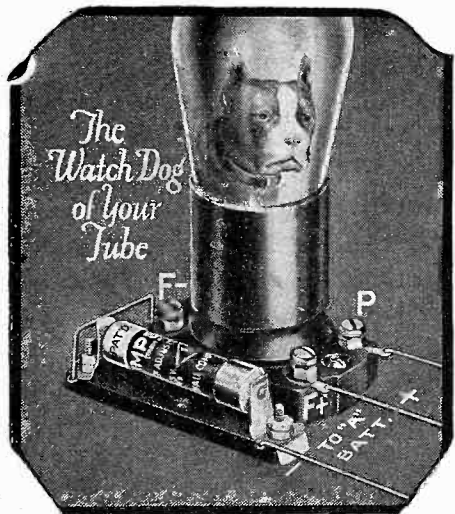

FREE — Write for
"The Radiall Book"
containing the latest popular
Hook-Ups and Construction
Data, to Dept. K-7

NO tube is better than its filament regulation. And Amperite alone guarantees that perfect regulation required to bring the utmost in clarity, volume and tone quality out of your tubes.

With Amperite you can forget both tubes and rheostats. At all times—under every varying battery condition—this variable tube filament current resistance works automatically, eliminating hand rheostats and rendering

every tube fool-proof against damage and premature burn-outs. If you want Amperite performance — insist upon Amperite. Don't be misled into buying substitutes represented as just as good. There is only one Amperite — and nothing else will do. Approved and specified by leading engineers in every popular circuit.

Types for every tube and battery. Sold everywhere. Price complete with mounting \$1.10 (in U. S. A.)

Radiall Company

52 FRANKLIN STREET, NEW YORK

AMPERITE
REG. U.S. PAT. OFF.

The "SELF-ADJUSTING" Rheostat

Tell them that you saw it in RADIO

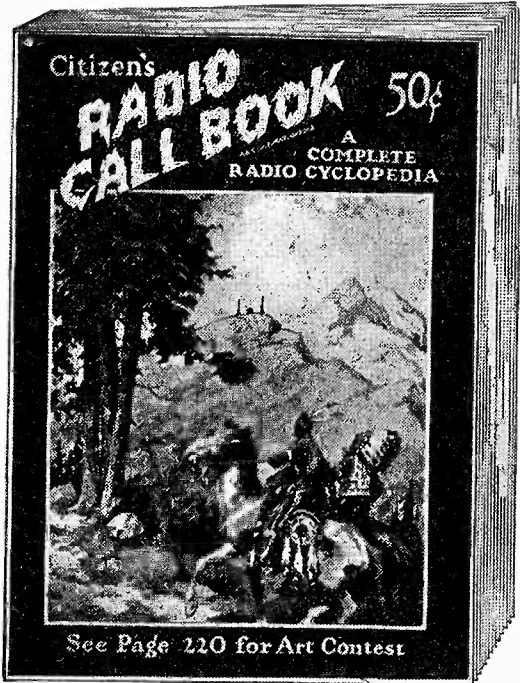

RADIO'S GREATEST Publication

The March issue of the **CITIZENS RADIO CALL BOOK** is now available.

This issue contains a wealth of live radio information, including a complete and up-to-date list of all broadcasting stations in the world, showing schedules, wavelengths, etc.; a wonderful picture section of 150 radio celebrities, a new department known as Ampere Andy's Assistors, giving the latest shop hints, showing illustrations how to maintain and repair your receiver.

SEVENTEEN FEATURE ARTICLES

This section is known throughout the entire radio world as having the most complete construction information available. Every receiver has been designed and thoroughly tested in our laboratories. The illustrations and accompanying drawings have been very carefully prepared by a staff of trained editors, radio engineers and radio draftsmen. Here you will find your favorite circuit so simply described that any novice can easily construct by following these specifications.

The **CITIZENS RADIO CALL BOOK** is published four times yearly, January 1st, March 1st, September 1st, and November 1st. You may now subscribe by using the coupon below for one, two or three years and save money. By subscribing you will receive each issue by mail promptly upon date of issue.

Fill in the coupon at the bottom of this ad and mail at once.

TEAR OFF HERE

CITIZENS RADIO SERVICE BUREAU, Inc., Publishers C
508 So. Dearborn St., Chicago, Ill., U. S. A.

Date.....192.....

Please enter my subscription for the **CITIZENS RADIO CALL BOOK** for one year, \$1.75; two years, \$3.25; three years, \$4.50. Enclosed please find.....in payment for same, mailed postpaid four times yearly, January, March, September and November. Canada and Foreign \$2.00 yearly.

Name.....

Address.....

City.....

State.....

Valley Chargers

Manufactured by
VALLEY ELECTRIC CO.,
ST. LOUIS, MO.

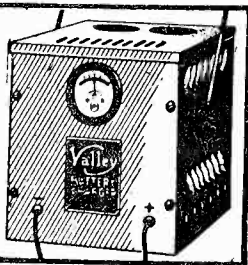

KARAS EQUAMATIC MANUAL Price 10c.

Build the Karas Equamatic 5-Tube Radio Sensation—the most selective receiver ever designed. Mail 10c today for 16-page Manual of wiring diagrams and complete instructions for building this remarkable receiver. Address:

KARAS ELECTRIC COMPANY
4031-H No. Rockwell St. Chicago, Ill.

COILS MATCHED

Radio frequency coils accurately matched for Infradynes and other sets. What a difference this makes. Only 35 cents per coil. Send them to Laboratory of "RADIO," Pacific Bldg., San Francisco. We also are in a position to purchase these coils for you.

(Continued from page 60)

All meters are mounted in the same way. The plates of either the long or short wave transmitter are supplied by a 1000 volt motor-generator set driven by the Northern Lights engines; a. c. is supplied to the filaments from a similar source. A relay is used to key the high voltage. After some experimentation, grid and plate-stopping condensers of 600 picfarads were adopted.

The antenna for the short-wave set was quite a problem because of sails, guys, etc. The two-wire antenna used for the long-wave equipment and which averages 110 ft. above the deck, was operated at a harmonic for a time, but a short vertical wire and ground was finally adopted.

All amateurs are requested to listen for KEGG on 37.5 and also on 23 meters where most of the work will probably be done, as Borden wants to keep in touch with the United States, and Chicago in particular. R. W. Hart, chief operator, will be on the air and there will be a chance for anyone to clear his hook. Listen for Hart; he's pleasant to talk to and knows his stuff. Ralph says he'll answer all cards; they had better be addressed to him at 30 Grand Ave., Oakland, Calif.

SIGNAL CORPS SUCCESS WITH SHORT WAVES

One of the most remarkable advances in radio development during the past two or three years has been the use of high frequency radio transmitters of small power for long distance communication. While some of the advantages of high frequencies had been known for a long time, the ability of high frequencies to be effective with a fair degree of reliability at great distances is a comparatively recent discovery.

The Signal Corps started experimental work on radio sets both telephone and telegraph, using high frequencies, late in the year 1917. Frequencies from 30,000 to 2,500 kilocycles (10 to 120 meters) were investigated in both transmitters and receivers. This investigation was undertaken for two main reasons: First, to overcome interference from sets using the more common wave lengths at that time which were in the band of frequencies now used for broadcasting; and second, to obtain sets which would radiate efficiently on small antennas.

The use of a small antenna being important for airplanes as a long antenna interfered with maneuvering the planes, and a small antenna was important for a small portable field set.

This experimental work resulted in the completion, during 1918, of satisfactory radio telephone sets for airplanes operating on frequencies from 4,000 to 2,600 kilocycles and of a small portable field telegraph set working on about 4,160 kilocycles.

Tell them that you saw it in RADIO

The above sets were of a few watts output and were intended for short distance work only and they proved satisfactory for the work for which they were designed.

Twenty-five models of the short wave airplane set were constructed. These sets gave satisfactory telephone communication between planes three miles apart, the maximum ranges obtained being about seven miles. The portable telegraph set with only minor modifications is one of the modern army sets for short range work of from 5 to 15 miles and additional sets of this design are now being purchased from time to time.

The ability of short waves to be effective at great distances was not discovered until several years after the above sets had been completed. In June, 1925, the Signal Corps placed an order with a commercial company for a high frequency set of 1 kw. output, capable of working on any frequency from 15,000 to 3,750 kilocycles and to be crystal controlled.

Early in 1926, the Signal Corps decided that the War Department Radio Net could handle official business with much less expense and provide quicker service if high frequency radio sets of low power were installed to supplement the low frequency sets of high power. The Navy had had considerable experience with high frequency transmitters and with crystal control for such transmitters.

The engineers of the Signal Corps conferred with the Naval Research Laboratory and due to the co-operation obtained from this laboratory, the Signal Corps was able to construct in its own laboratory 10 high frequency crystal controlled transmitters of Navy design and to have them installed during the year 1926.

Ten more transmitters of similar type but of improved design are under construction and will be installed during the present year. These transmitters are of 500 watts, rated output, and their construction has been warranted as they are used for about 75 per cent of the official messages of the War Department Radio Net at a great saving in power bills and maintenance. During the summer when static conditions are severe, these sets have proven far superior to high power low frequency sets.

Further development of high frequency sets for aircraft is being actively pursued.

VERY LATEST STATION LOG AND DIRECTORY

25c IN HANDY SIZE
PRINTED ON BOND

PACIFIC RADIO PUB. CO.
433 Pacific Building
San Francisco California

QUERIES AND REPLYs

(Continued from page 30)

to which the type 99 detector tube ordinarily used, is connected.

Have built a superhet similar to Best's 1927 model, only am using no tuned r. f. stage. There are from four to six points on the oscillator dial for each local station. The set will not work with any kind of grid condenser, and must use a $4\frac{1}{2}$ volt negative bias to make the tube detect.—O. R. W., Reidsville, N. C.

If you are using an outdoor antenna, and no tuned r. f. stage, it is not surprising that you are troubled with oscillator harmonics. The tuned r. f. stage was used to obtain the necessary added selectivity so as to permit using an outdoor antenna. There is nothing you can do to remedy the trouble other than tuning the antenna circuit, by placing a .0005 mfd. variable condenser and a 100 turn honeycomb loading coil in series, between the antenna and the antenna binding post on the set. By tuning the series condenser, the trouble from harmonics should disappear. If you are using a loop antenna, and are troubled with harmonics, your intermediates are probably not well matched, and you may be getting too much energy from your oscillator, particularly from its harmonics.

There should be no trouble from the use of a grid condenser and leak in either the first or second detectors in this model. You may have had a leaky grid condenser in the first detector circuit, which would cause trouble, the only remedy for which would be to install a C battery in place of the condenser and leak.

Have built a Gibbons ship wave receiver, as described in RADIO a number of years ago. This receiver oscillates badly on 600 meters, although it is a wonder for copying C. W. at great distances. What can be the cause of oscillation, and how may it be remedied.—A. M., San Francisco, Calif.

This famous receiver has been successful in so many cases that it is unusual to hear of trouble with it. Where the feedback is excessive, it may be due to the fact that the grid leak is shunted across the grid condenser instead of being connected directly between the grid and the filament. The latter method is the best, as it prevents placing B voltage on the grid of the tube, through the grid leak. If you will insert a midget variable condenser, say .00005 mfd. maximum, between the plate of the tube and the antenna terminal of the tuned circuit, you can control the regeneration and oscillation to suit the wavelength on which you are receiving, and in this way get rid of the oscillation trouble.

Will my old B eliminator transformer designed to give 150 volts on each side of the center tap operate a Raytheon BH tube satisfactorily?—R. A. I., Dayton, O.

You will require at least 200 volts per winding to get satisfactory current supply from the Raytheon tube, at the voltages you would probably need. You can use the entire transformer to supply a half wave rectifier tube, such as the new CX-381, and thus obtain at least 180 volts for the power tube.

Tell them that you saw it in RADIO

RADIOADS

☪ ☪ ☪

A Classified Advertising Section Read by Better Buyers.

☪ ☪ ☪

The rate per word is eight cents net. Remittance must accompany all advertisements. Include name and address when counting words.

☪ ☪ ☪

Ads for the September Issue Must Reach Us by August Fifth

BAKELITE PANELS, Tubes and Rods. Engraving and Drilling. W. A. Vetter, 24 12th St., San Francisco, Calif. (6T)

DOUGHNUT COILS Brand New—high grade coils, \$1.00, each, or \$3.00 per set of three, which includes 1 antenna coil and two tuning units. Limited number; order quickly. D. B. McGown, 435 Pacific Bldg., San Francisco, Cal.

"BEST CRYSTAL ON EARTH" — Postpaid, fifty cents each. Fully Guaranteed. Harry Grant, Jr., 904 Oak Grove Ave., Burlingame, Calif.

GET the 1927, Third Edition Revised of "Radio Theory and Operating" by Mary Texanna Loomis, member Institute of Radio Engineers. President and lecturer on Radio, Loomis Radio College of Washington, D. C. This is a thorough text and reference book of 886 pages, 700 illustrations and bound in flexible, red Kraft leather, lettered in gold. Used by practically all the radio schools in U. S. and Canada in addition to many Universities, Technical Colleges and High Schools. The standard reference book of the Department of Commerce, Radio Supervisors, and used by U. S. Naval Training Schools and Coast Guard Academy. The only radio book that is right down to date; contains much valuable matter never before published; it covers the field more thoroughly than any six radio books on the market. Price \$3.50, postage paid to any place in U. S. and Foreign countries. Get it of your book dealer. If he does not handle, send check or money order to Loomis Publishing Company, Dept. X, 405 9th St., Washington, D. C.

SET BUILDERS—Substantial discounts on parts for the new 1928 INFRADYNE are allowed to those who specialize in home-built sets. Write now for complete illustrated circulars. RADIO CONSTRUCTORS CORPORATION, 357 Twelfth St., Oakland, California.

Madison Moore 8 tube super. Brand new. With Weston double range voltmeter and Weston 0-50 M. A. milliammeter. Cardwell Condensers. Madison Moore intermediates and General Radio audios. Wired and balanced perfectly. Parts alone cost me \$110. Will sell to first person sending me money order for \$55. Set works beautifully. H. Beck, 639 Masonic Ave. (Phone Pacific 7099), San Francisco, California.

Parts for the 1928 Model DX Infradyne can be secured from the Laboratory of "RADIO." Bring last year's Infradyne up to date. Radio's Laboratory, 433 Pacific Building, San Francisco, Calif.

With a subscription to "RADIO" for one year you get a Continental Control Switch FREE. Send \$2.50 for a subscription and this handy device will be sent you on same day your subscription reaches us. Pacific Radio Pub. Co., 433 Pacific Building, San Francisco, Calif.

KENNEDY 220 Receiver also 525 Amplifier. 7-A Western Electric Power Amplifier, tubes. Perfect condition. Lot \$50.00. Roy Strong, Manteca, Calif.

Built and guaranteed short wave receivers. One tube, \$20. Two tube, \$25. Also five watt transmitters, \$30. Everything guaranteed. Write. Send draft. Raymond Campbell, Monticello, Iowa.

Sell amateur phone and key transmitters and receivers, Orville Crossland, Jefferson, Kansas.

FOR SALE: An ideal 100 watt transmitter, including starting equipment, Esco 100 volt D. C. motor generator, 4-50 watt R. C. A. tubes, 2 Kellogg microphones. This outfit was formerly WHBH and has been heard in practically all states. Equipment could also be easily converted into a high power C. W. outfit. The above will be sold as a complete unit or the sale of separate parts will be considered at a very reasonable figure.

Now! ⁹great Radio Training made greater!

If you want to get into the Radio Profession, or if you're in it and want to get ahead—

Read This Announcement!



J. E. SMITH,
President

Here's a message of importance to every man who hopes to better himself along the lines of Radio. Never before has there been a Radio training course that could be made to fit the needs of all—both experienced men who wish to better themselves and inexperienced men who wish to start from the beginning. There is one now. I am prepared to help the beginner start in Radio from the very beginning. And I am prepared to help the Radio dealer, the experienced Radio operator, the Radio service man, the college engineering student, the graduate engineer, the Radio fan, the "ham," the factory or broadcast man who wants to get a more responsible job.

An old, established system of Radio home-study training has now been developed, improved, tested, and enlarged in scope so that now it not only will help anyone who wants to get into the Radio profession, but more, can be adapted to help almost any man now engaged in Radio (Radio engineers of experience and standing excepted).

If you want to get into Radio, or if you're already in it and want to add to your knowledge and get ahead, let me send you my free 64-page book of information about this new and greater Radio training system.

The Good Jobs Pay \$50, \$75, Up To \$200 a Week — Some Pay More

If you're earning a penny less than \$50 a week, you're not earning what you should be able to get out of Radio. Thoroughly-trained Radio men—men whose knowledge of Radio is practical and completely rounded out on every point—earn up to \$200 and \$250 a week. Radio is a new industry with plenty of fine positions unfilled. There are countless opportunities in Radio for a man to earn a splendid salary. But these are not opportunities as far as you are concerned, unless you are fully qualified for them. The only way to qualify is through knowledge—training—practical, complete training that fits you to get and hold a better position in the Radio field.

For the beginner, I have a complete training that will take him from beginning to end. To the Radio dealer I'll give the technical and practical knowledge he has to have. I will round out and bring up to date the experienced Radio operator's knowledge. I can take a Radio service man who has a pretty good idea of the "how" but very little idea of the "why," and give him the practical and theoretical knowledge he must have before he can hope to climb higher on the Radio ladder. I can take the college engineering student, or the graduate engineer, who wishes to specialize in Radio, and give him what he needs.

What other line offers such an opportunity as Radio? From \$2,000,000 a year in 1920 to \$500,000,000 a year in 1926; from 1,900 persons engaged in Radio in 1920 to 300,000 in 1926. That's its record. The accomplishment of television and the many other inventions constantly being made promise the same sort of boom for the future.

If you're already in the Radio business, stay in it. But prepare yourself for advancement and more money. If you're not in Radio yet, get in. Men always do their best at work that interests them.

Send Coupon For Free 64-Page Book

My free 64-page book is filled with facts and photos relative to Radio and its opportunities, and tells all about my new and greater system of Radio training. Under my practical methods, you can study at home in your spare minutes, and get a thorough, clear, practical and expert knowledge of Radio in from 4 to 12 months. The time required depends on your previous knowledge, your ability, and the time you can spare for study. You keep right on with the job you have—no necessity for your leaving home or living on expense.

This proposition is open to anybody who is not satisfied with his job, his prospects, or his Radio knowledge. Regardless of how much you know already (or if you don't know the first thing about Radio technically) I'll fit my methods to suit your needs. No particular amount of general education is needed to start—many men I've trained didn't even finish the grade schools.

If you want to enter into any correspondence about your own situation, anything you write will come directly to me and will be held strictly confidential. Send the coupon at the right, or write me a letter today.

Address: **J. E. SMITH, President**

National Radio Institute

"Oldest and Largest Radio Home-Study School in the World"
Washington, D. C.

Employment Service to all Graduates

Originators of Radio Home Study Training

The Beginning of Radio • 1898-1902

Below is the historical Marconi apparatus. These "jiggers" are transmitters and receivers, used by Marconi in his first Radio experiments.

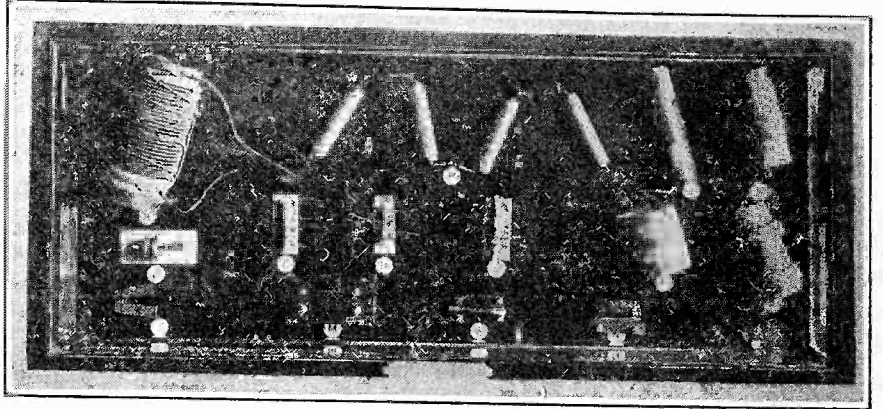

Radio Television— First Demonstration, 1927

Below, television apparatus in operation—perhaps the best indication of the enormous progress made by Radio during the past 25 years. Now we not only can transmit any sound by Radio, we have learned to SEE by Radio as well.

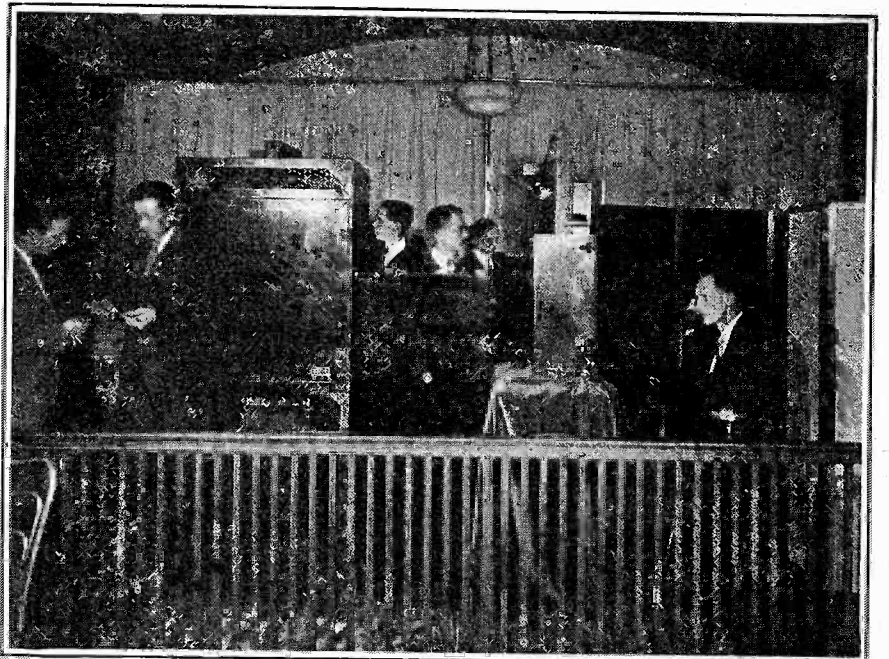

**Mail this Coupon
for free information**

J. E. SMITH, President,
National Radio Institute,
Dept. HB-5, Washington, D. C.

Dear Mr. Smith: Kindly send me your free 64-page book about your new and greater Radio training system. I understand this request places me under no obligation, and that no salesman will call on me.

Name.....

Address.....

Town..... State.....

Complete A.C. Operation A Practical Reality

For the past several seasons the trend has been toward complete battery elimination. Many satisfactory plate supply units operating from A. C. have been developed but filament operation from an A. C. source has presented more of a problem due to the larger currents required and increased expense in the rectifier and filter circuit.

The newly announced A. C. tubes offer an excellent solution to this problem.



**Type 440-A
Low Voltage Transformer**

The alternating current tubes require a source of low voltage capable of delivering large current. The various types of tubes require several different voltages. The type 440-A transformer supplies voltages for all popular A. C. tubes and sufficient current for all ordinary receiver requirements. Filament supply is provided for filament, separate heater, power amplifier and rectifier tubes. The following voltages and currents are available. Pri. 115 (for lines 105-125 volts) 60 cycles.

Sec. 2	volts.....8	amperes
	3.5 volts.....2	amperes
	5 volts.....2.5	amperes
	7.5 volts.....2	amperes
	Price \$10	

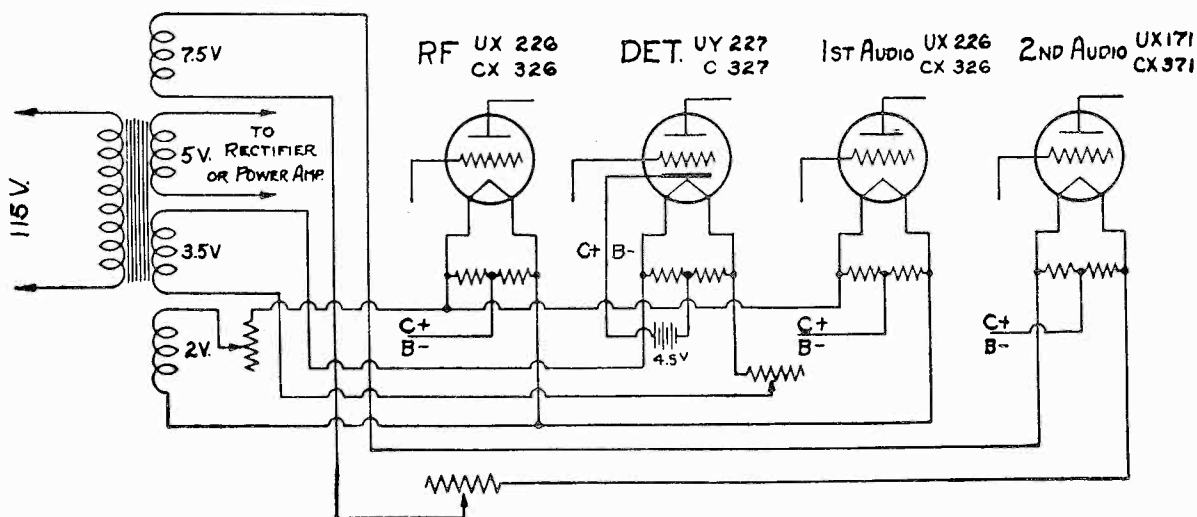

The above diagram shows how to adapt the filament wiring of the popular type of receiver to A. C. operation by use of General Radio parts especially designed for this purpose.

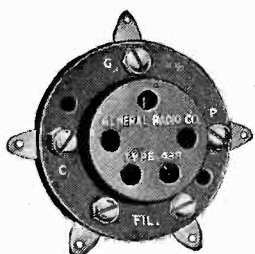

Type 438 Socket

The new type UY-227 or CX-327 detector tube has a separate heating element and requires a socket designed to take the new five prong base.

Type 438 socket.....\$0.50

The various types of A. C. amplifier tubes are designed with standard UX or CX base having four prongs.

Type 349 socket.....\$0.50

Type 439 Center Tap Resistance

All the new A. C. tubes require a resistance with center tap across the filament as shown in the diagram. The Type 439 Resistance is adaptable to any socket in which the new A. C. tubes may be used.

Type 439 Center Tap Resistance.....\$0.60

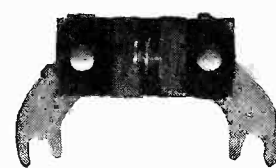

Type 410 Rheostat

The new A. C. tubes require low resistance rheostats capable of carrying appreciably more current than those used with D. C. tubes.

Resistance	Current	Price
.5 ohm	3.5 amperes	\$1.25
1.5 ohm	2.0 amperes	1.25

Your local dealer should have the necessary parts in stock. If he is unable to supply you with all the items required, we shall be glad to send them to you prepaid upon receipt of list price.

GENERAL RADIO CO., Cambridge, Mass.

GENERAL RADIO

LABORATORY EQUIPMENT

PARTS and ACCESSORIES

Presenting
a NEW
BROWNING-DRAKE
MODEL 7-A

SINGLE DIAL SEVEN TUBES
COMPLETELY SHIELDED
ILLUMINATED DRUM CONTROL
SUPER-SELECTIVITY

AFTER several years of intensive research by G. H. Browning and Dr. F. H. Drake, the laboratories of the Browning-Drake Corporation have brought to commercial form an entirely new conception of the world famous Browning-Drake receiver.

Ability to cut through the strongest local interference, and remarkable distance performance, even superior to previous accomplishments give this new receiver an unmistakable appeal, although Browning-Drake receivers have a record of seven successive nights of transcontinental reception. The first Browning-Drake to use more than five tubes, this new receiver embodies many mechanical refinements, including complete shielding and a highly efficient and novel tuning drive system.

As the culmination of nearly five years of study and progress, and backed by the reputation of the Browning-Drake Corporation, this receiver, we believe, will occupy a paramount position in radio this year. High grade dealers throughout the country are prepared to offer several models of these new Browning-Drake sets, as well as the official Browning-Drake kit for home assembly, which has won wide spread popularity.

Every fan knows Browning-Drake. Thousands own the factory built receivers. And more fans are building the official Browning-Drake kit sets than any other type of kit assembly.

DEALERS: Browning-Drake now offers a complete line of receivers and kit parts. Sales of Browning-Drake parts during the past season were more than twice those of any other. Inquiries will receive prompt attention.

BROWNING-DRAKE CORPORATION
CAMBRIDGE MASS.

BROWNING-DRAKE
RADIO

H. L. KRIEDT CO., SAN FRANCISCO, CALIF.